

T40FM

Torque flange



Characteristic features

- Nominal (rated) torque: 15 kN·m, 20 kN·m, 25 kN·m, 30 kN·m, 40 kN·m, 50 kN·m, 60 kN·m, 70 kN·m and 80 kN·m
- Nominal (rated) speed up to 8000 rpm
- Compact design
- High permissible lateral forces
- High radial and torsional stiffness
- Without bearings or sliprings
- Digital transmission of measured values
- Large measurement frequency range up to 6 kHz (-3 dB)
- Optional: Magnetic speed measuring system

Overall concept

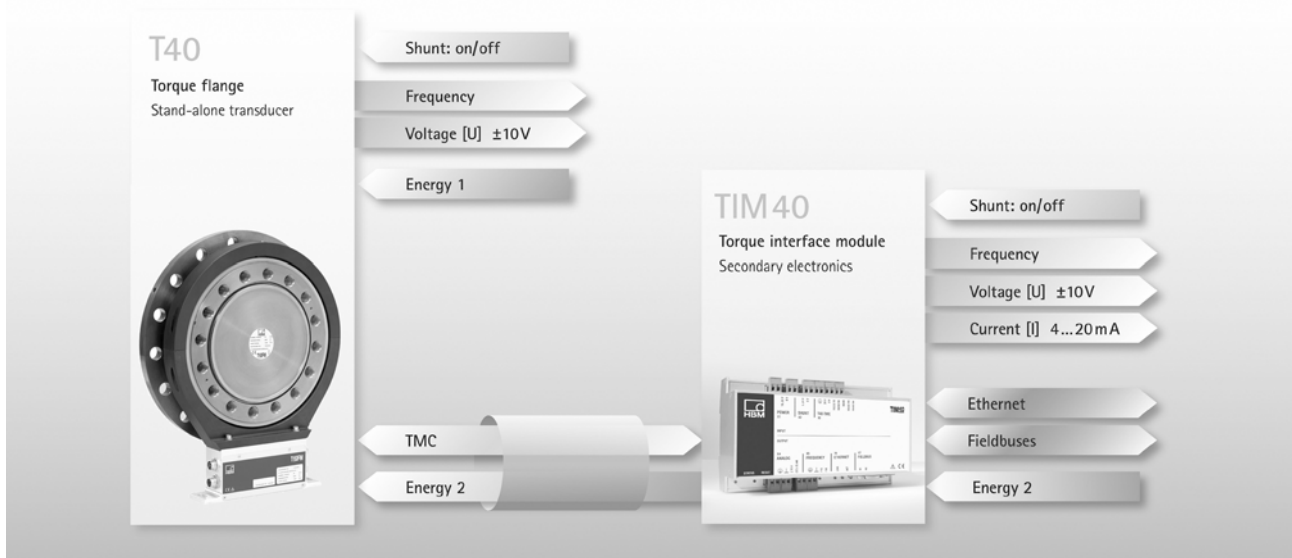

Specifications

Type		T40FM								
Accuracy class		0.1								
Nominal (rated) torque M_{nom}	kN·m	15	20	25	30	40	50	60	70	80
Nominal (rated) speed optional	rpm	6000			4000			3000		
	rpm	8000			6000			4500		
Torque measuring system, frequency output										
Nominal (rated) sensitivity (nominal (rated) signal range between torque = zero and nominal (rated) torque) Option SU2 Option DU2 Option HU2	kHz	10								
	kHz	60								
	kHz	240								
Sensitivity tolerance (deviation of the actual output frequency at M_{nom} from the nominal (rated) sensitivity)	%	± 0.2								
Linearity deviation including hysteresis, relative to the nominal (rated) sensitivity	%	< ± 0.1 (optional < ± 0.05)								
Relative standard deviation of repeatability (variability) , per DIN 1319, related to the variation of the output signal	%	< ± 0.05								
Load resistance	kΩ	> 2								
Output signal at torque zero Option SU2 Option DU2 Option HU2	kHz	10								
	kHz	60								
	kHz	240								
Nominal output signal (RS422, 5 V symmetrical) At positive nominal (rated) torque, Option SU2 At positive nominal (rated) torque, Option DU2 At positive nominal (rated) torque, Option HU2 At negative nominal (rated) torque, Option SU2 At negative nominal (rated) torque, Option DU2 At negative nominal (rated) torque, Option HU2	kHz	15								
	kHz	90								
	kHz	360								
	kHz	5								
	kHz	30								
	kHz	120								
	Maximum control range ¹⁾									
Option SU2	kHz	2.5 ... 17.5								
Option DU2	kHz	15 ... 105								
Option HU2	kHz	60 ... 420								
Maximum bandwidth (-3 dB)										
Option SU2	kHz	1								
Option DU2	kHz	3								
Option HU2	kHz	6								
Group delay										
Option SU2	μs	< 400								
Option DU2	μs	< 220								
Option HU2	μs	< 150								
Temperature effect per 10 K in the nominal (rated) temperature range										
on the output signal , related to the actual value of the signal spread		%								
on the zero signal , related to the nominal (rated) sensitivity		%								
		< ± 0.1								
		< ± 0.05								
Long-term drift over 48 h at reference temperature , related to nominal (rated) sensitivity		%								
		≤ 0.03								

¹⁾ Output signal range in which there is a repeatable correlation between torque and output signal.

Specifications (continued)

Torque measuring system, voltage output										
Nominal (rated) sensitivity (spread between torque = zero and nominal (rated) torque)	V	10								
Sensitivity tolerance (deviation of the actual output frequency at M_{nom} from the nominal (rated) sensitivity)	%	± 0.2								
Linearity deviation including hysteresis , relative to the nominal (rated) sensitivity	%	< ± 0.1								
	optional	< ± 0.05								
Relative standard deviation of repeatability (variability) , per DIN 1319, related to the variation of the output signal	%	< ± 0.05								
Output signal at torque zero	V	0								
Nominal output signal at positive nominal (rated) torque	V	10								
	at negative nominal (rated) torque	V	-10							
Maximum control range ²⁾	V	± 12								
Invalid measured value	V	13 ... 15								
Load resistance	kΩ	> 10								
Residual ripple ³⁾	mV	< 40 (peaktopeak)								
Temperature effect per 10 K in the nominal (rated) temperature range on the output signal , related to the actual value of the signal spread	%	< ± 0.2								
	on the zero signal , related to the nominal (rated) sensitivity	%	< ± 0.15							
Long-term drift over 48 h at reference temperature , related to nominal (rated) sensitivity	%	≤ 0.03								
Speed measuring system										
Nominal (rated) torque M_{nom}	kN·m	15	20	25	30	40	50	60	70	80
Measurement system		Magnetic, via AMR-sensor (Anisotropic-Resistive-Effect) and magnetized plastic ring with embedded steel ring								
Magnetic poles		158			186			204		
Maximum position deviation of the poles		± 50 angular seconds								
Output signal	V	5V symmetrical (RS 422); 2 square wave signals approx. 90° phase shifted								
Pulses per revolution		1024								
Minimum rotational speed for sufficient pulse stability	min ⁻¹	0								
Pulse tolerance ⁴⁾	Degree	< ± 0.05								
Maximum permissible output frequency	MHz	4								
Group delay	μs	< 5								
Radial nominal distance between sensor head and magnetic ring (mechanical distance)	mm	1.6								
Working distance range between sensor head and magnetic ring ⁵⁾	mm	0.4 ... 2.5								
Max. permissible axial displacement of the rotor to the stator ⁶⁾	mm	± 1.5								
Hysteresis of reversal in the case of relative vibrations between the rotor and the stator Torsional vibration of the rotor	Degree	< approx. 0.2								
	Horizontal stator vibration displacement	mm	< approx. 0.5							
Load resistance ⁷⁾	kΩ	? 2								

2) Output signal range in which there is a repeatable correlation between torque and output signal.

3) Signal frequency range 0.1 to 10 kHz.

4) At nominal conditions.

5) The pulse tolerance improves with reduced distance and vice versa.

6) The data refers only to a central axial alignment. Deviations lead to a change in pulse tolerance.

7) Note the termination resistances as per RS422.

Specifications (continued)

Application limitations											
Reference temperature	°C	+20									
Nominal (rated) temperature range	°C	+10 ... +70									
Operating temperature range ⁸⁾	°C	-20 ... +85									
Storage temperature range	°C	-40 ... +85									
Permissible ambient humidity Relative humidity / no condensation	%	5 ... 95									
Load limits ⁹⁾											
Nominal (rated) torque M_{nom}	kN·m	15	20	25	30	40	50	60	70	80	
Limit torque	kN·m	32			60			110			
Max. limit load of measuring body ¹⁰⁾	kN·m	100			200			350			
Breaking torque (static)	kN·m	>100			>200			>350			
Longitudinal limit force (static)	kN	60			120			240			
Lateral limit force (static)	kN	80			160			240			
Bending limit moment (static)	N·m	6000			12000			24000			
Oscillation width, as per DIN 50100 (peaktopeak) ¹¹⁾	kN·m	30	32		60			100			
Protection class, as per EN 60529 (rotor/stator)	-	IP 54									
Shunt											
Nominal (rated) trigger voltage	V	5									
Trigger voltage limit	V	36									
Calibration signal on	V_{min}	>2.5									
Calibration signal off	V_{max}	<0.7									
Tolerance of the shunt signal, related to M_{nom} at reference temperature	%	< ± 0.05									
Energy supply											
Nominal (rated) supply voltage (separated extralow voltage)	V_{DC}	18 ... 30									
Current consumption											
In measuring mode	A	<1 (typ. 0.3 at 20 V supply voltage)									
In startup mode	A	<4 (typ. 2) for max. 50 μ s									
Nominal (rated) power consumption	W	< 10 (typ. 6)									
Maximum cable length	m	50									

⁸⁾ Heat conductance via the stator base plate necessary over 70°C. The temperature of the base plate must not exceed 85°C.

⁹⁾ Each type of irregular stress (bending moment, lateral or longitudinal force, exceeding nominal (rated) torque) can only be permitted up to its specified static load limit, provided none of the others can occur at the same time. If this condition is not met, the limit values must be reduced. If 30% of the bending limit moment and lateral limit force occur at the same time, only 40% of the longitudinal limit force is permissible and the nominal (rated) torque must not be exceeded. The permissible bending moments, longitudinal forces and lateral forces can affect the measurement result by approx. 1 % of the nominal (rated) torque. The load limits only apply for the nominal (rated) temperature range. At temperatures <10°C, the load limits must be reduced by approx. 30% (viscosity reduction).

¹⁰⁾ The data refer to static loading of the measuring body; note the screw connections!

¹¹⁾ The nominal (rated) torque must not be exceeded.

Specifications (continued)

General Information										
EMC										
Emission , as per EN 61326-1, Section 7) RFI field strength	-	Class B								
Interference immunity , as per EN 61326-1, EN 61326-2-3										
Electromagnetic field (AM)	V/m	10								
Magnetic field	A/m	100								
Electrostatic discharge (ESD)										
Contact discharge	kV	4								
Air discharge	kV	8								
Rapid transients (burst)	kV	1								
Impulse voltages (surge)	kV	1								
Conducted interference (AM)	V	10								
Mechanical shock , as per EN 60068-2-72 ¹²⁾										
Number	n	1000								
Duration	ms	3								
Acceleration (half sine)	m/s ²	650								
Vibrational stress in 3 directions , as per EN 60068-2-6 ¹²⁾										
Frequency range	Hz	10 ... 2000								
Duration	h	2.5								
Acceleration (amplitude)	m/s ²	200								
Mechanical data										
Nominal (rated) torque M_{nom}	kN·m	15	20	25	30	40	50	60	70	80
Torsional stiffness c_T	kN·m/rad	32050			63260			106200		
Torsion angle at M_{nom}	Degree	0.027	0.036	0.045	0.027	0.036	0.045	0.033	0.038	0.043
Stiffness in the axial direction c_a	kN/mm	1380			1710			2280		
Stiffness in the radial direction c_r	kN/mm	3900			5080			6170		
Stiffness during the bending moment round a radial axis c_b	kN·m/deg	94			188			290		
Maximum deflection at longitudinal force limit	mm	<0.05			<0.08			<0.12		
Additional maximum radial run-out deviation at lateral limit force	mm	<0.05			<0.05			<0.05		
Additional maximum plane/parallel deviation at bending moment limit	mm	<0.5						<0.7		
Balance quality level , as per DIN ISO 1940		G 6.3								
Permissible max. limits for relative shaft vibration (peaktopeak) ¹³⁾ Undulations in area of connection flange, based on ISO 7919-3										
Normal operation (continuous operation)	μm	$s_{(p-p)} = \frac{9000}{\sqrt{n}}$ (n in min ⁻¹)								
Start and stop operation/resonance ranges (temporary)	μm	$s_{(p-p)} = \frac{13200}{\sqrt{n}}$ (n in min ⁻¹)								
Mass moment of inertia of rotor L_v (around the rotary axis; does not take flange bolts into account)	kg·m ²	0.2			0.46			0.75		
Proportional mass moment of inertia for the transmitter side (side of the flange with external centering)	%	28			23			26		
Permissible eccentricity of the rotor (radially) to the center point of the stator	mm	± 2								
Permissible axial displacement between rotor and stator ¹⁴⁾	mm	± 2								
Weight										
Rotor	kg	18			28			39		
Stator	kg	1.8			2.1			3.0		

¹²⁾ The antenna ring and connection plug must be fixed.

¹³⁾ The influence of radial run-out deviations, eccentricity, defects of form, notches, marks, local residual magnetism, structural variations or material anomalies needs to be taken into account and isolated from the actual wave oscillation.

¹⁴⁾ Above the nominal (rated) temperature range ±1.5 mm.

Dimensions T40FM 15 kNm – 25 kNm without speed measurement

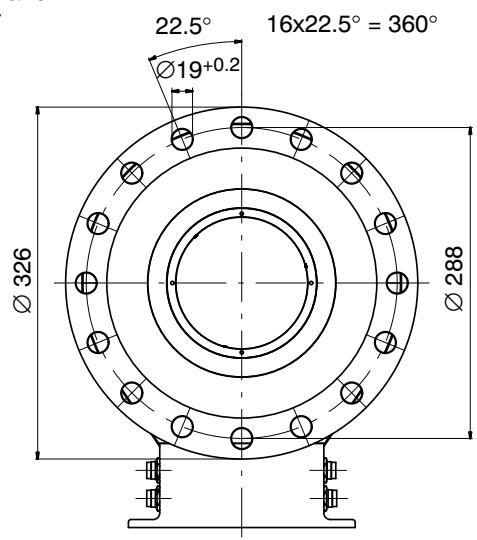
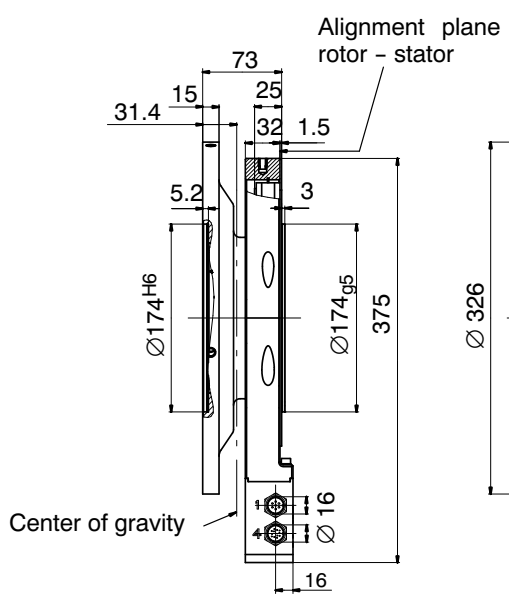
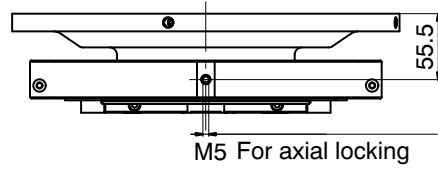
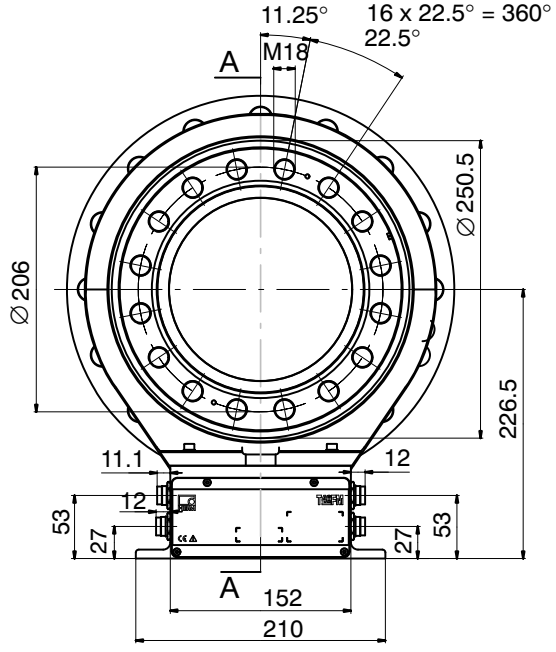
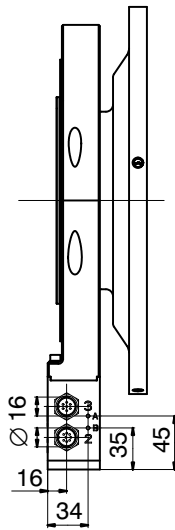
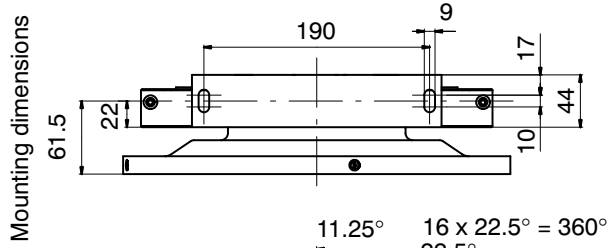

Cutaways in section A-A

Dimensions T40FM 30 kNm – 50 kNm without speed measurement

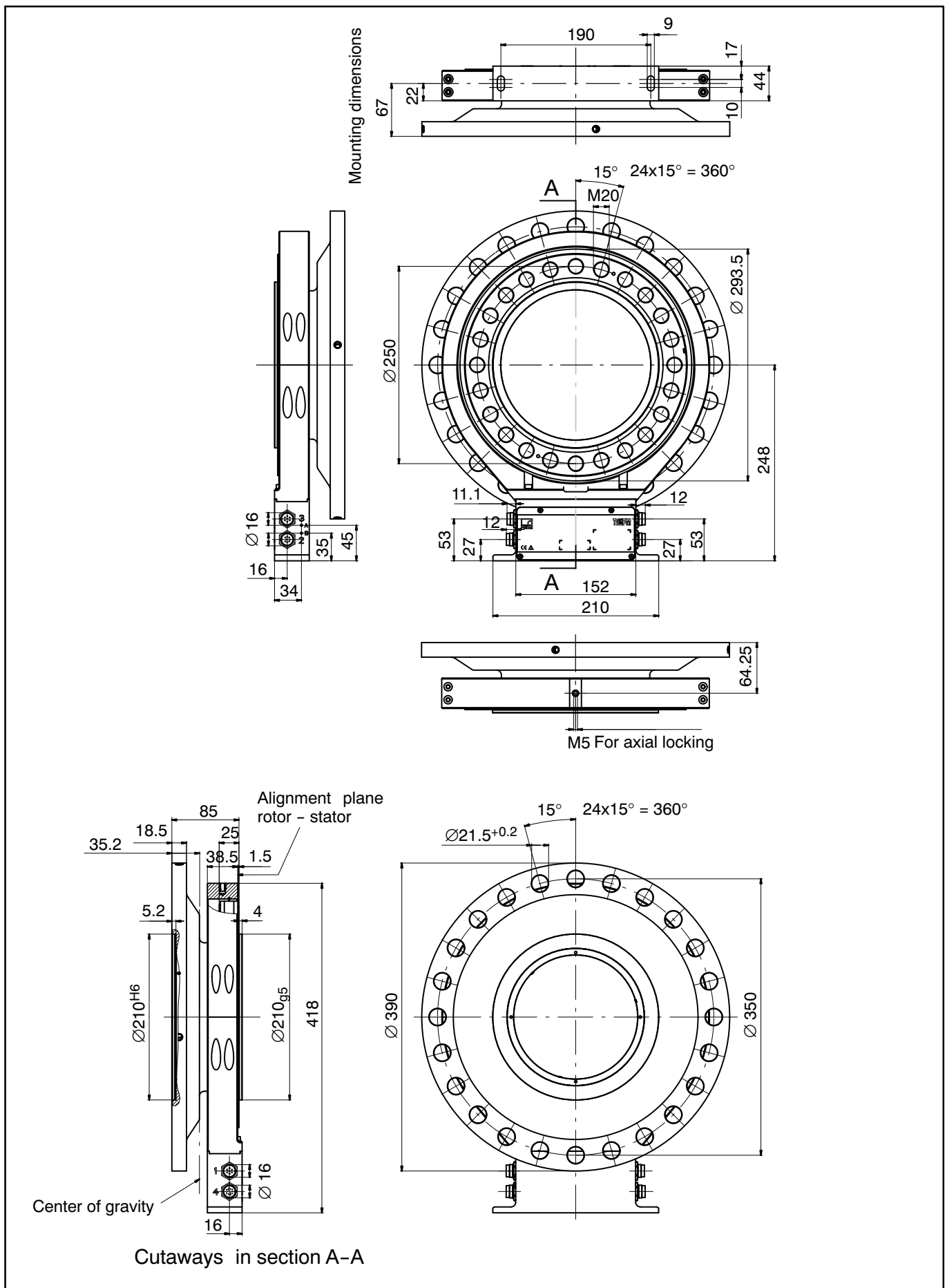

Dimensions T40FM 60 kNm – 80 kNm without speed measurement

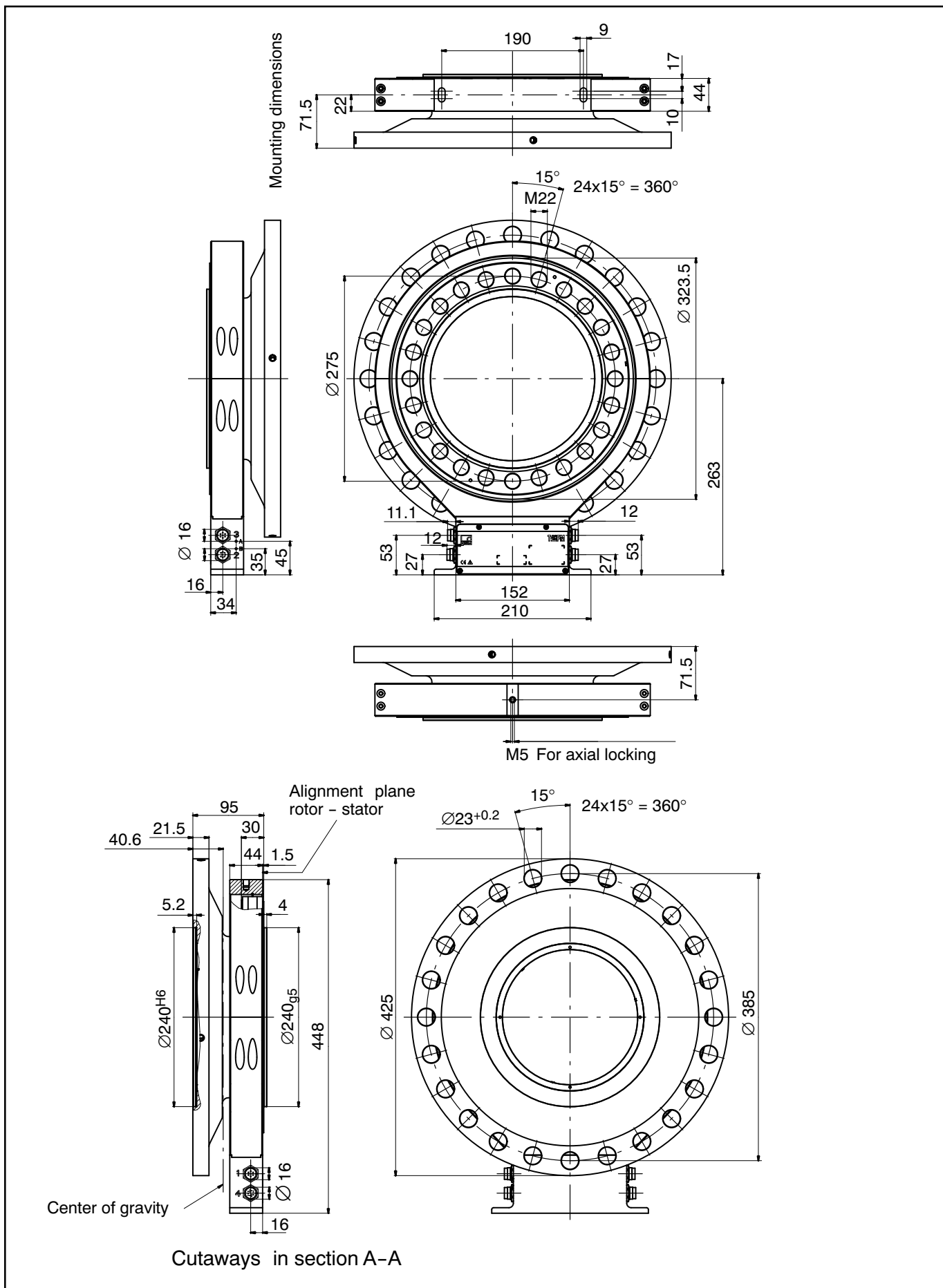

Dimensions T40FM 15 kNm – 25 kNm with speed measurement

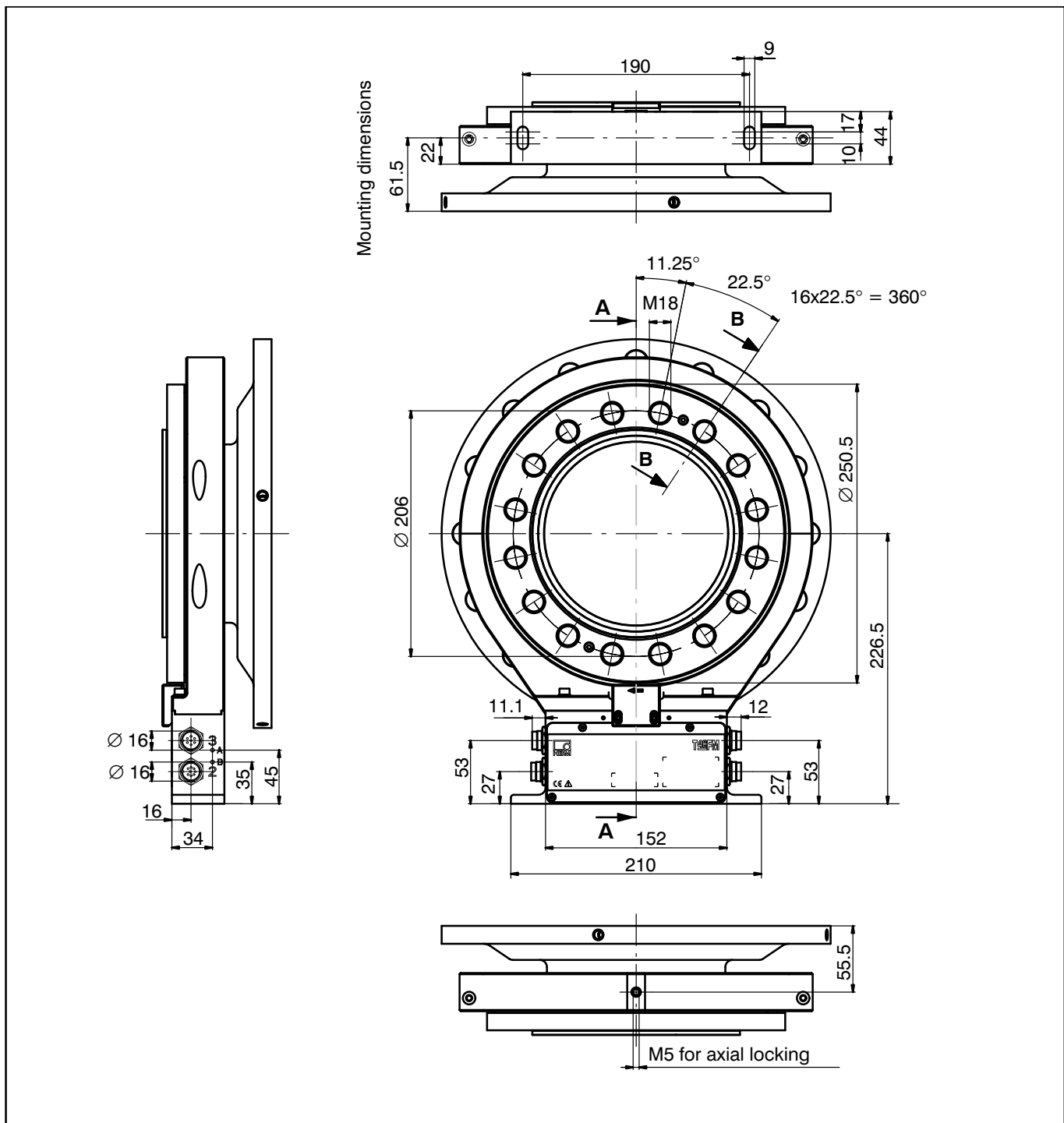

Dimensions T40FM 15 kNm – 25 kNm with speed measurement (continued)

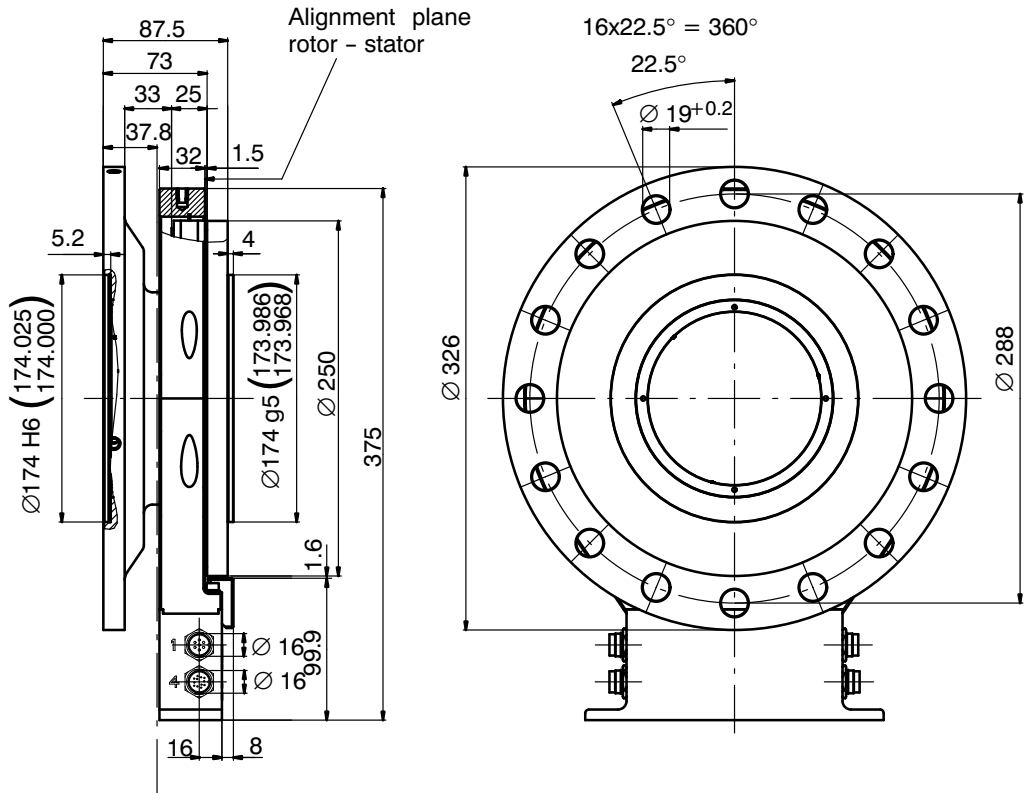

Center of gravity
Cutaways in section A-A

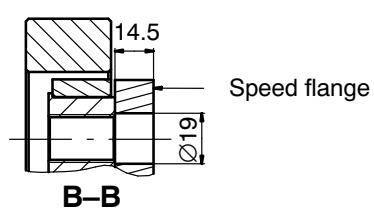

Dimensions T40FM 30 kNm – 50 kNm with speed measurement

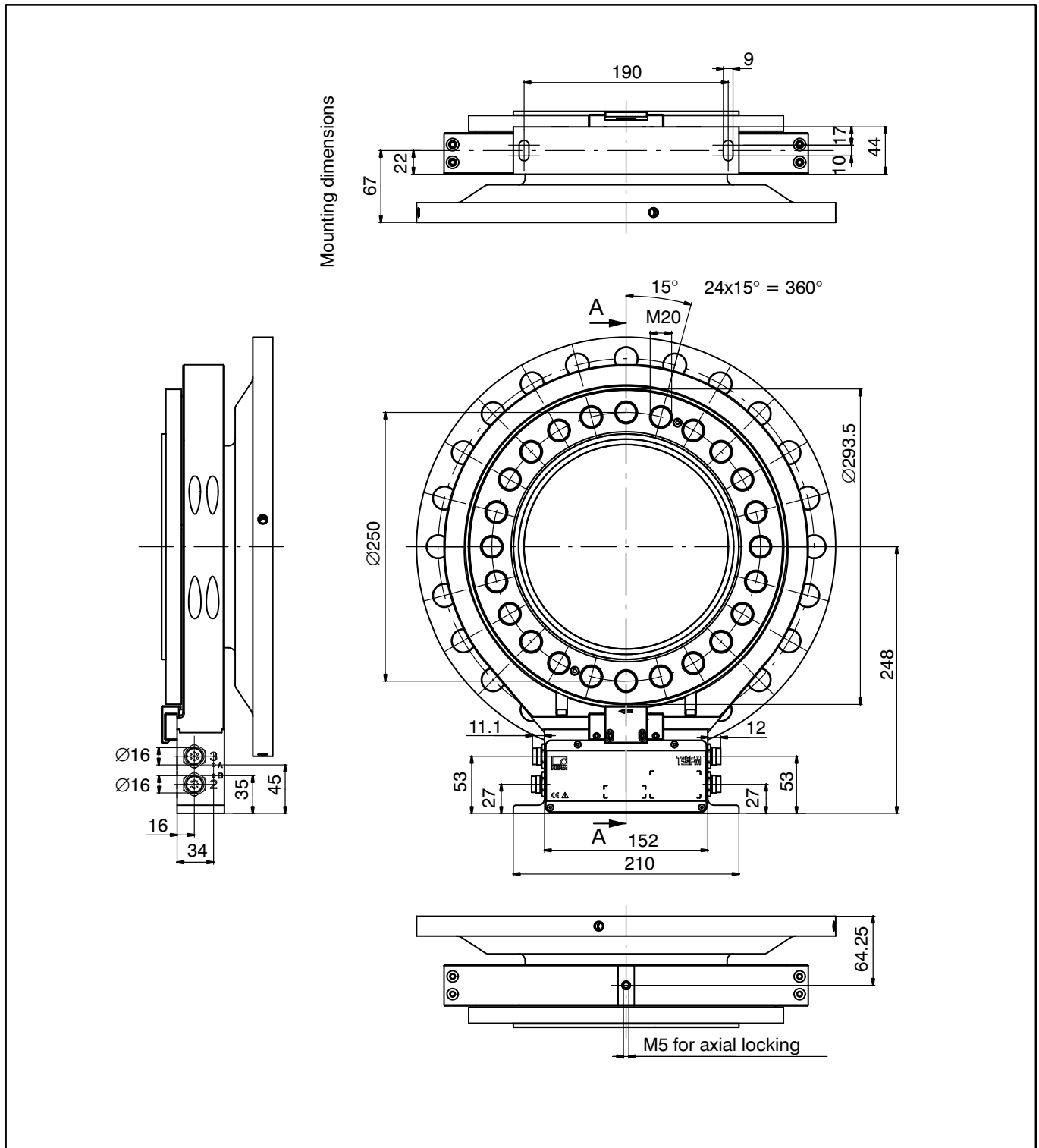

Dimensions T40FM 30 kNm – 50 kNm with speed measurement (continued)

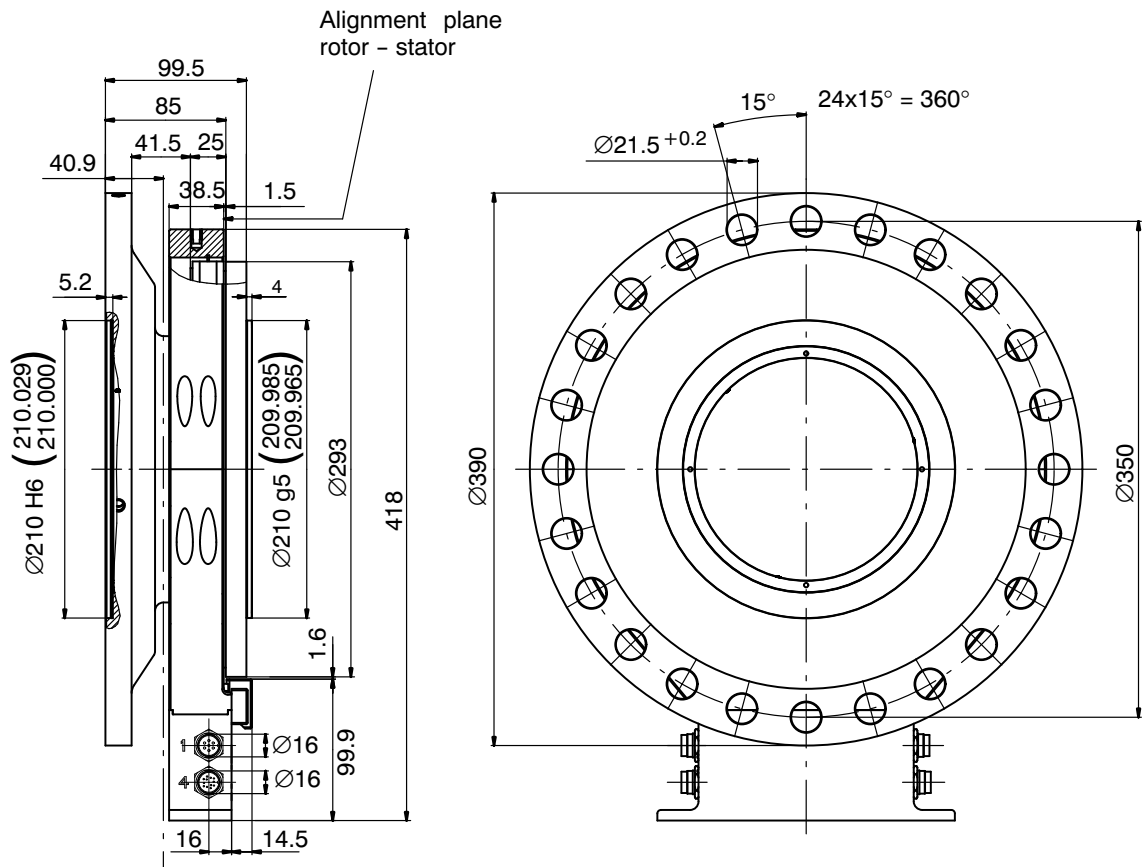

Center of gravity
Cutways in section A-A

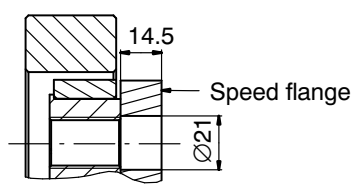

A-A

Dimensions T40FM 60 kNm – 80 kNm with speed measurement

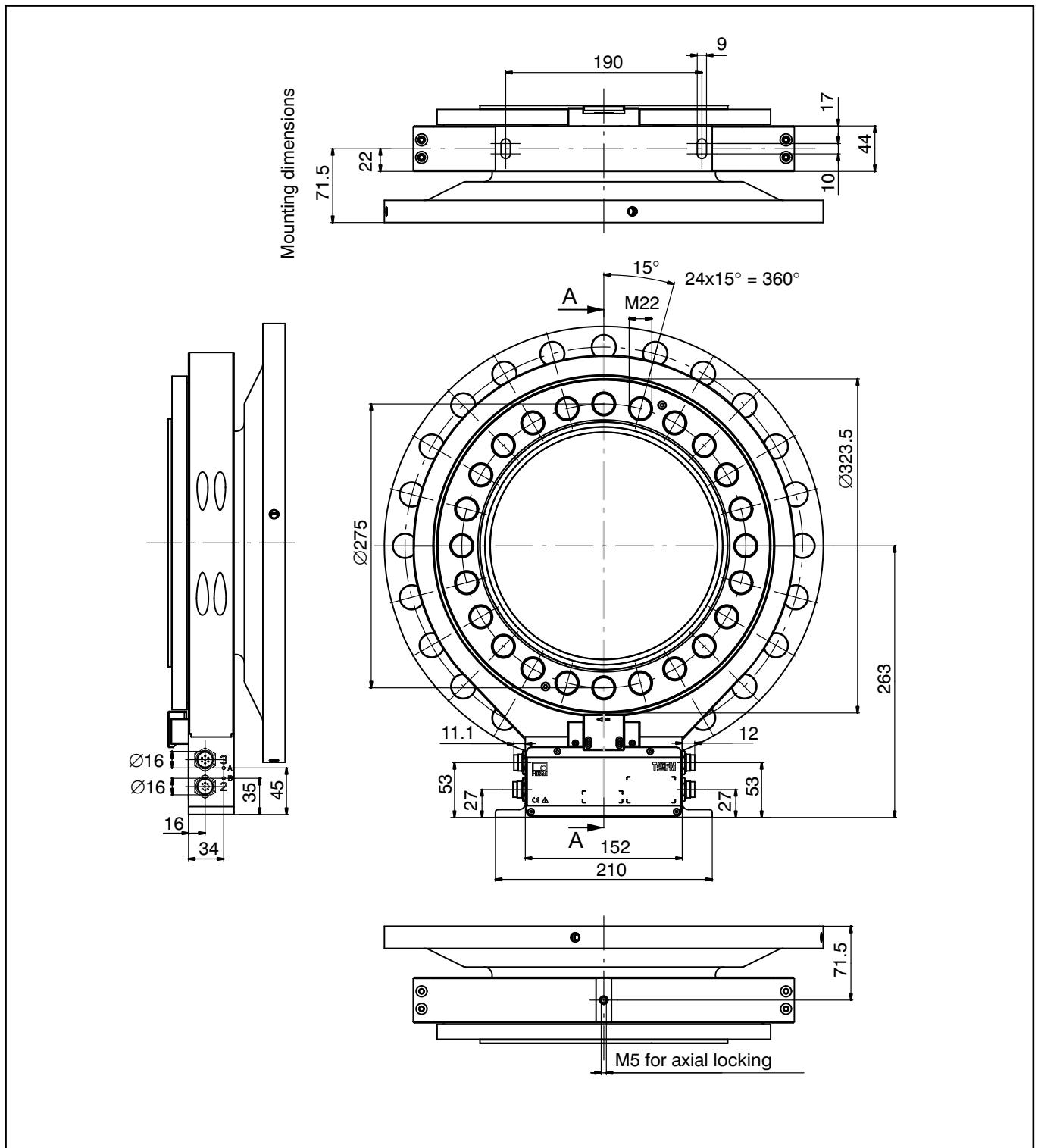

Dimensions T40FM 60 kNm – 80 kNm with speed measurement (continued)

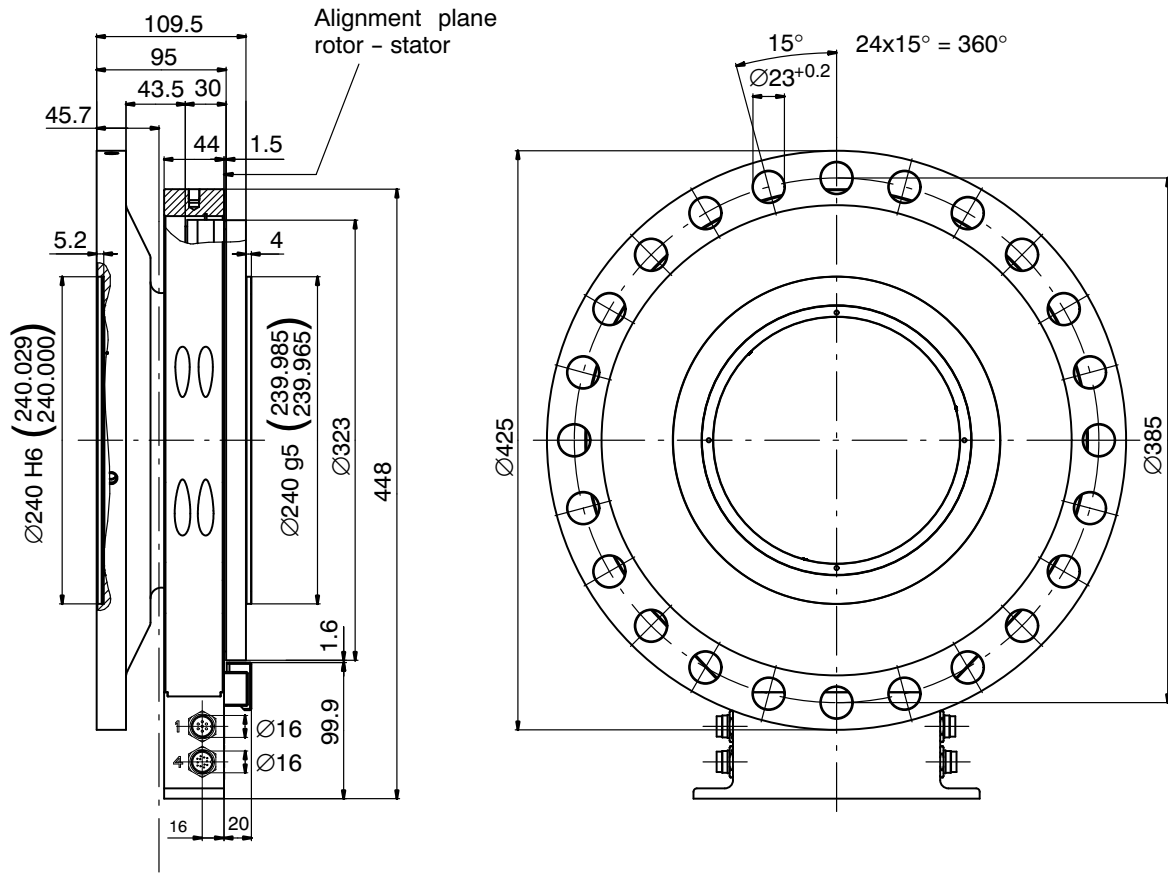

Center of gravity

Cutaways in section A-A

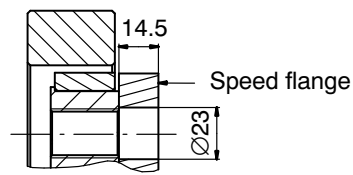

A-A

Radial and axial run-out tolerances

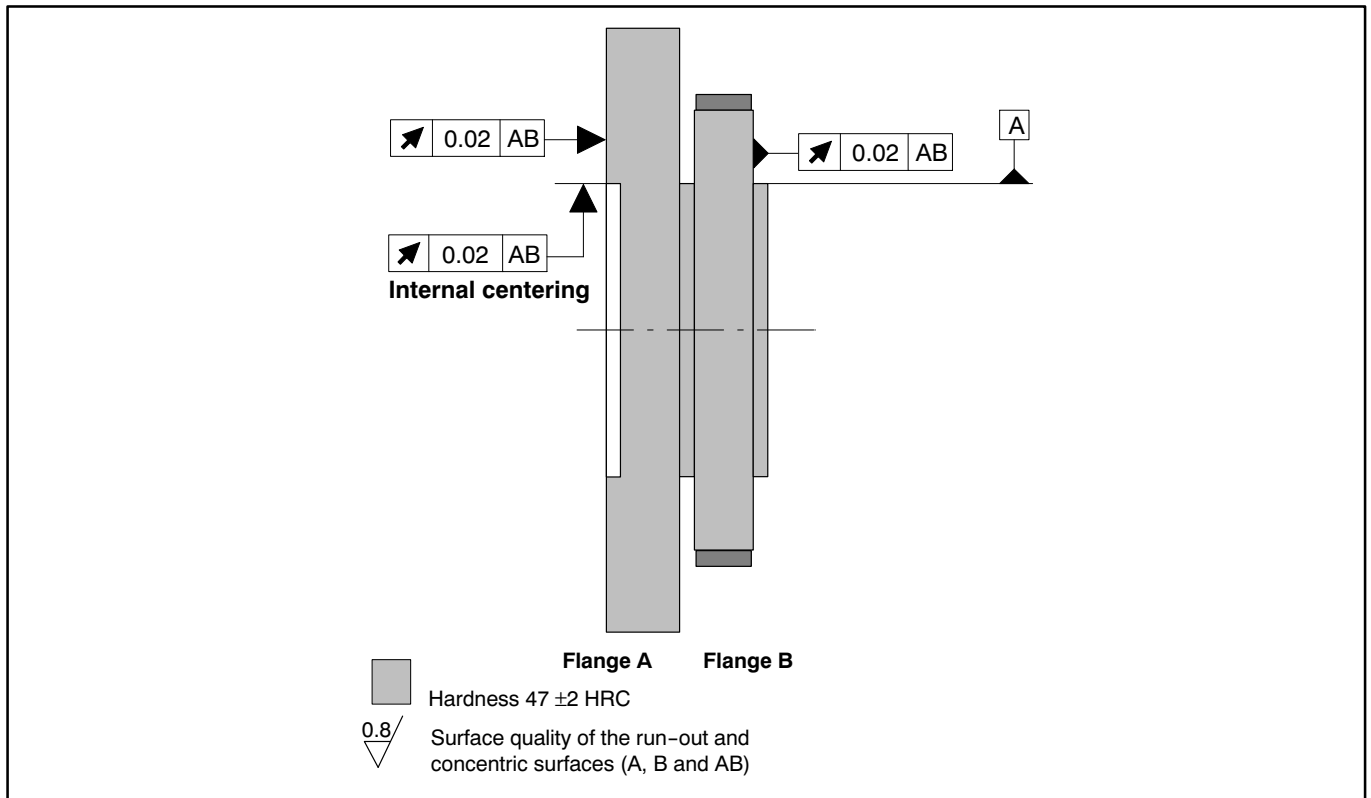

Fastening screws

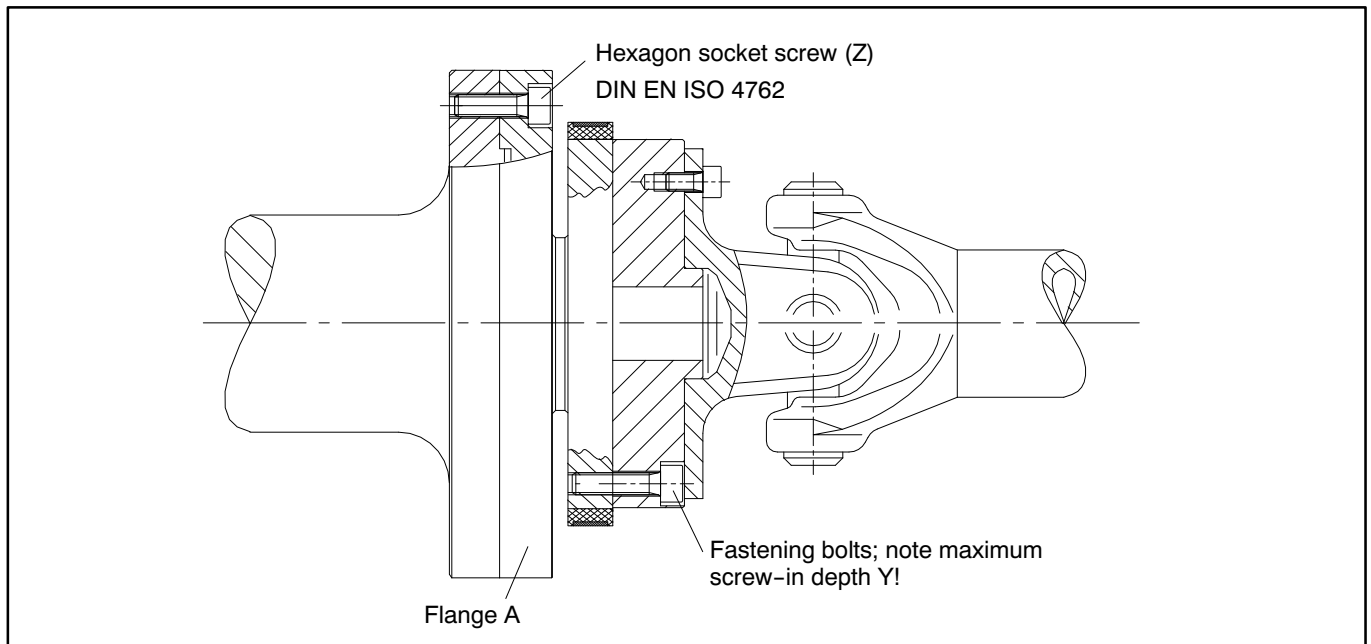

Measuring range (kN·m)	Fastening screws (Z) ¹⁾	Fastening screws Property class	Prescribed tightening torque (N·m)
15/20/25	M18	10.9	400
30/40/50	M20		560
60/70/80	M22		760

¹⁾ DIN EN ISO 4762; black/oiled/ $\mu_{tot} = 0.125$

order number

Order no.		
K-T40FM		Basic price Stator: [only with Option 2 = MF / ST]
Code	Option 1: Measuring range up to	
015R	15 kN·m	Basic price Rotor: [only with Option 2 = MF / RO]
020R	20 kN·m	Basic price Rotor: [only with Option 2 = MF / RO]
025R	25 kN·m	Basic price Rotor: [only with Option 2 = MF / RO]
030R	30 kN·m	Basic price Rotor: [only with Option 2 = MF / RO]
040R	40 kN·m	Basic price Rotor: [only with Option 2 = MF / RO]
050R	50 kN·m	Basic price Rotor: [only with Option 2 = MF / RO]
060R	60 kN·m	Basic price Rotor: [only with Option 2 = MF / RO]
070R	70 kN·m	Basic price Rotor: [only with Option 2 = MF / RO]
080R	80 kN·m	Basic price Rotor: [only with Option 2 = MF / RO]
Code	Option 2: Component	
MF	Measurement flange, complete	
RO	Rotor	
ST	Stator	
Code	Option 3: Accuracy	
S	Standard	
G	Linearity deviation including hysteresis < ±0.05	
Code	Option 4: Adjustment	
M	Metric (N·m)	
Code	Option 5: Electrical configuration [only with Option 2 = MF / ST]	
SU2	10 kHz ±5 kHz and ±10 V output signal, 18...30 V DC supply voltage	
DU2	60 kHz ±30 kHz and ±10 V output signal, 18...30 V DC supply voltage	
HU2	240 kHz ±120 kHz and ±10 V output signal, 18...30 V DC supply voltage	
Code	Option 6: Rot. speed measuring system	
0	Without rot. speed measuring system	
1	Magnetic rot. Speed measuring system; 1024 pulses/revolution	
Code	Option 7: Customised modification	
S	No customer-specific modification	
H	Permissible rotational speed, depending on measuring range 4500 rpm to 8000 rpm	
K-T40FM- 0 3 0 R - MF - S - M - DU 2 - 0 - S		☐ = PREFERENCE Types

Accessories, to be ordered separately

Article	Order No.
Connection cable, set	
Torque connection cable, 423 - D-Sub 15P, 6 m	1-KAB149-6
Torque connection cable, 423 - free ends, 6 m	1-KAB153-6
Connection cable TIM40/TMC, 6 m	1-KAB174-6
Cable sockets	
423G-7S, 7 pin (straight)	3-3101.0247
423W-7S, 7 pin (angle)	3-3312.0281
423G-8S, 8 pin (straight)	3-3312.0120
423W-8S, 8 pin (angle)	3-3312.0282
Connection cable, by the meter (min. order quantity: 10 m, price per meter)	
Kab8/00-2/2/2	4-3301.0071

Modifications reserved.

All details describe our products in general form only. They are not to be understood as express warranty and do not constitute any liability whatsoever.

Hottinger Baldwin Messtechnik GmbH

Im Tiefen See 45 · 64293 Darmstadt · Germany
Tel. +49 6151 803-0 · Fax: +49 6151 803-9100
Email: info@hbm.com · www.hbm.com

measure and predict with confidence

