

ACS 600 MultiDrive Modules





# ACS 600 MultiDrive Modules

## **Installation Manual**

3BFE 64119010 R0325  
EN  
EFFECTIVE: 19.9.2002



# Table of Contents

---

## Table of Contents

### Chapter 1 – Overview

Introduction . . . . .	1-1
What This Manual Contains . . . . .	1-1
Terms and Abbreviations Used in This Manual. . . . .	1-1

### Chapter 2 – Cabinet Assembly

General . . . . .	2-1
Disposition of the Devices . . . . .	2-1
Earthing of Module Mounting Structures . . . . .	2-1
Power Connections . . . . .	2-1
Busbar Material and Joints . . . . .	2-1
Tightening Torques . . . . .	2-1
Cooling and Degrees of Protection. . . . .	2-2
Constructing an Air Baffle . . . . .	2-3
Cubicle Heaters . . . . .	2-3
EMC Requirements . . . . .	2-4
Cabling. . . . .	2-4
Supply Units . . . . .	2-6
Cooling Conditions . . . . .	2-6
Effective Air Inlet/Outlet Areas. . . . .	2-8
Supply Module Power Connections . . . . .	2-9
Frame B2 . . . . .	2-12
Frame B3 . . . . .	2-14
Frame B4 . . . . .	2-16
Frame B5 . . . . .	2-20
Frames R6i to R12i (IGBT Supply Modules) . . . . .	2-24
Line (RFI) Filter . . . . .	2-25
B84143-A50-R37 . . . . .	2-25
B84143-A80-R37 . . . . .	2-26
B84143-B150-S21 . . . . .	2-27
B84143-B320-S21 . . . . .	2-27
B84143-B600-S21 . . . . .	2-28
B84143-B1000-S21 . . . . .	2-28
LCL Filters. . . . .	2-29
Internal Circuit Diagrams . . . . .	2-29
ISU_LCL_xR7. . . . .	2-30
ISU_LCL_xR8, ISU_LCL_xR9 . . . . .	2-31
ISU_LCL_xR11, ISU_LCL_xR12 . . . . .	2-35
DC Bus . . . . .	2-40
Drive Units/IGBT Supply Units . . . . .	2-42
Cooling Conditions . . . . .	2-42
Effective Air Inlet/Outlet Areas. . . . .	2-43

## Table of Contents

Inverter Module/IGBT Supply Module Power Connections . . . . .	2-44
Motor Cable Dimensioning . . . . .	2-48
Parallel Connection of Inverter Modules . . . . .	2-50
Parallel Connection of IGBT Supply Modules . . . . .	2-50
Frames R2i...R5i . . . . .	2-51
Frames R6i, R7i. . . . .	2-58
Installation without the Mounting Plate . . . . .	2-58
Frames R8i, R9i. . . . .	2-61
Installation Using the Mounting Frame . . . . .	2-62
Installing the Module in the Mounting Frame . . . . .	2-63
Installation without the Mounting Frame . . . . .	2-64
Frames R10i, R11i . . . . .	2-66
Installation Using the Mounting Frame . . . . .	2-67
Installation without the Mounting Frame . . . . .	2-69
Frame R12i . . . . .	2-73
Installation Using the Mounting Frame . . . . .	2-74
Installation without the Mounting Frame . . . . .	2-75
Common Mode Filters . . . . .	2-80
Dynamic Braking Units . . . . .	2-81
Braking Chopper Cubicle. . . . .	2-81
Resistor Cubicle. . . . .	2-84

## Chapter 3 – Wiring

Overview . . . . .	3-1
Precautions . . . . .	3-1
Notes on Optical Components . . . . .	3-1
Diode Supply Unit Control Wiring. . . . .	3-2
Thyristor Supply Unit . . . . .	3-5
Connecting the Circuit Boards. . . . .	3-5
Control Wiring . . . . .	3-6
IGBT Supply Unit Wiring . . . . .	3-9
Charging Circuit. . . . .	3-9
Control Wiring . . . . .	3-9
Connecting the NDCU Control Unit . . . . .	3-10
R10i...R12i Internal Wiring . . . . .	3-10
Varistor Board . . . . .	3-11
Drive Unit Wiring . . . . .	3-12
Charging Circuit. . . . .	3-12
Control Wiring . . . . .	3-13
Connecting the Control Unit. . . . .	3-16
Parallel-connected Modules . . . . .	3-17
R10i...R12i Internal Wiring . . . . .	3-18
The Emergency Stop Circuit . . . . .	3-19
Prevention of Unexpected Start . . . . .	3-21
NDIO/NAIO/NTAC I/O Module Connection . . . . .	3-22
Fieldbus Adapter Module Connection (Type Nxxx Modules) . . . . .	3-23
PC Connection . . . . .	3-24

Man/Machine Interface Installation . . . . .	3-25
Mechanical Installation . . . . .	3-25
Wiring . . . . .	3-27
Earthing . . . . .	3-28

**Appendix A – Circuit Diagrams**

Diode Supply Units . . . . .	A-2
Thyristor Supply Units . . . . .	A-5
IGBT Supply Units . . . . .	A-9
Switch Fuses with Charging Circuitry . . . . .	A-13
Drive Units . . . . .	A-16
Dynamic Braking Unit . . . . .	A-22

**Appendix B – Type Code Key**

*Table of Contents*



# Chapter 1 – Overview

---

## **Introduction**

This Manual contains instructions for installing, and designing a cabinet for, ACS 600 MultiDrive Modules components.

## **What This Manual Contains**

**Chapter 2** gives instructions for building the cabinet (e.g. cooling, EMC compliance), and for installing the components.

**Chapter 3** includes control wiring examples and instructions.

**Appendix A** contains basic circuit diagrams for ACS 600 MultiDrive Modules components.

**Appendix B** contains a type code key for the ACN 6x4 power modules.

---

**Note:** A CD-ROM containing relevant circuit diagrams, dimensional drawings, component selection tables, manuals and other documentation is available. Contact your local ABB representative.

---

## **Terms and Abbreviations Used in This Manual**

### *DDCS*

Distributed Drives Communication System (a communication protocol used in optical fibre communication inside and between ABB drives).

### *Drive Unit*

An entity containing all inverter modules controlling one motor, together with their control electronics, I/O and auxiliary components.

### *DSU*

Diode Supply Unit.

### *DTC*

Direct Torque Control.

### *EMC*

Electromagnetic Compatibility.

### *EMS*

Emergency Stop.

### *Frame*

Refers to the construction class of the component in question. For example, four supply modules with different nominal powers may have the same basic construction, i.e. frame. This term is often used as a reference to a group of components which have a similar construction.

The frame of each component is given in the selection tables in the appropriate chapter.

*IGBT*

Insulated Gate Bipolar Transistor (a voltage-controlled semiconductor type widely used in inverters due to their easy controllability and high switching frequency).

*I/O*

Input/output.

*ISU*

IGBT Supply Unit.

*Kalei Nut*

(In dimensional drawings) A type of self-clinching nut.

*(N)AMC*

The Application and Motor Controller board of the ACS 600.

*NDCU*

The Drive Control Unit. The NDCU consists of a NAMC board and a NIOC board, built into a metal housing.

*NIOC*

The standard Input/Output Board of the ACS 600.

*LCD*

Liquid Crystal Display.

*LED*

Light Emitting Diode.

*PLC*

Programmable Logic Controller.

*PPCS*

Power Plate Communication System (a communication protocol used in the optical fibre link that controls the output semiconductors of an inverter).

*RFI*

Radio Frequency Interference.

*TSU*

Thyristor Supply Unit.

## Chapter 2 – Cabinet Assembly

---

### **General**

The cabinet properties discussed below are essential for safe and efficient use of the drive system. This section also includes guidelines for fulfilling EMC requirements.

### **Disposition of the Devices**

The cabinet frame must be sturdy enough to carry the weight of the drive components, control circuitry and other equipment installed in it. For easy installation and maintenance, a spacious layout is recommended. Sufficient cooling air flow, obligatory clearances, cables, cable support structures, and EMC shielding all require space.

The control boards must not be installed near a main circuit or hot parts.

### **Earthing of Module Mounting Structures**

Make sure that any cross-members or shelves on which the modules are mounted are properly earthed, and the connecting surfaces left unpainted.

### **Power Connections**

#### **Busbar Material and Joints**

Tin-plated copper is recommended.

Aluminium busbars can also be used. Before joining aluminium busbars, the oxide layer must be removed and suitable anti-oxidant joint compound applied.

---

**Note:** Some ACS 600 MultiDrive Modules components (such as filters) have aluminium busbars. Follow the above instructions when joining these components.

---

### **Tightening Torques**

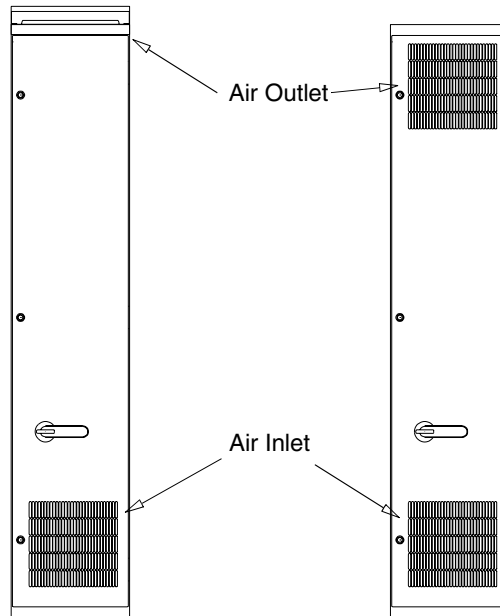
The following table is applicable to zinc and chrome platings, and grade 8.8 screws (with or without joint compound).

Screw size	Torque (Nm)	
	Soft aluminium	Alloyed aluminium and copper
M5	3.5	3.5
M6	6	9
M8	17	20
M10	35	40
M12	55	70
M16	130	180

**Cooling and Degrees of Protection**

The cabinet must have enough free space for the components to ensure sufficient cooling. Observe the minimum clearances given for each component.

The drawing below shows two typical cabinet cooling solutions. The air inlet is at the bottom of the cabinet, while the outlet is at the top, either on the upper part of the door or on the roof.

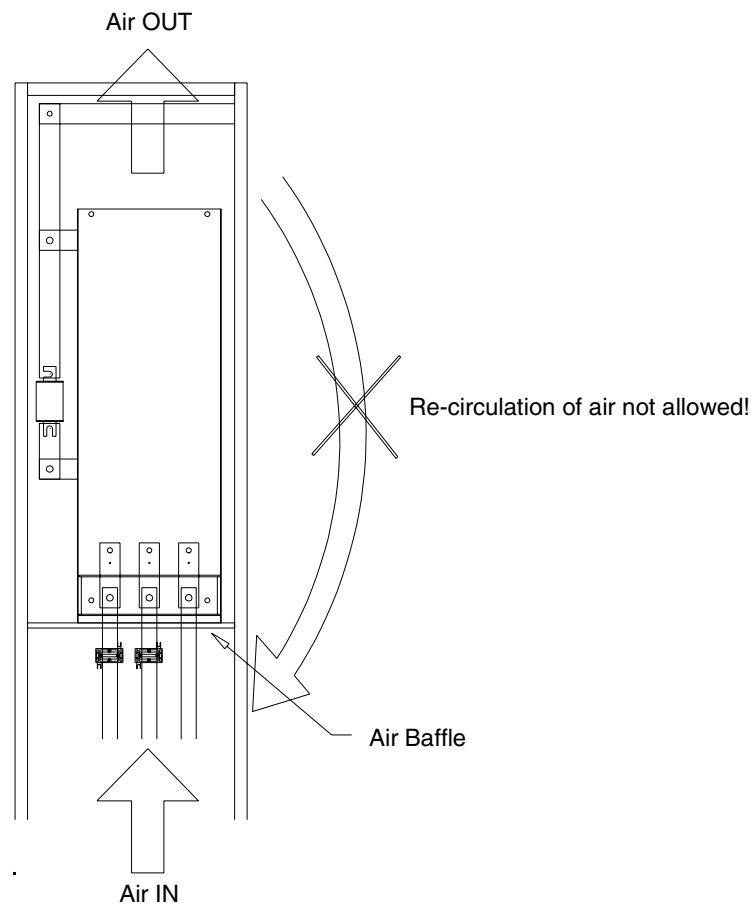


The supply and inverter units (as well as reactors/chokes) are equipped with cooling fans which are usually sufficient to keep the temperatures of the components low enough in an IP22-protected cabinet. If IP54 protection is required, thicker filter mats must be used to prevent water splashes from entering the cabinet. This entails the installation of additional cooling equipment, such as a hot air exhauster. (An intake blower cannot be used because of the pumping action between the cabinet and module fans.) If cool process water is available, a water/air heat exchanger is an efficient solution.

It must be ensured that the hot air leaving the cabinet does not re-enter the cabinet (or other cabinets) through the inlet.

*Constructing an Air Baffle*

With Frame B2...B5 supply modules, DC reactors, LCL filters and Frame R6i...4xR12i inverter/IGBT supply modules, the circulation of hot air inside the cabinet must be prevented with an air baffle. A dimensional drawing of the baffle for each supply and inverter module is presented on the following pages. Note that the final width of the air baffle depends on the cabinet it is installed in; the drawings give the minimum distances to fulfil the clearance requirements.



*Figure 2-1 Example of a supply module installation.*

The air baffle can be made out of steel sheet. Some installations require that the baffle be made strong enough to support the weight of the components. The baffle must be almost leak-proof; however, no gaskets are required. The position of the air baffle is important – it must be installed at the level shown in the cabinet layout example diagrams later in this chapter.

*Cubicle Heaters*

A cubicle heater must be used if there is a risk of condensation in the cabinet. Although the primary function of the heater is to keep the air dry, it may also be required for heating at low temperatures. When placing the heater, follow the instructions provided by its manufacturer.

**EMC Requirements**

Generally, the fewer and smaller the holes in the cabinet, the better the interference attenuation. The maximum diameter of a hole in galvanic metal contact in the covering cabinet structure is 100 mm. Special attention must be paid to the cooling air inlet and outlet grates.

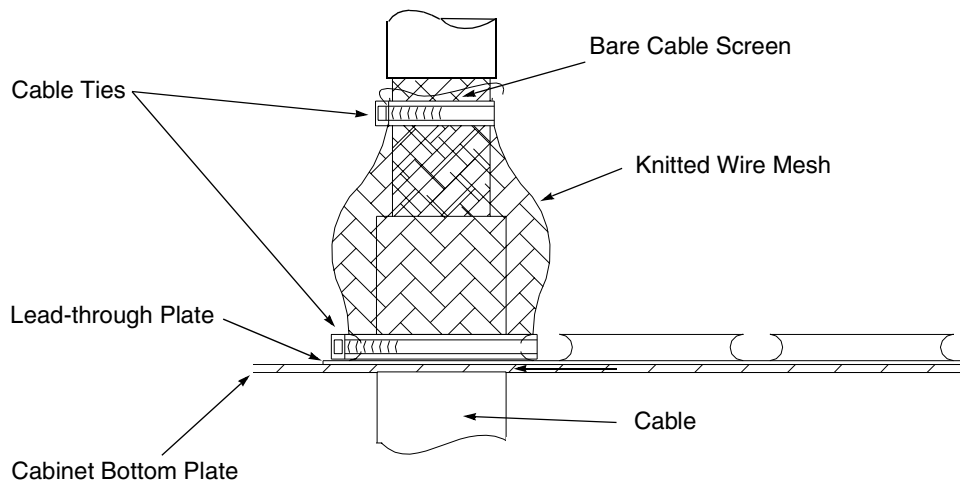
The best galvanic connection between the steel panels is achieved by welding them together as no holes are necessary. If welding is not possible, the seams between the panels **must be left unpainted** and equipped with special conductive EMC strips to provide adequate galvanic connection. Usually, reliable strips are made of flexible silicon mass covered with a metal mesh. The non-tightened touch-contact of the metal surfaces is not sufficient, so a conductive gasket between the surfaces is required. The maximum distance between assembly screws is 100 mm.

Sufficient high-frequency earthing network must be constructed in the cabinet to avoid voltage differences and forming of high-impedance radiator structures. A good high-frequency earthing is made with short flat copper braids for low inductance. One-point high-frequency earthing cannot be used due to the long distances inside the cabinet.

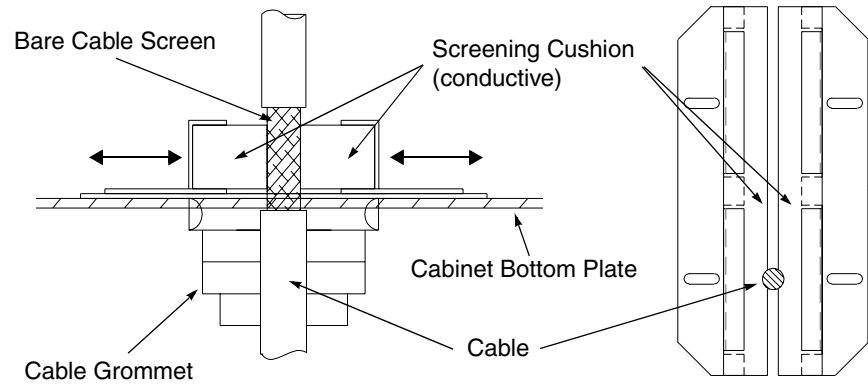
On the other hand, a sturdy low-frequency earthing structure is required for electrical safety of the parts. Conductive EMC shielding gasket tapes are not sufficient for protective earthing. Please follow the local regulations when designing protective earthing.

The cabinet doors must be galvanically connected to the cabinet, and sealed with conductive EMC strip without gaps.

**Cabling** EMC compliance requires 360° high-frequency earthing of the screens of power cables at their entries. For the motor cables, the earthing can be implemented using a knitted wire mesh screening as shown below.



Signal cables can be earthed by means of conductive cushions, pressed against the cable screen from both sides.



**Supply Units**

**Cooling Conditions** The tables below show the general cooling conditions and recommended effective air inlet/outlet areas for the supply modules and DC reactor/LCL filter cabinets.

Module Frame	Max. IN Air Temp. [°C]	Max. Air Temp. Rise [°C]	Min. Airflow per Module [m <sup>3</sup> /h]	Pressure Difference over Module [Pa]	Max. Pressure Drop of Cabinet [Pa]	Cooling Fan		
						Voltage [V]	Type	
<i>Diode and Thyristor Supply Modules</i>								
B2	40	10	370	(Data not available)	40	230	W2E200-HH38-06	
						115	W2E200-HH82-11	
B3	40	15	770		70	230	W2E250-HL06-05	
						115	W2E250-HL08-06	
B4	40	23	1000		70	230	RD25S4EW,4I,AL (Art. No. 121825)	
						115	RD25S4EW,4I,AL (Art. No. 121745)	
B5	40	22	1700		74	230	GR31M2DK 3F2R (Art. No. 120620)	
						115	GR31M2DK 3F2R (Art. No. 120621)	
<i>DC Reactors</i>								
B4 – DC Reactor	40	30	500		80	10	230	W2E200-HH38-06
				115			W2E200-HH82-11	
B5 – DC Reactor	40	30	500	80	10	230	W2E200-HH38-06	
						115	W2E200-HH82-11	



Module		Max. IN Air Temp. [°C]	Max. Air Temp. Rise [°C]	Min. Airflow per Module [m <sup>3</sup> /h]	Pressure Diff. over Module [Pa]	Max. Pressure Drop of Cabinet [Pa]	Cooling Fan	
Frame	Voltage [V]						Voltage [V]	Type
<i>IGBT Supply Modules</i>								
R6i	400/500	40	24	480	116	67	230	G2E140-AI51-ABB
	690		14				115	G2E140-AI32-ABB
R7i	400/500	40	18	480	116	67	230	G2E140-AI51-ABB
	690		21				115	G2E140-AI32-ABB
R8i	400/500	40	8	1550	222	74	230	D4E225-CC01-39
	690						115	D4E225-CC07-37
R9i	400/500	40	11	1550	222	74	230	D4E225-CC01-39
	690		9				115	D4E225-CC07-37
R10i	400/500	40	5	3100	210	86	230	2 × D4E225-CC01-39
	690						115	2 × D4E225-CC07-37
R11i	400/500	40	7	3100	210	86	230	2 × D4E225-CC01-39
	690		5				115	2 × D4E225-CC07-37
R12i	400/500	40	8	4650	220	76	230	3 × D4E225-CC01-39
	690						115	3 × D4E225-CC07-37
<i>LCL Filters</i>								
ISU_LCL_xR7		40	(Data not available)	480			230	G2E140-AI51-ABB
							115	G2E140-AI32-ABB
ISU_LCL_xR8 ISU_LCL_xR9		40	15	550			230	D2E133-CF01
							115	D2E133-CO67
ISU_LCL_5R11		40	25	725			230	D2E146-AP47-79
							115	D2E146-AP51-80
ISU_LCL_6R11		40	27	725		(Data not available)	230	D2E146-AP47-79
							115	D2E146-AP51-80
ISU_LCL_5R12		40	39	725			230	D2E146-AP47-79
							115	D2E146-AP51-80
ISU_LCL_6R12		40	38	725			230	D2E146-AP47-79
							115	D2E146-AP51-80

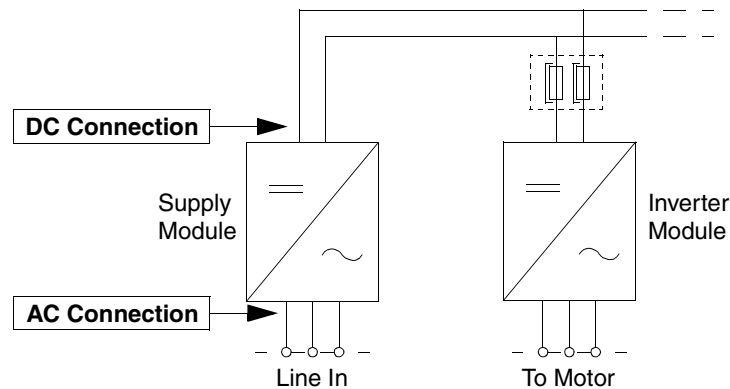
*Effective Air Inlet/Outlet Areas*

<b>Frame/ Module</b>	<b>Effective Air Inlet Area [m<sup>2</sup>]</b>	<b>Effective Air Outlet Area [m<sup>2</sup>]</b>	<b>Filter Material</b>
B2	0.065	0.065	Air-Tex G-150
B3, B4	0.109	0.109	
B5	0.217	0.109	
DC Reactor	0.065	0.065	
R6i, R7i	0.065	0.065	
R8i, R9i	0.217	0.109	
R10i, R11i	0.347	0.195	
R12i	0.521	0.304	
ISU_LCL_xR7	0.167	0.083	
ISU_LCL_xR8 ISU_LCL_xR9	0.341	0.191	
ISU_LCL_xR11 ISU_LCL_xR12	0.347	0.195	

**Supply Module Power Connections**

The table below shows the power connection types and recommended internal cable/busbar cross-sectional areas for the supply modules.

**Note:** The table is valid for the cables/busbars inside the drive cabinet line-up only. External supply cables/busbars have to be dimensioned separately. For information, refer to *Grounding and cabling of the drive system* (3AFY 61201998).



Supply Module Type	AC Connection			DC Connection		
	Connection Type		Cross-section (per leg)	Connection Type		Cross-section (per leg)
	Cable Lug	Connection Hole for Busbar		Cable Lug	Connection Hole for Busbar	
<i>Diode Supply Modules (U<sub>N</sub> = 500 V)</i>						
ACN 684 0175 5	–	Ø 11 mm	4 × 25 mm	–	Ø 11 mm	6 × 30 mm
ACN 684 0250 5	–	Ø 11 mm	4 × 25 mm	–	Ø 11 mm	6 × 30 mm
ACN 684 0375 5	–	Ø 13 mm	8 × 30 mm	–	Ø 13 mm	8 × 40 mm
ACN 684 0525 5	–	Ø 13 mm	8 × 30 mm	–	Ø 13 mm	8 × 40 mm
ACN 684 0855 5	–	4 × Ø 13 mm	10 × 100 mm	–	Ø 14 mm	10 × 100 mm
ACN 684 1405 5	–	4 × Ø 13 mm	10 × 100 mm	–	Ø 14 mm	10 × 100 mm
ACN 684 2120 5	–	4 × Ø 13 mm	2 × (10 × 100 mm)	–	Ø 14 mm	2 × (10 × 100 mm)
ACN 684 2600 5	–	4 × Ø 13 mm	2 × (10 × 100 mm)	–	Ø 14 mm	2 × (10 × 100 mm)
<i>(Continued)</i>						

(Continued)						
Supply Module Type	AC Connection			DC Connection		
	Connection Type		Cross-section (per leg)	Connection Type		Cross-section (per leg)
	Cable Lug	Connection Hole for Busbar		Cable Lug	Connection Hole for Busbar	
<i>Diode Supply Modules (<math>U_N = 690\text{ V}</math>)</i>						
ACN 684 0090 6	–	Ø11 mm	4 × 25 mm	–	Ø11 mm	6 × 30 mm
ACN 684 0175 6	–	Ø11 mm	4 × 25 mm	–	Ø11 mm	6 × 30 mm
ACN 684 0250 6	–	Ø13 mm	4 × 25 mm	–	Ø11 mm	6 × 30 mm
ACN 684 0375 6	–	Ø13 mm	8 × 30 mm	–	Ø13 mm	8 × 40 mm
ACN 684 0525 6	–	Ø13 mm	8 × 30 mm	–	Ø13 mm	8 × 40 mm
ACN 684 0855 6	–	4 × Ø13 mm	10 × 100 mm	–	Ø14 mm	10 × 100 mm
ACN 684 1405 6	–	4 × Ø13 mm	10 × 100 mm	–	Ø14 mm	10 × 100 mm
ACN 684 2600 6	–	4 × Ø13 mm	2 × (10 × 100 mm)	–	Ø14 mm	2 × (10 × 100 mm)
ACN 684 3600 6	–	4 × Ø13 mm	2 × (10 × 100 mm)	–	Ø14 mm	2 × (10 × 100 mm)
<i>Thyristor Supply Modules (<math>U_N = 500\text{ V}</math>)</i>						
ACN 674 0175 5	–	Ø11 mm	4 × 25 mm	–	Ø11 mm	6 × 30 mm
ACN 674 0250 5	–	Ø11 mm	4 × 25 mm	–	Ø11 mm	6 × 30 mm
ACN 674 0375 5	–	Ø10 mm	8 × 30 mm	–	Ø11 mm	8 × 40 mm
ACN 674 0525 5	–	Ø10 mm	8 × 30 mm	–	Ø11 mm	8 × 40 mm
ACN 654/664 0855 5	–	4 × Ø13 mm	10 × 100 mm	–	Ø14 mm	10 × 100 mm
ACN 654/664 1405 5	–	4 × Ø13 mm	10 × 100 mm	–	Ø14 mm	10 × 100 mm
ACN 654/664 2120 5	–	4 × Ø13 mm	2 × (10 × 100 mm)	–	Ø14 mm	2 × (10 × 100 mm)
ACN 654/664 2600 5	–	4 × Ø13 mm	2 × (10 × 100 mm)	–	Ø14 mm	2 × (10 × 100 mm)
(Continued)						

(Continued)						
Supply Module Type	AC Connection			DC Connection		
	Connection Type		Cross-section (per leg)	Connection Type		Cross-section (per leg)
	Cable Lug	Connection Hole for Busbar		Cable Lug	Connection Hole for Busbar	
<i>Thyristor Supply Modules (<math>U_N = 690\text{ V}</math>)</i>						
ACN 674 0090 6	–	Ø11 mm	4 × 25 mm	–	Ø11 mm	6 × 30 mm
ACN 674 0175 6	–	Ø11 mm	4 × 25 mm	–	Ø11 mm	6 × 30 mm
ACN 674 0250 6	–	Ø11 mm	4 × 25 mm	–	Ø11 mm	6 × 30 mm
ACN 674 0375 6	–	Ø10 mm	8 × 30 mm	–	Ø11 mm	8 × 40 mm
ACN 674 0525 6	–	Ø10 mm	8 × 30 mm	–	Ø11 mm	8 × 40 mm
ACN 654/664 0855 5	–	4 × Ø13 mm	10 × 100 mm	–	Ø14 mm	10 × 100 mm
ACN 654/664 1405 5	–	4 × Ø13 mm	10 × 100 mm	–	Ø14 mm	10 × 100 mm
ACN 654/664 2120 5	–	4 × Ø13 mm	2 × (10 × 100 mm)	–	Ø14 mm	2 × (10 × 100 mm)
ACN 654/664 2600 5	–	4 × Ø13 mm	2 × (10 × 100 mm)	–	Ø14 mm	2 × (10 × 100 mm)
<i>Thyristor Supply Modules (<math>U_N = 830\text{ V}</math>)</i>						
ACN 654 1685 8	–	4 × Ø13 mm	10 × 100 mm	–	Ø14 mm	10 × 100 mm
ACN 654 3100 8	–	4 × Ø13 mm	10 × 100 mm	–	Ø14 mm	10 × 100 mm
ACN 654 3520 8	–	4 × Ø13 mm	2 × (10 × 100 mm)	–	Ø14 mm	2 × (10 × 100 mm)
ACN 654 4310 8	–	4 × Ø13 mm	2 × (10 × 100 mm)	–	Ø14 mm	2 × (10 × 100 mm)
<i>IGBT Supply Modules</i>						
IGBT supply modules utilise the same hardware as inverter modules. See table under <b><i>Inverter Module/IGBT Supply Module Power Connections</i></b> (starting page 2-44) for connection data.						

**Frame B2** Frame B2 supply modules are fixed to the rear wall of the cabinet with four screws. An air baffle must be used to prevent air from circulating inside the cabinet. The baffle should be strong enough to support the weight of the module in order to facilitate the mounting; Figure 2-4 shows a suitable design. The input and output connections (located at the bottom and top of the module respectively) are made using busbars.

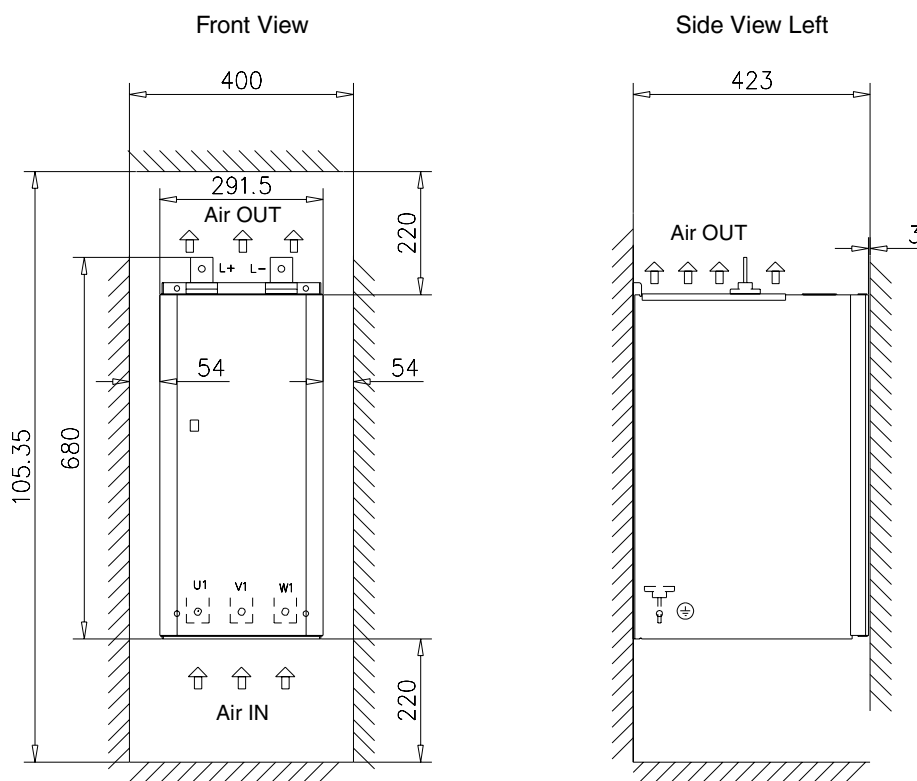


Figure 2-2 Frame B2 supply module dimensions and clearances.

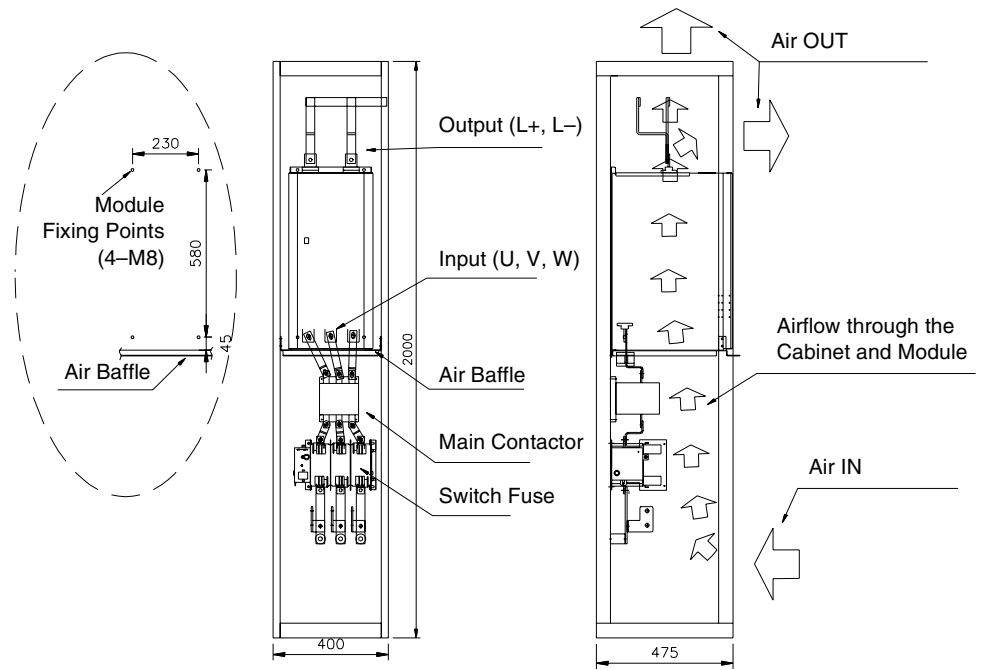


Figure 2-3 Cabinet layout example for Frame B2 supply unit.

MATERIAL: HOT-DIP ZINC COATED STEEL SHEET 2mm  
 EN 10142-DX51D+Z275-N-A-C  
 DIMENSION WITHOUT TOLERANCE DIN 6930-m

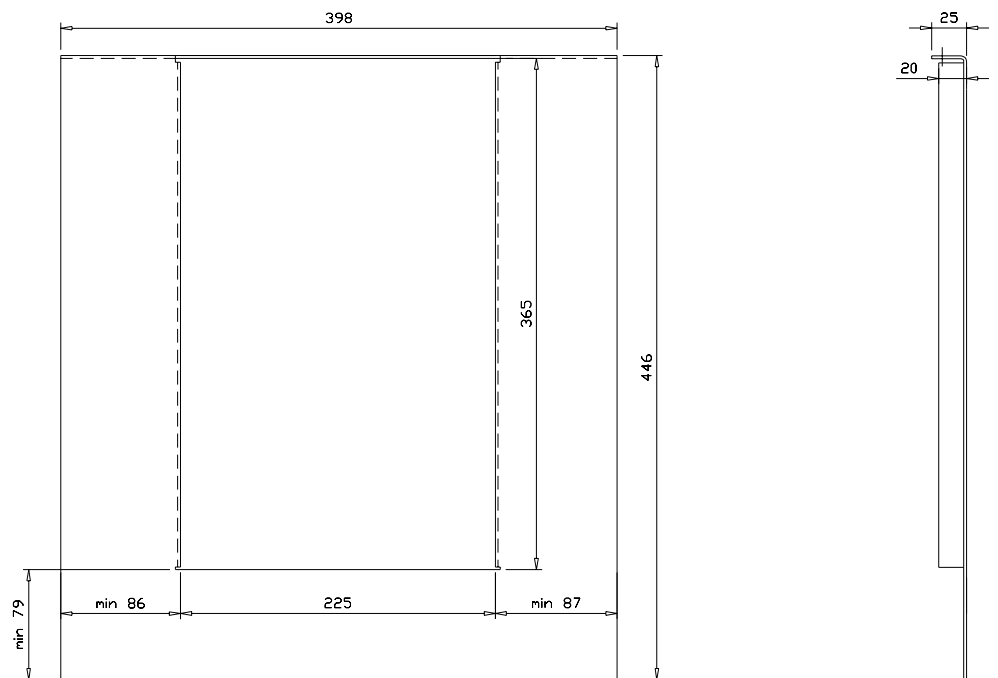


Figure 2-4 Air baffle for Frame B2 supply module.

**Frame B3** Frame B3 supply modules are fixed to the rear wall of the cabinet with four M8 screws. An air baffle must be used to prevent air from circulating inside the cabinet. The baffle should be strong enough to support the weight of the module in order to facilitate the mounting; Figure 2-7 shows a suitable design. The input and output connections (located at the bottom and left side of the module respectively) are made using busbars.

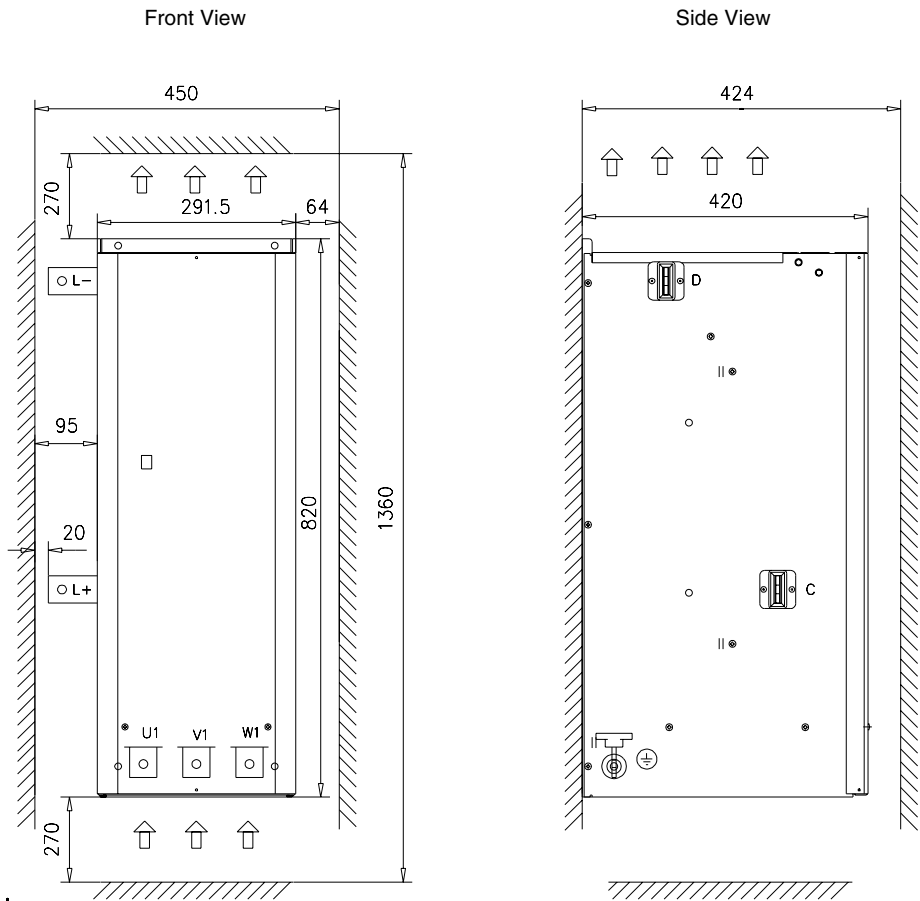


Figure 2-5 Frame B3 supply module dimensions and clearances.



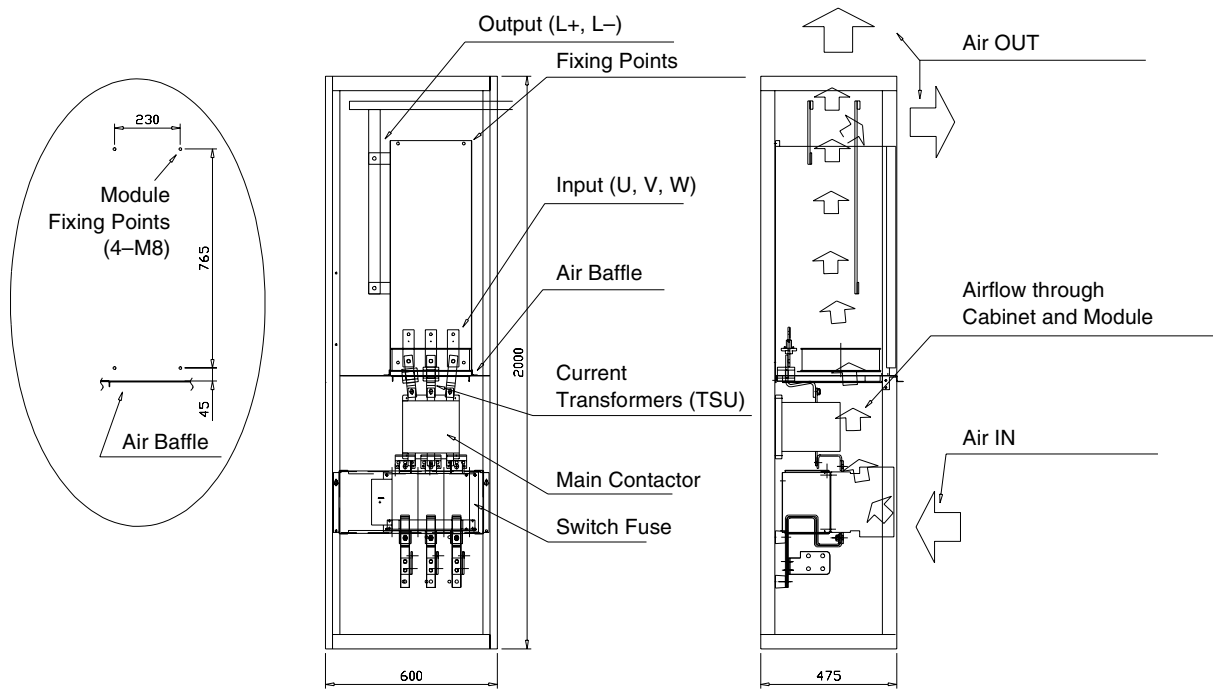


Figure 2-6 Cabinet layout example for Frame B3 supply unit.

MATERIAL: HOT-DIP ZINC COATED STEEL SHEET 2mm  
 EN 10142-DX51D+Z275-N-A-C  
 DIMENSION WITHOUT TOLERANCE DIN 6930-m

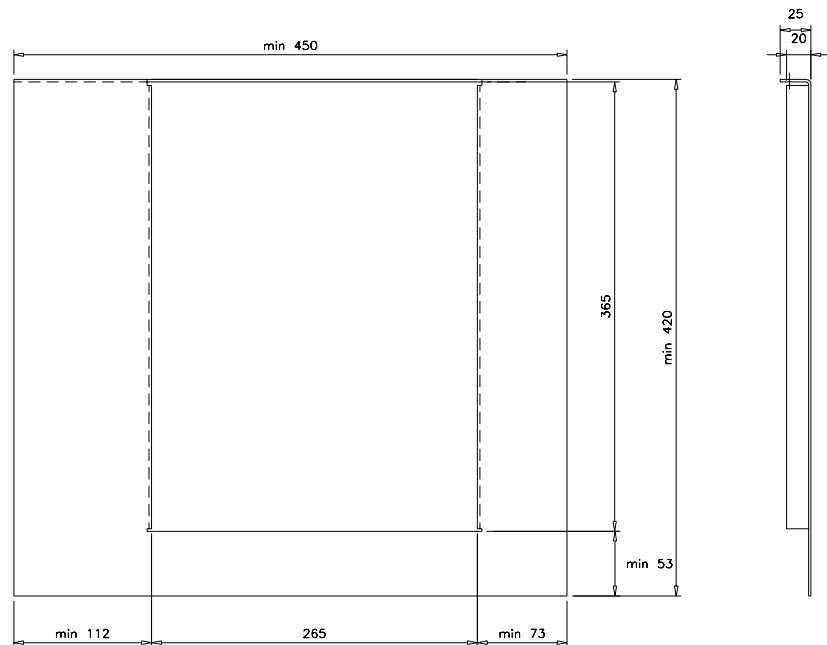


Figure 2-7 Air baffle for Frame B3 supply module.

**Frame B4** Frame B4 supply modules are fixed to the rear wall of the cabinet with two screws, and to the floor of the cabinet with further two. The weight of the module(s) is supported by the cabinet floor. An air baffle must be used to prevent air from circulating inside the cabinet; Figure 2-13 shows a suitable design. The input and output connections on the left side of the module are made using busbars.

These supply modules require an external DC reactor on the DC bus (the L– busbar). The reactor can be installed in a separate cabinet as shown in the layout examples below. The cooling air must be prevented from circumventing the reactor.

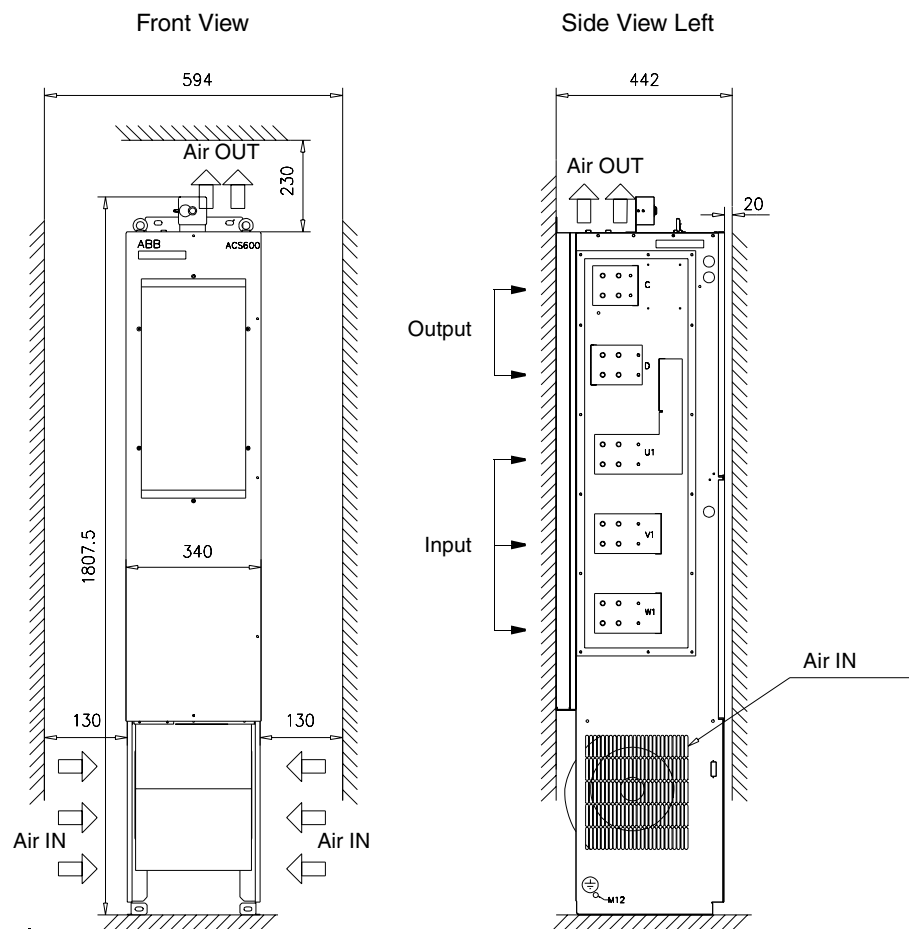


Figure 2-8 Frame B4 supply module dimensions and clearances.

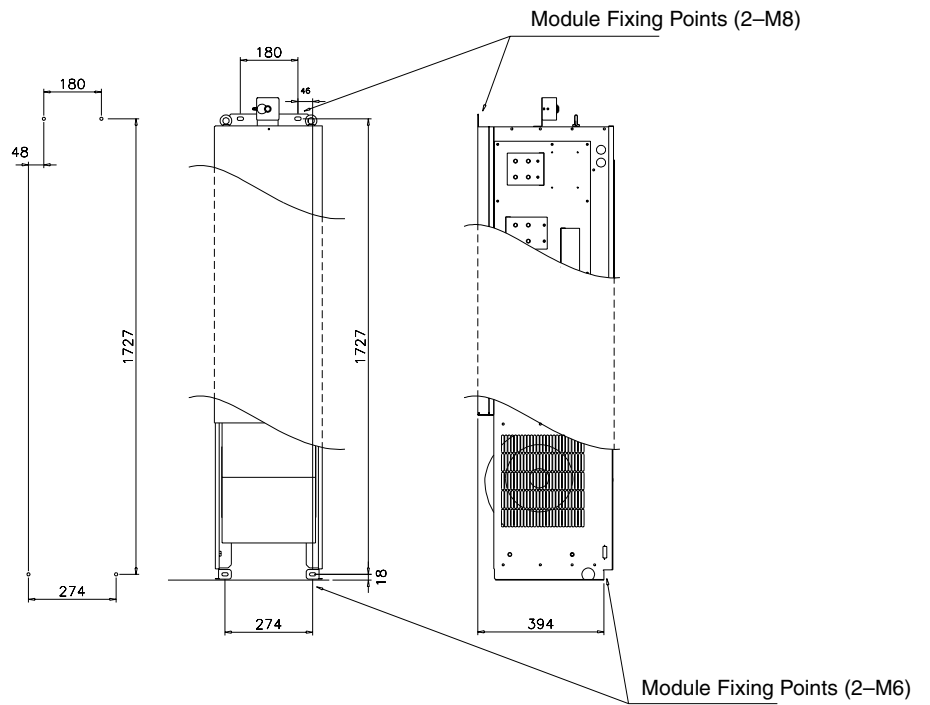


Figure 2-9 Frame B4 supply module fixing points.

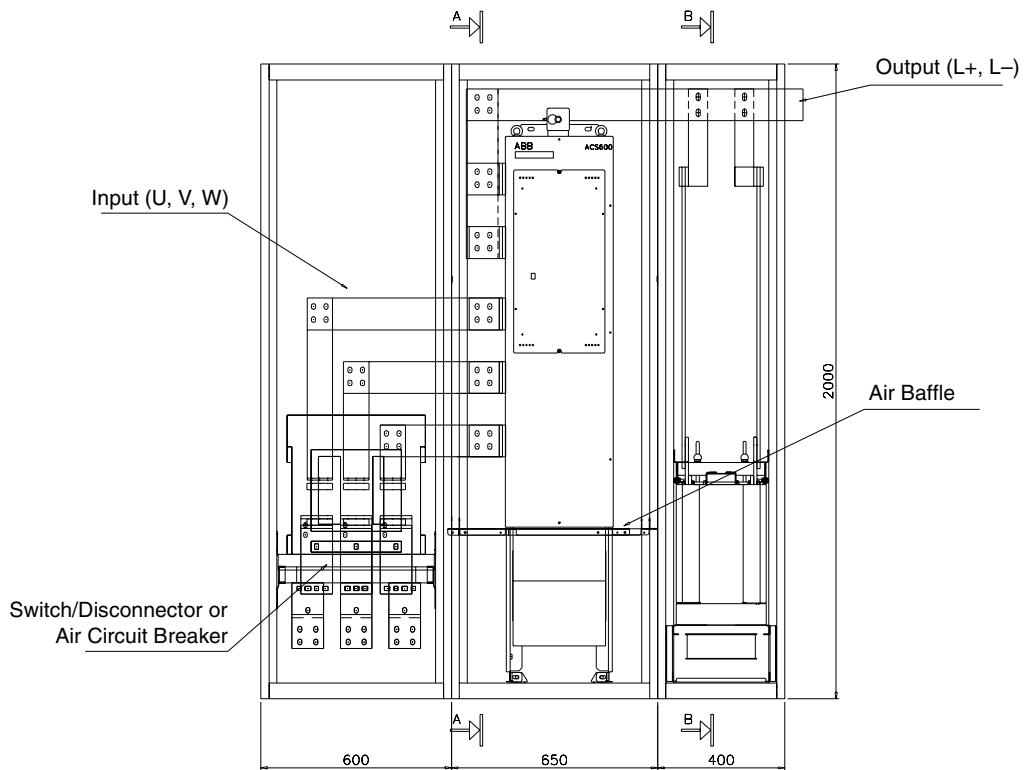


Figure 2-10 Cabinet layout example for Frame B4 diode supply unit (with DC reactor).

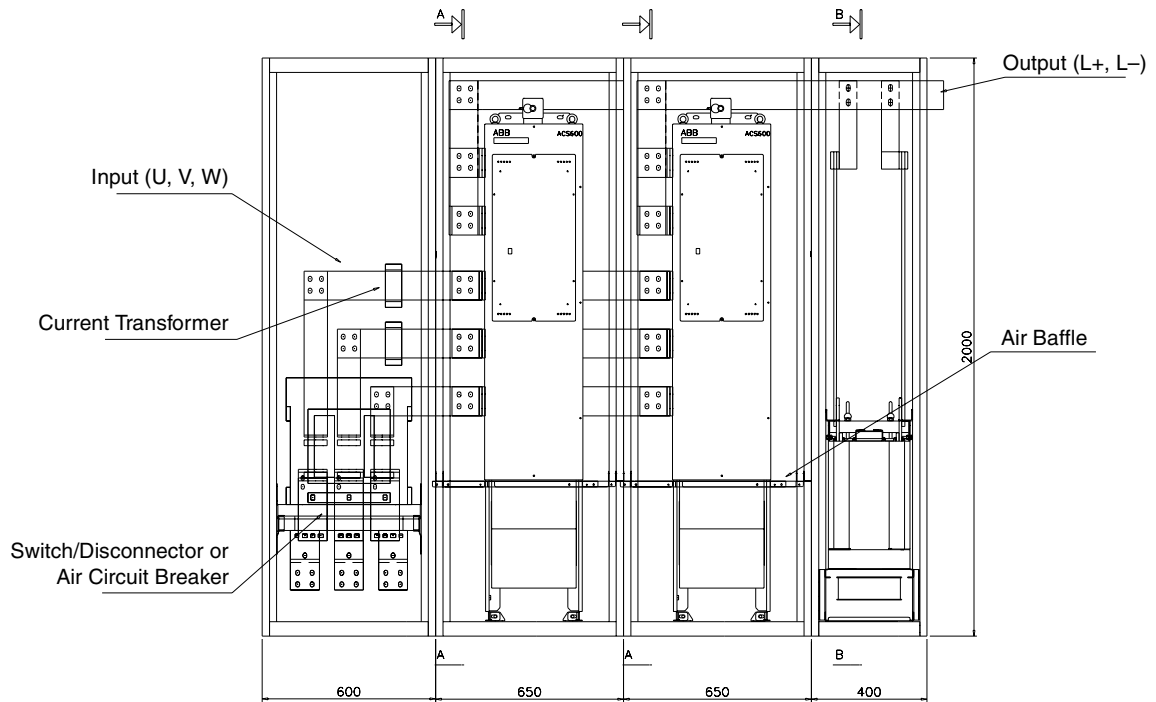


Figure 2-11 Cabinet layout example for Frame B4 thyristor supply unit (with DC reactor).

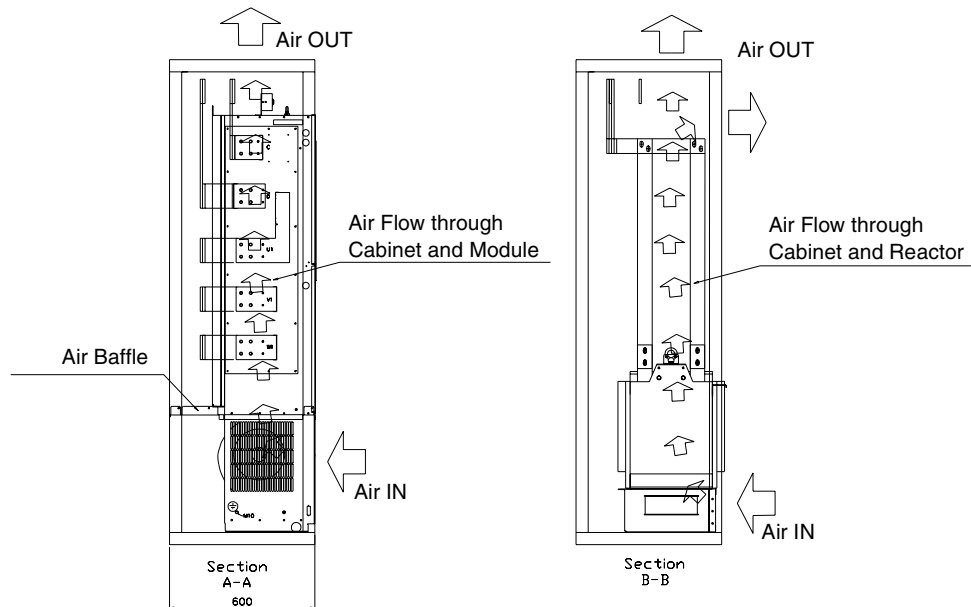


Figure 2-12 Frame B4 supply unit and DC reactor cooling.

MATERIAL: HOT-DIP ZINC COATED STEEL SHEET 1,5mm  
EN 10142-DX51D+Z275-N-A-C  
DIMENSION WITHOUT TOLERANCE DIN 6930-m

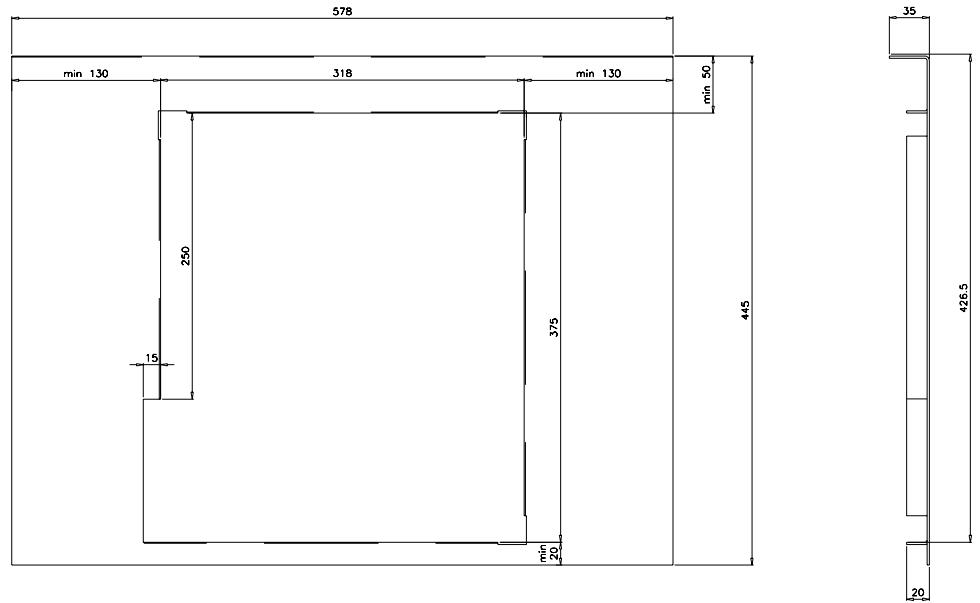


Figure 2-13 Air baffle for Frame B4 supply module.

**Frame B5** Frame B5 supply modules are fixed to the rear wall of the cabinet with two screws, and to the floor of the cabinet with further two. The weight of the module(s) is supported by the cabinet floor. An air baffle must be used to prevent air from circulating inside the cabinet; Figure 2-19 shows a suitable design. The input and output connections on the left side of the module are made using busbars.

These supply modules require an external DC reactor on the DC bus (the L– busbar). The reactor can be installed in a separate cabinet as shown in the layout examples below. The cooling air must be prevented from circumventing the reactor.

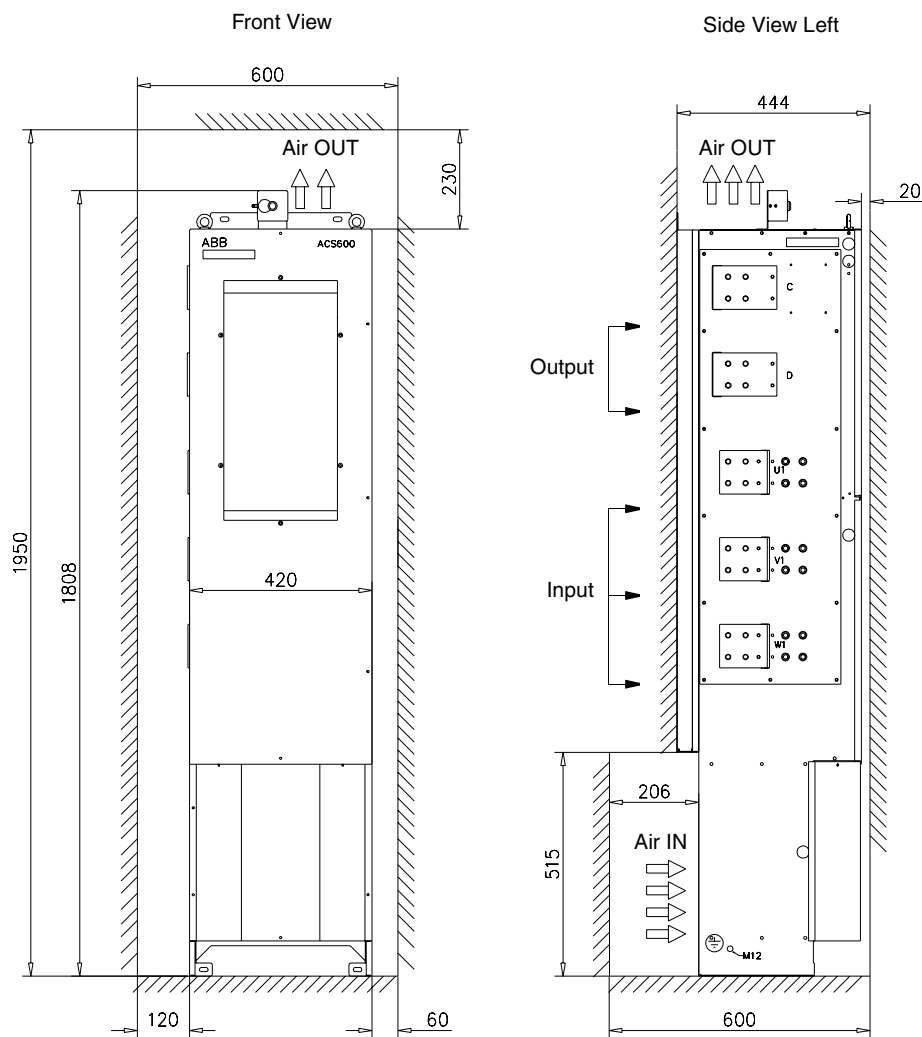


Figure 2-14 Frame B5 supply module dimensions and clearances.

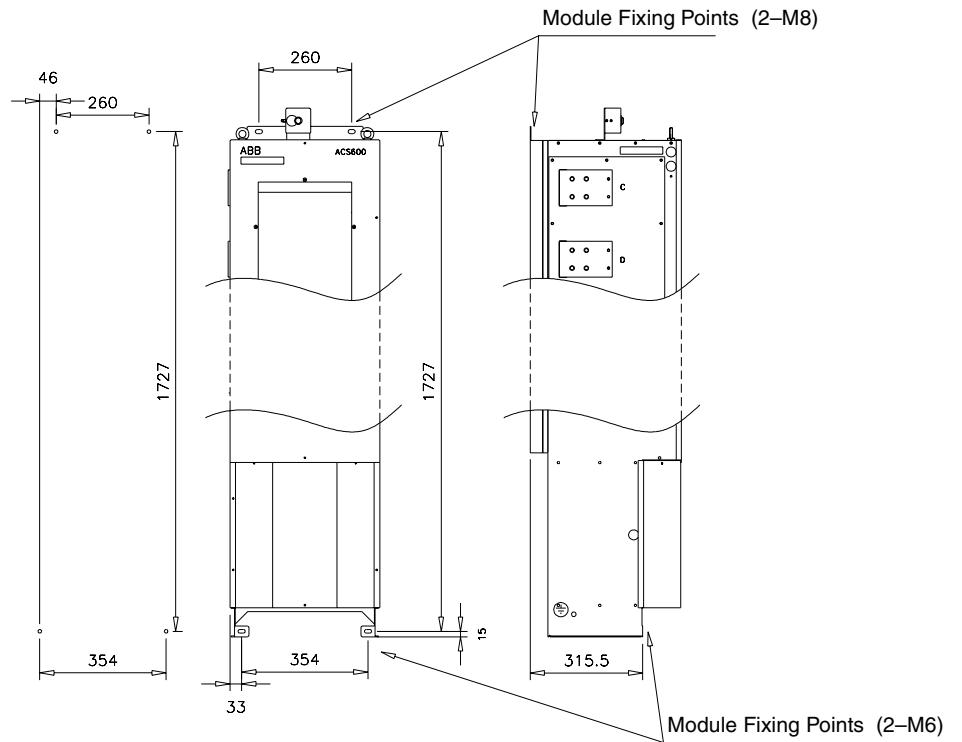


Figure 2-15 Frame B5 supply module fixing points.

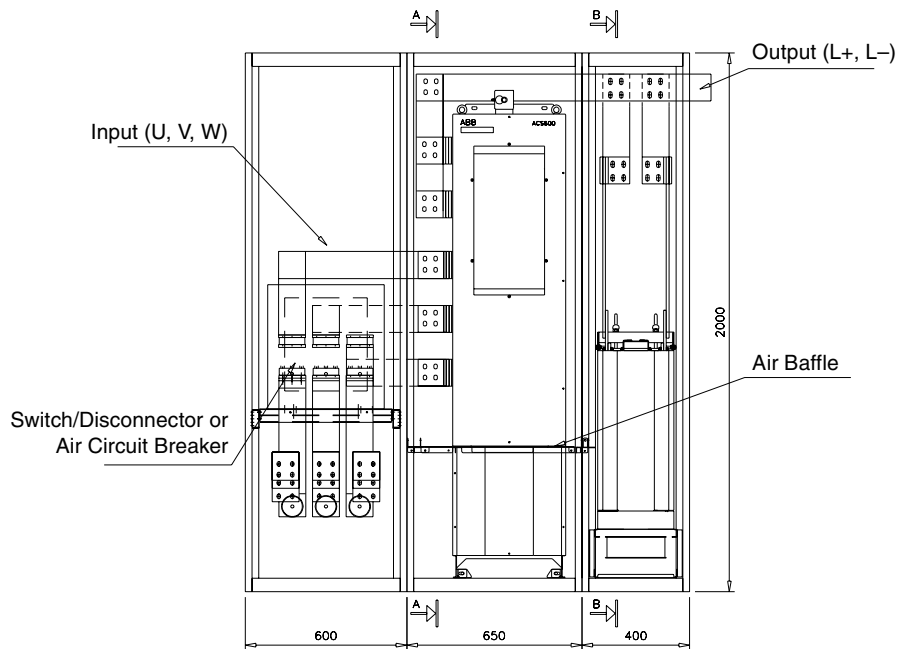


Figure 2-16 Cabinet layout example for Frame B5 diode supply unit (with DC reactor).

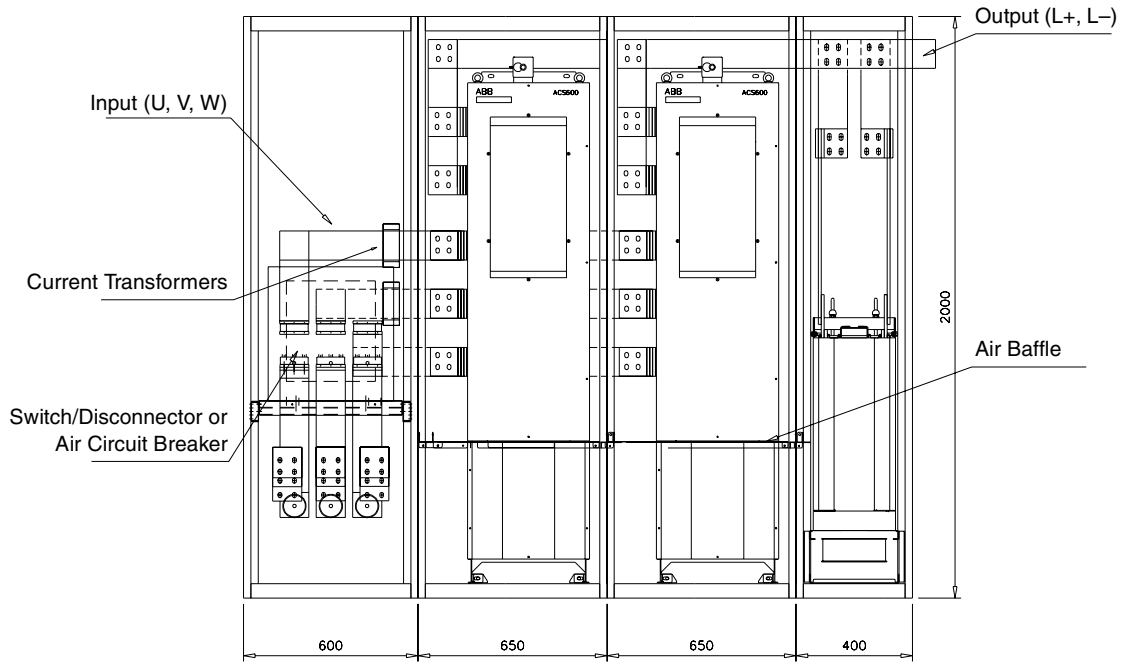


Figure 2-17 Cabinet layout example for Frame B5 thyristor supply unit (with DC reactor).

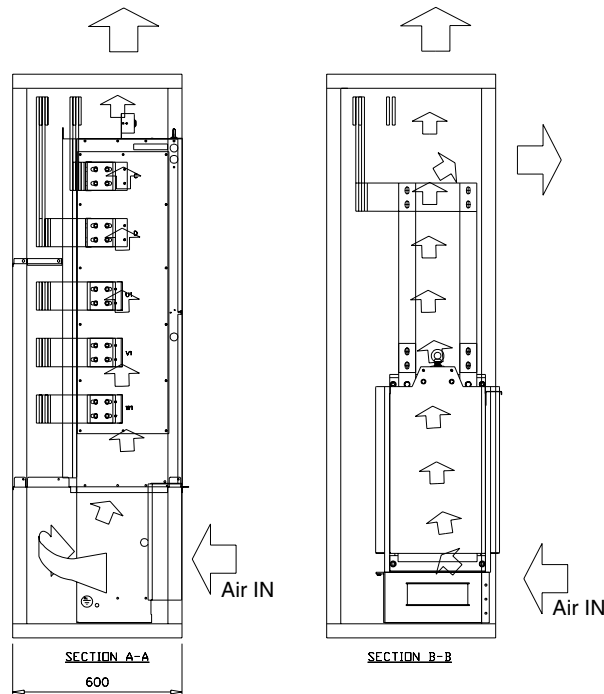


Figure 2-18 Frame B5 supply unit and DC reactor cooling.



MATERIAL: HOT-DIP ZINC COATED STEEL SHEET 1,5mm  
 EN 10142-DXS1D+Z275-N-A-C  
 DIMENSION WITHOUT TOLERANCE DIN 6930-m

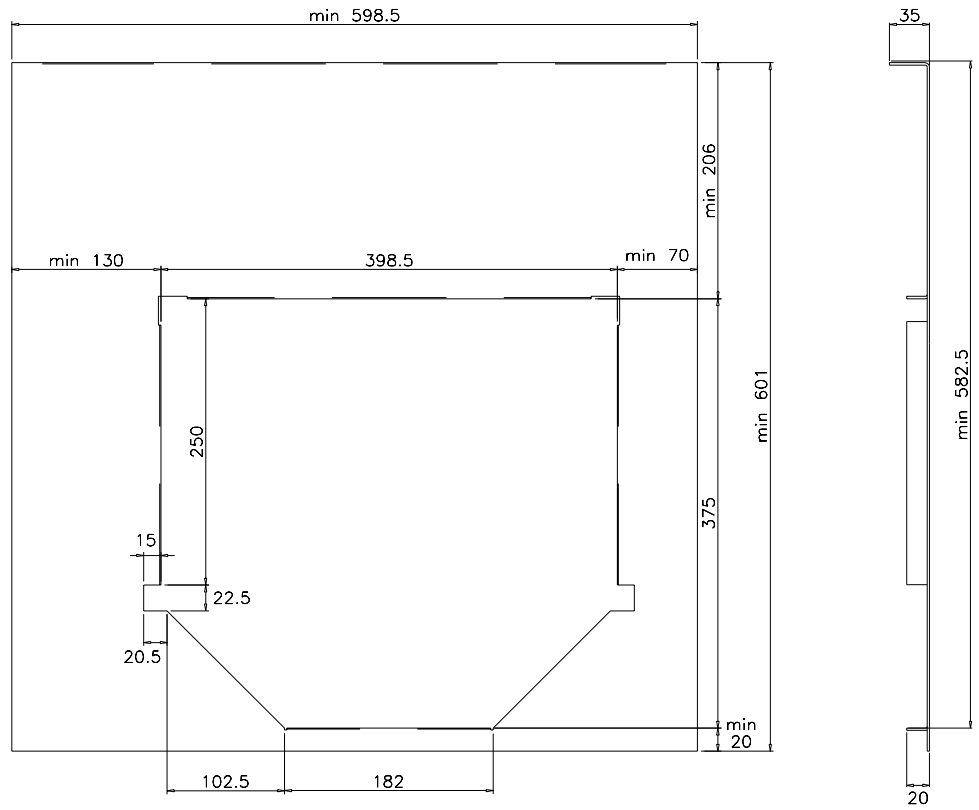


Figure 2-19 Air baffle for Frame B5 supply module.

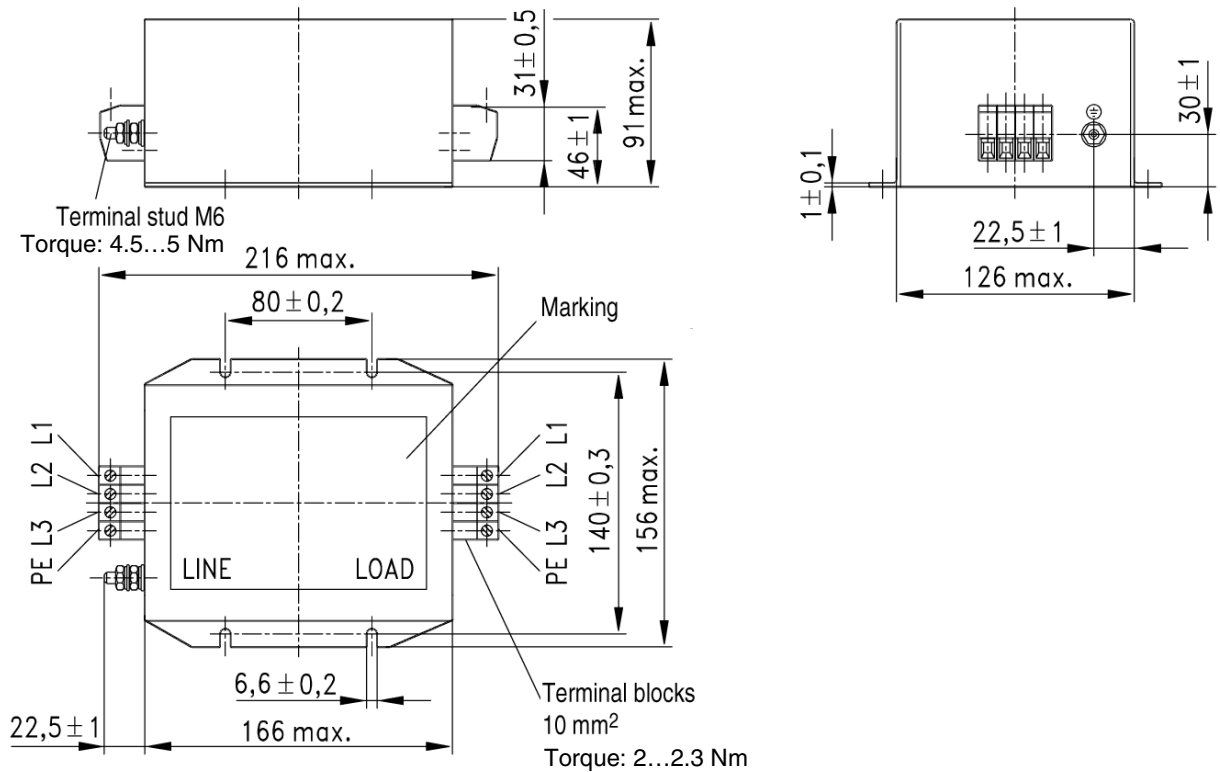
**Frames R6i to R12i (IGBT Supply Modules)** The IGBT supply modules utilise the same hardware (including mounting frames) as inverter modules, so the instructions given under **Drive Units/IGBT Supply Units** (starting page 2-42) apply.

**Line (RFI) Filter**

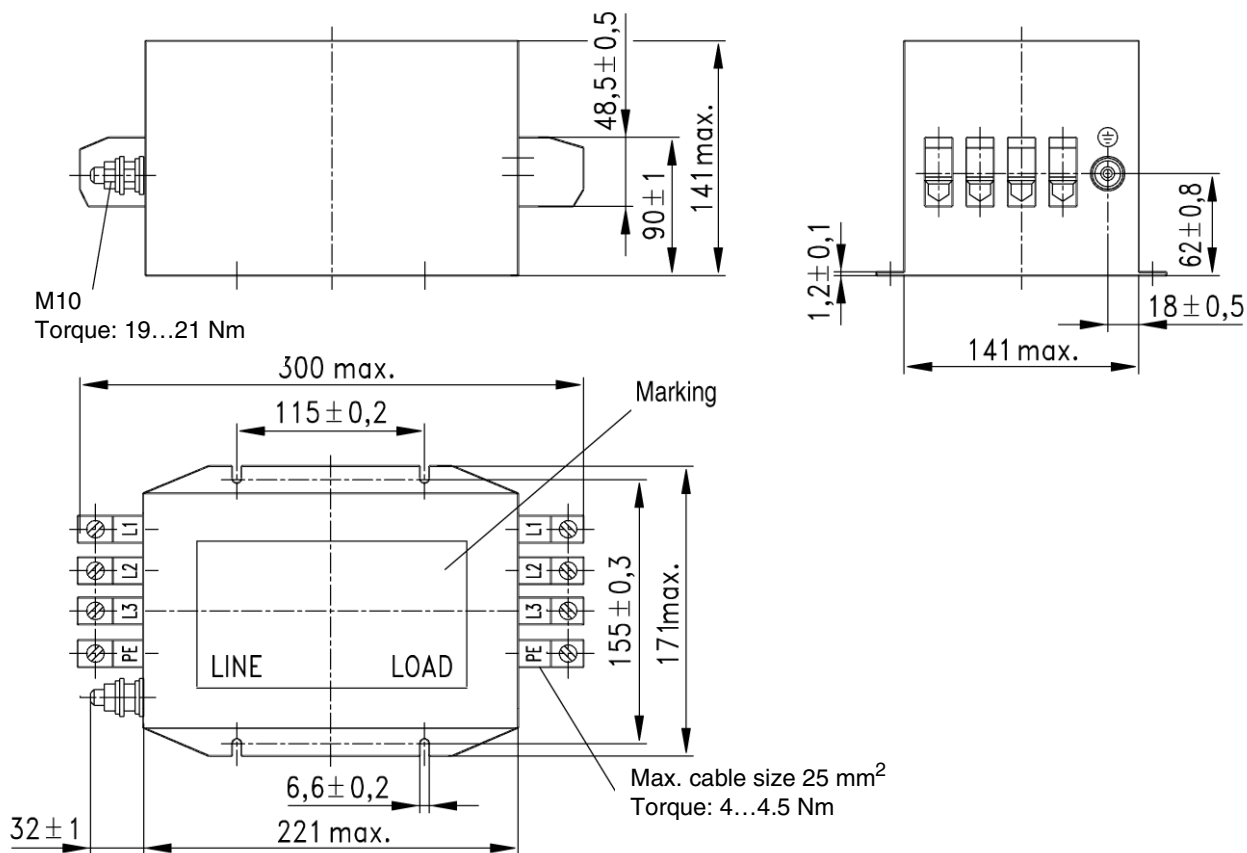
Special attention must be paid to the earthing of the line filter: the filter housing must be properly connected to the cabinet. It is recommended to use the bottom of the filter for the earthing, together with short and wide busbars.

The input cables or busbars between the cable entry and the line filter must be screened with a metal enclosure.

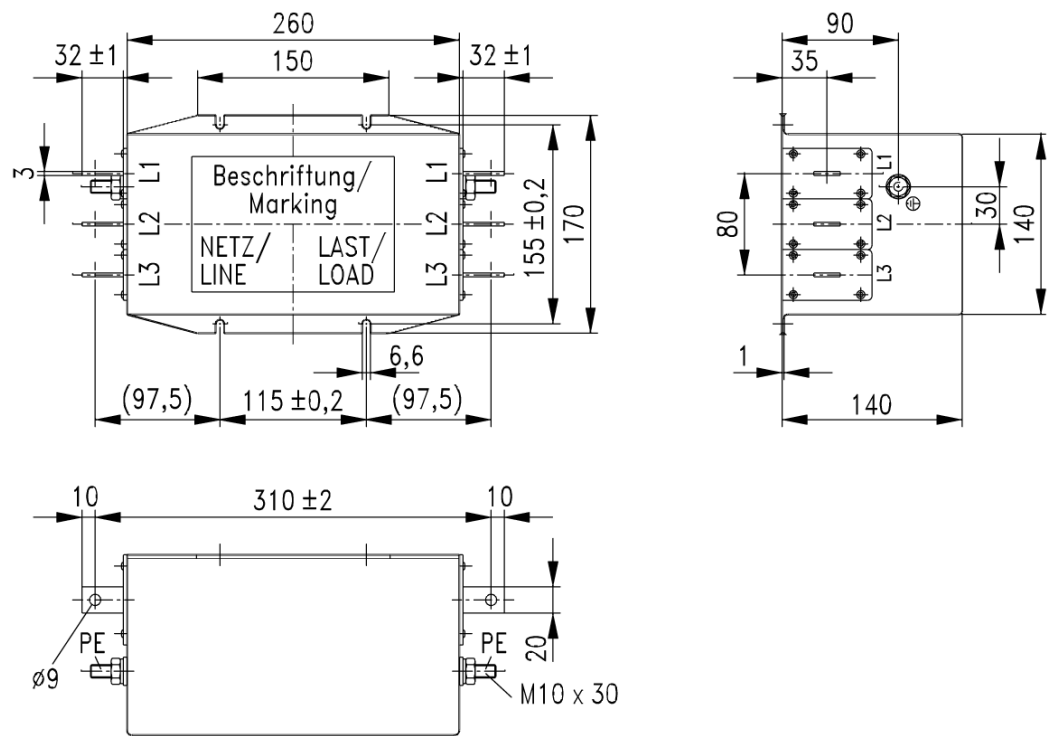
**B84143-A50-R37**



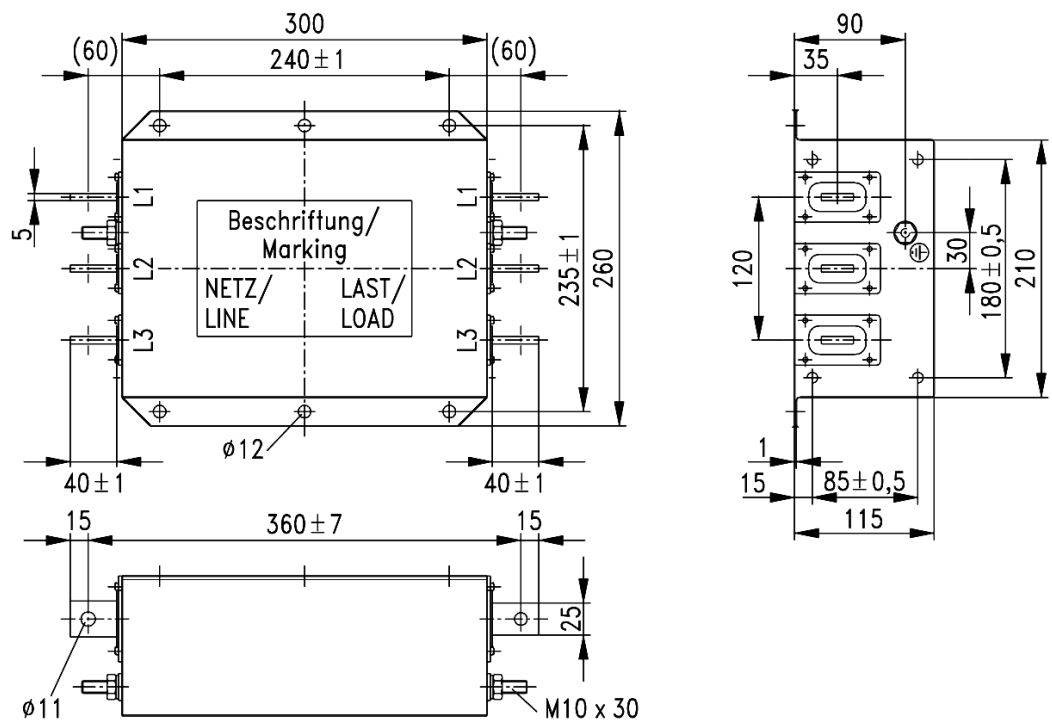
**B84143-A80-R37**



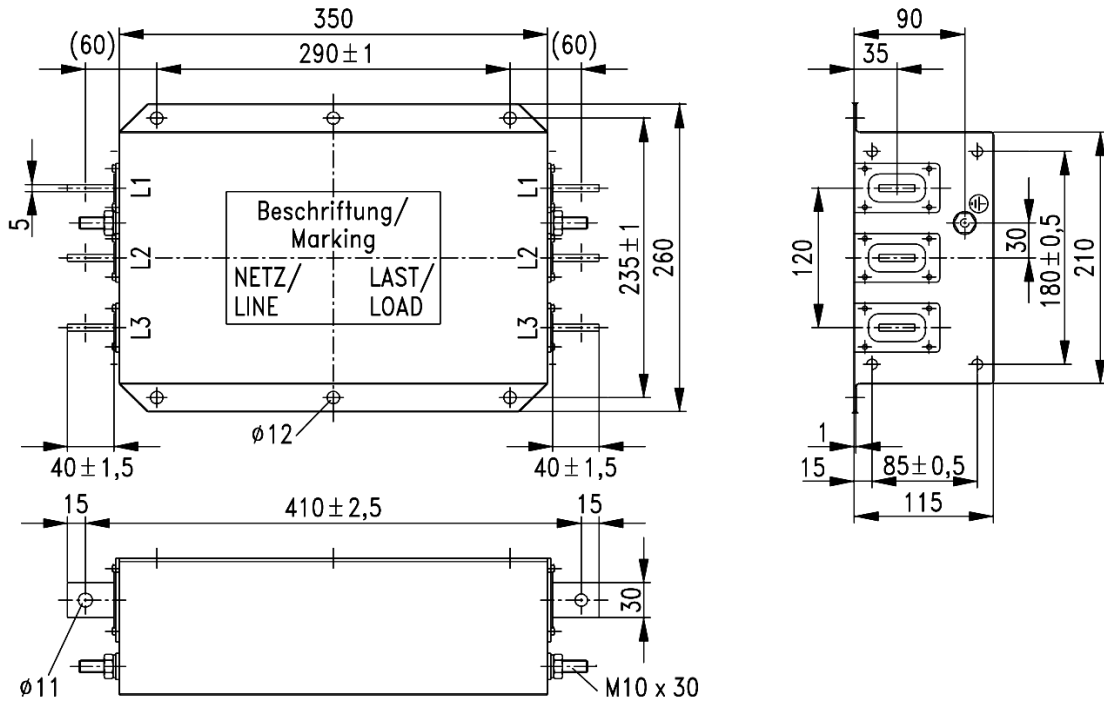
**B84143-B150-S21**



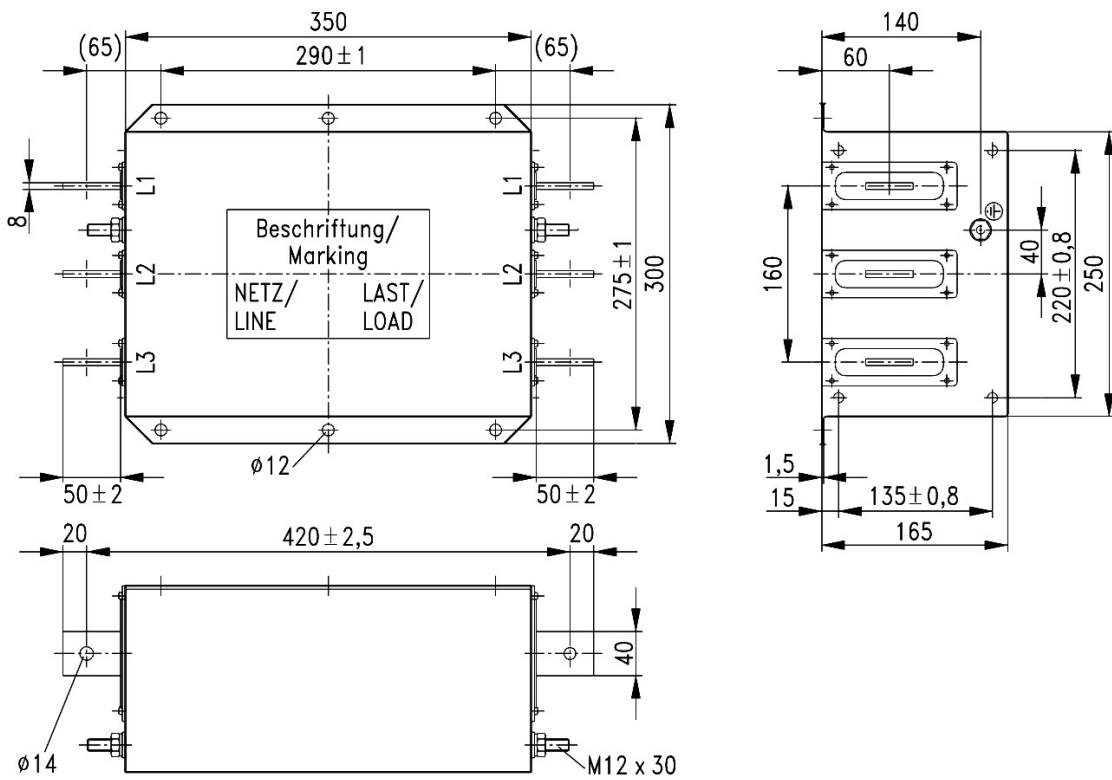
**B84143-B320-S21**



**B84143-B600-S21**



**B84143-B1000-S21**



### LCL Filters

All LCL filters are to be installed on the cubicle floor by the holes shown in the diagrams below. The filter must also be fastened by its top to a crossmember or similar structure.

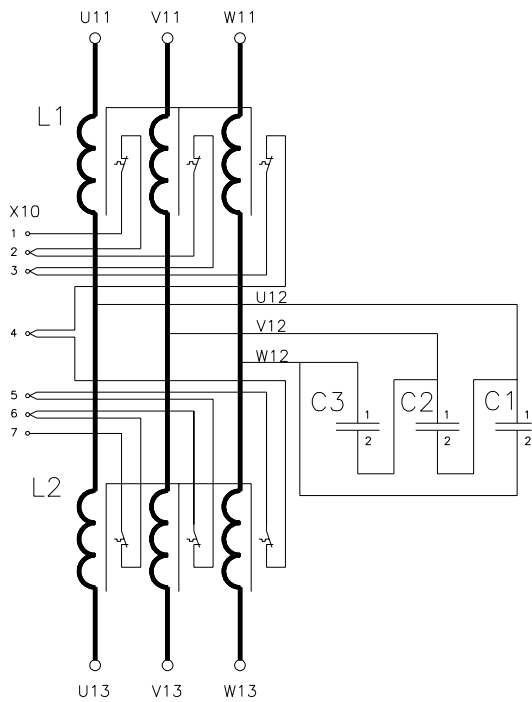
An air baffle must be used with all LCL filter types to prevent air from circulating inside the cubicle. Whenever the filter and the supply module (or other equipment) are installed in one cubicle, the hot air leaving one unit must not be able to enter the intake of the other unit.

The LCL filters have no additional free space requirements in regard to cooling.

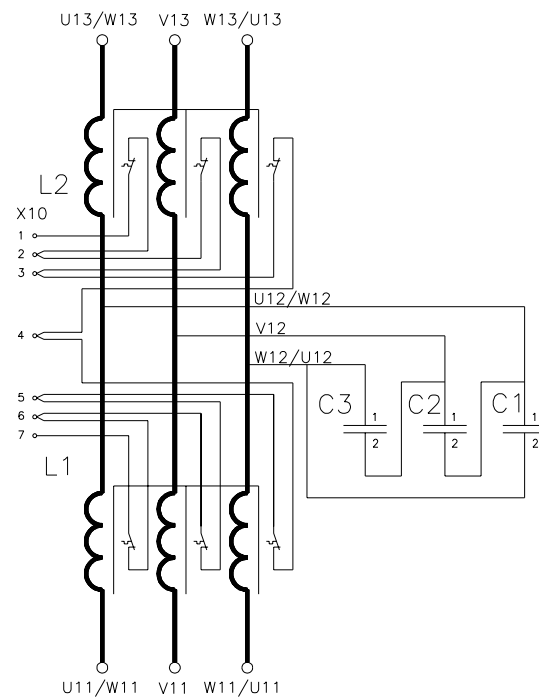
### Internal Circuit Diagrams

ISU\_LCL\_xR7  
ISU\_LCL\_xR8  
ISU\_LCL\_xR9

ISU\_LCL\_xR11  
ISU\_LCL\_xR12



64479997-A



64544748-A

**ISU\_LCL\_xR7**

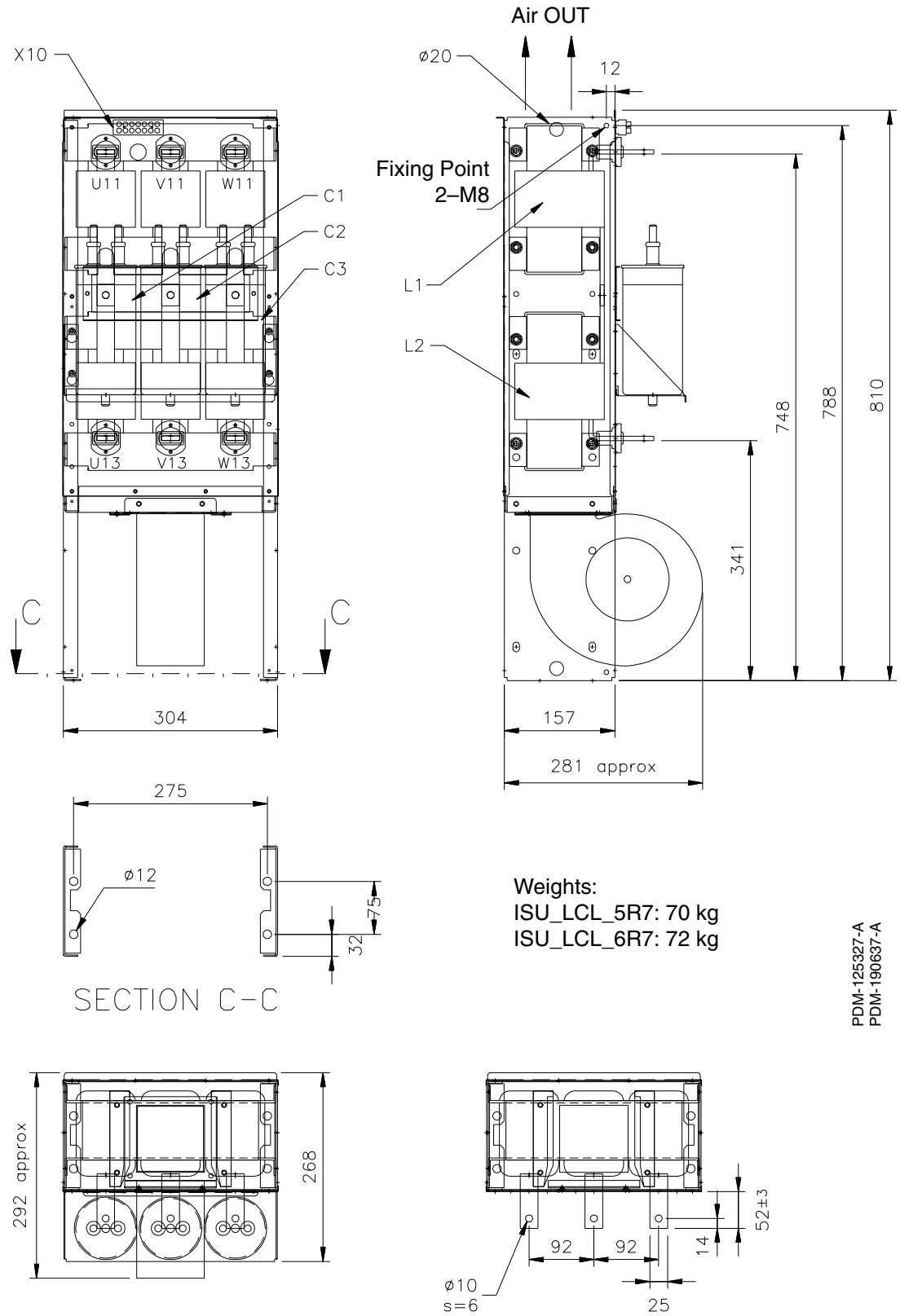


Figure 2-20 ISU\_LCL\_xR7 dimensions, fixing points and connectors.



**ISU\_LCL\_xR8,** The diagram below shows a cabinet layout example with the LCL filter and the IGBT supply module mounted in one cubicle.  
**ISU\_LCL\_xR9**

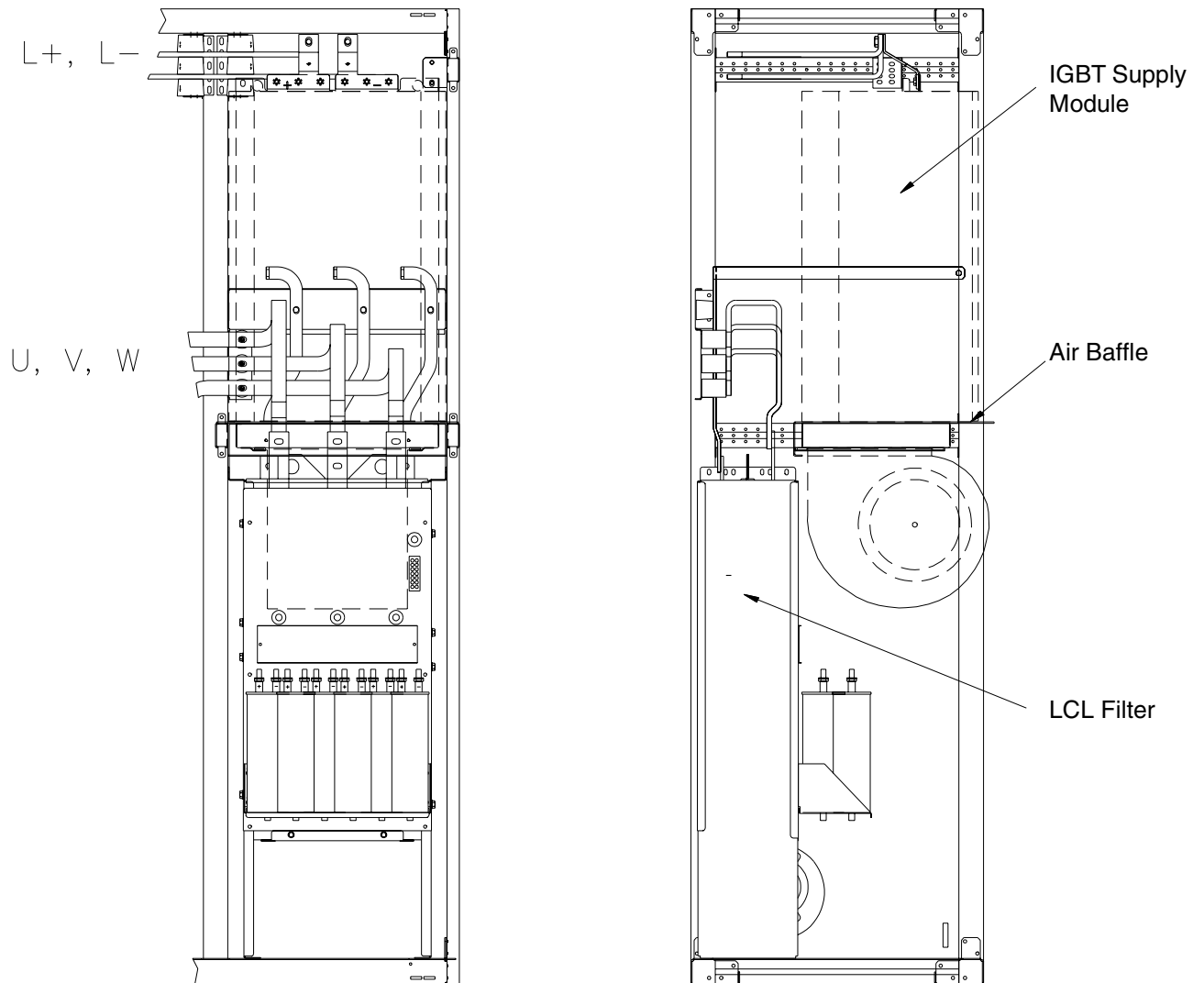


Figure 2-21 Cabinet layout example for ISU\_LCL\_xR8 and ISU\_LCL\_xR9.

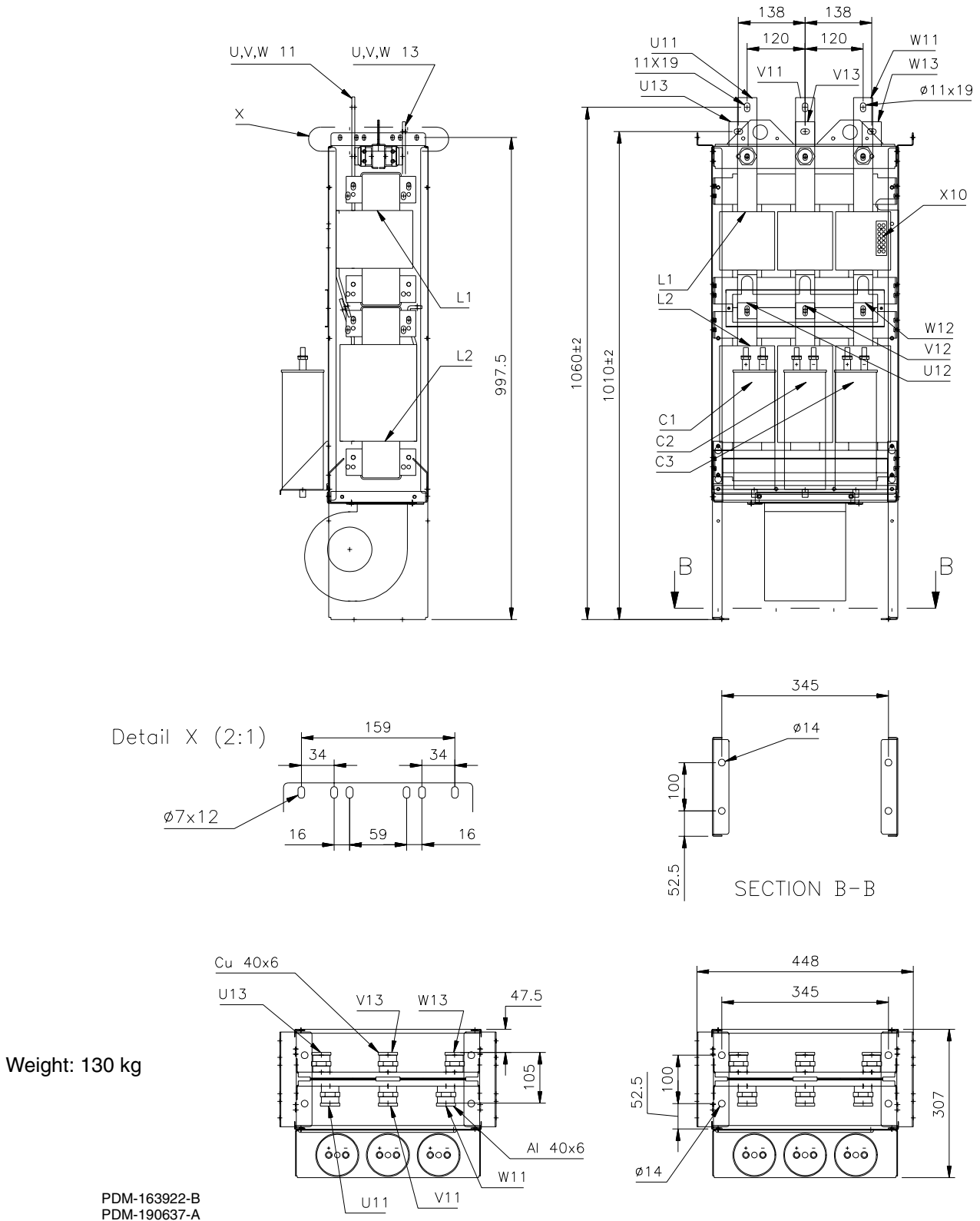


Figure 2-22 ISU\_LCL\_xR8 dimensions, fixing points and connectors.

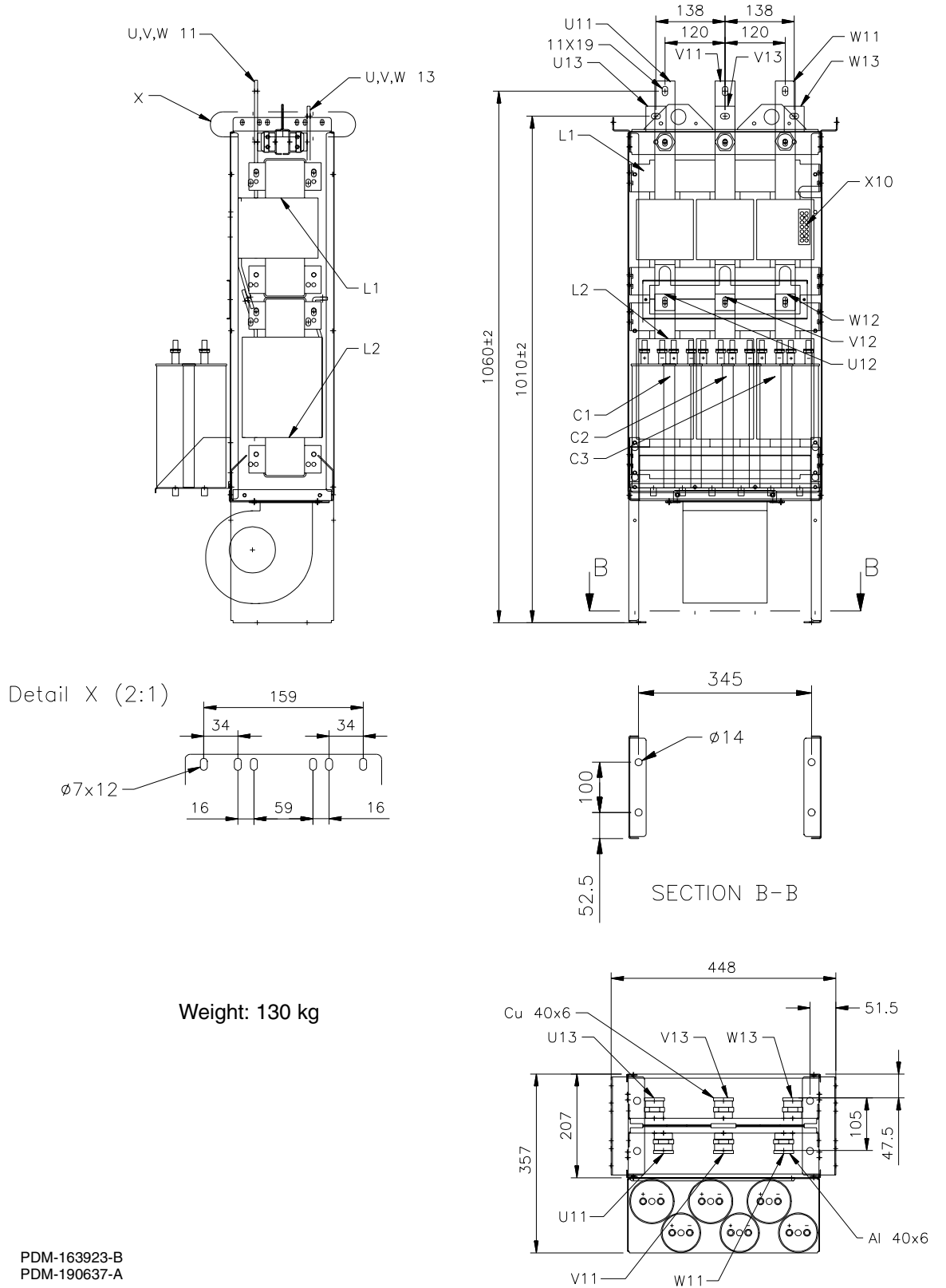


Figure 2-23 ISU\_LCL\_5R9 dimensions, fixing points and connectors.

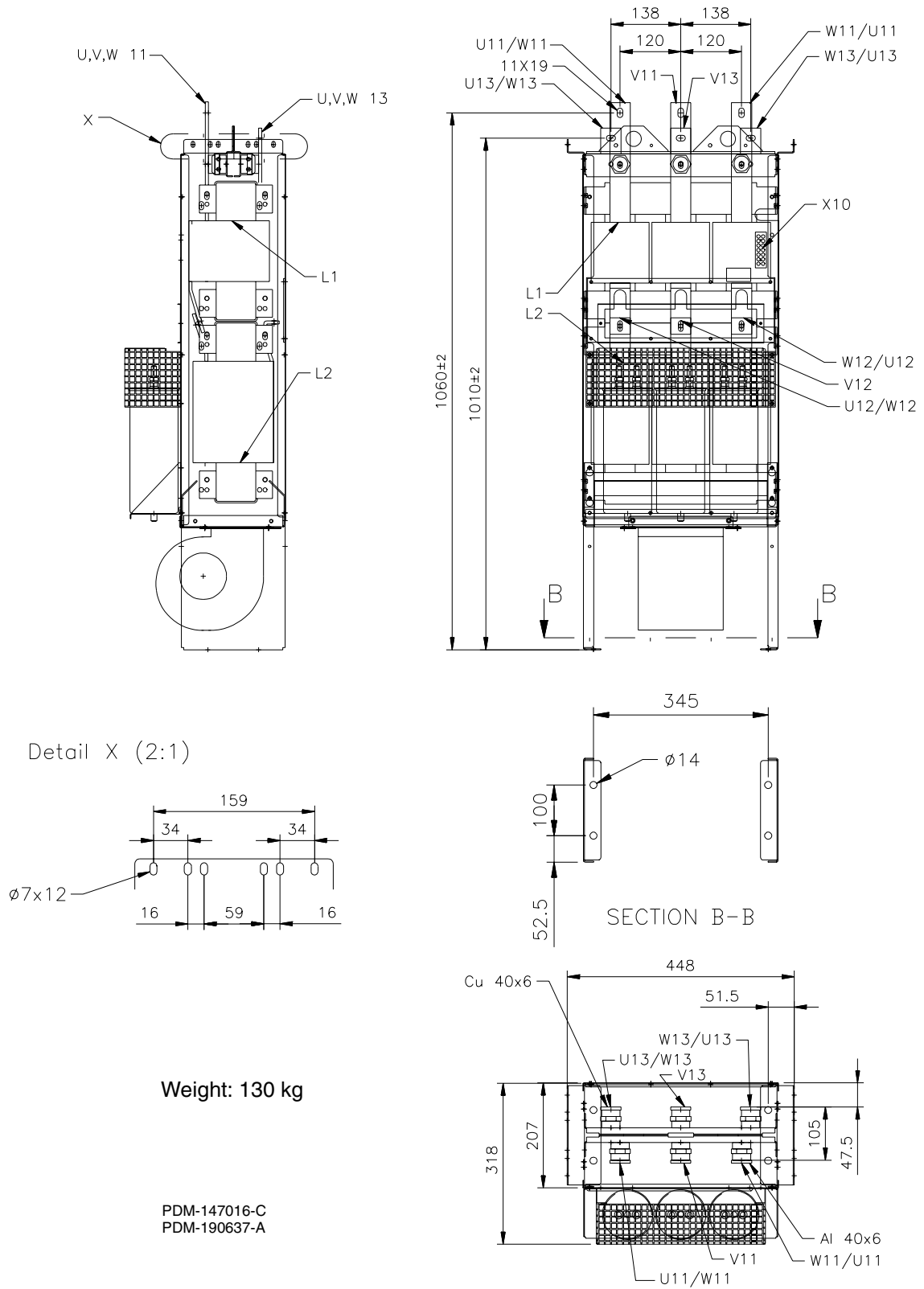
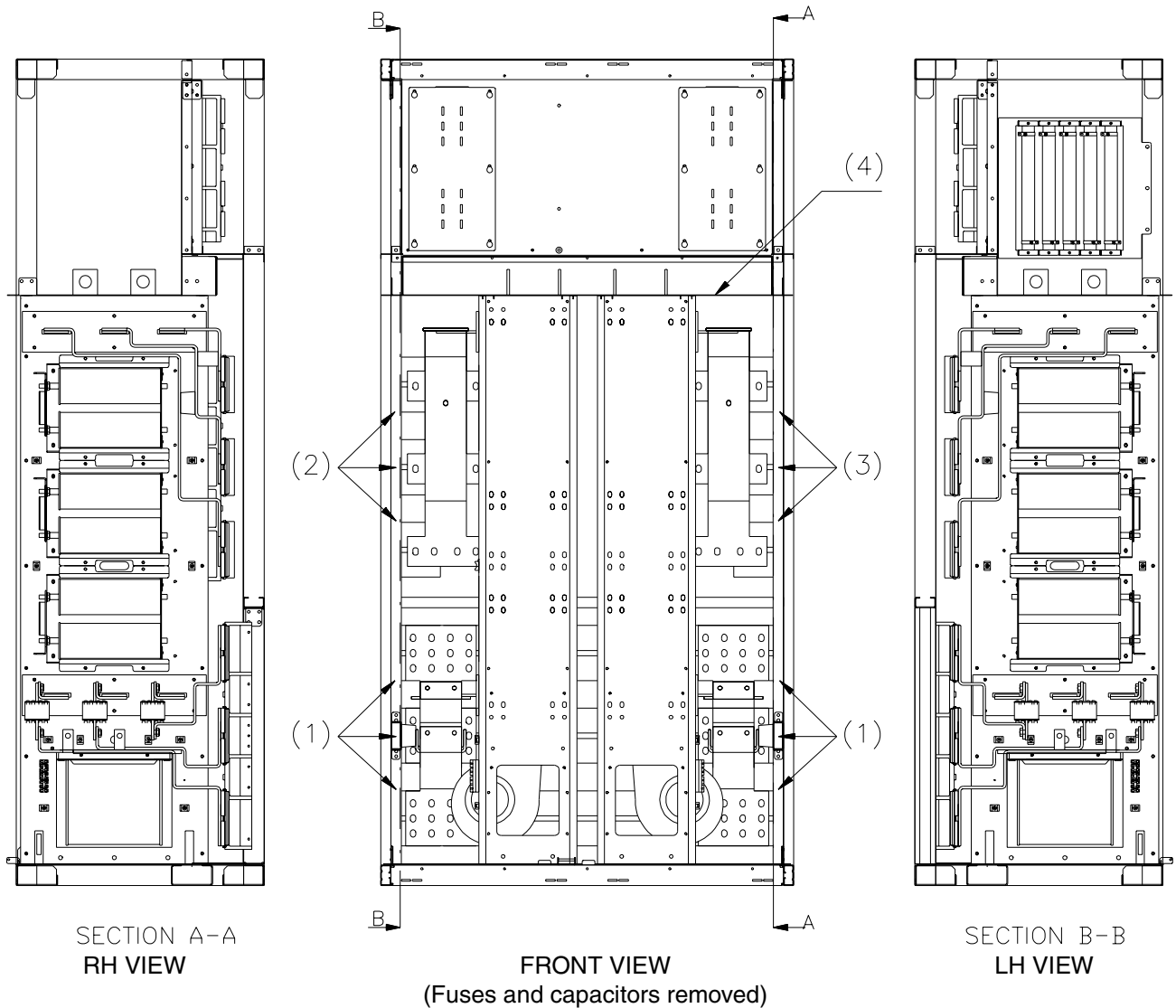


Figure 2-24 ISU\_LCL\_6R9 dimensions, fixing points and connectors.

**ISU\_LCL\_xR11,  
ISU\_LCL\_xR12**

For parallel-connected IGBT supply modules (Frames 2xR11, 2xR12, etc.) two filters can be mounted back-to-back in one cubicle as shown below.

The capacitor assemblies of the filters can easily be rotated 180 degrees e.g. for easier wiring or extra space in the desired direction. In the example, the capacitors of the right-hand filter have been rotated in order to free some space for the output busbars.



- (1) Input (from left or right)
- (2) Output to LH supply module
- (3) Output to RH supply module
- (4) Air baffle

**Note:** Capacitor assemblies of RH filter have been turned round 180 degrees.

*Figure 2-25 Cabinet layout example for two ISU\_LCL\_xR11 or ISU\_LCL\_xR12 filters.*

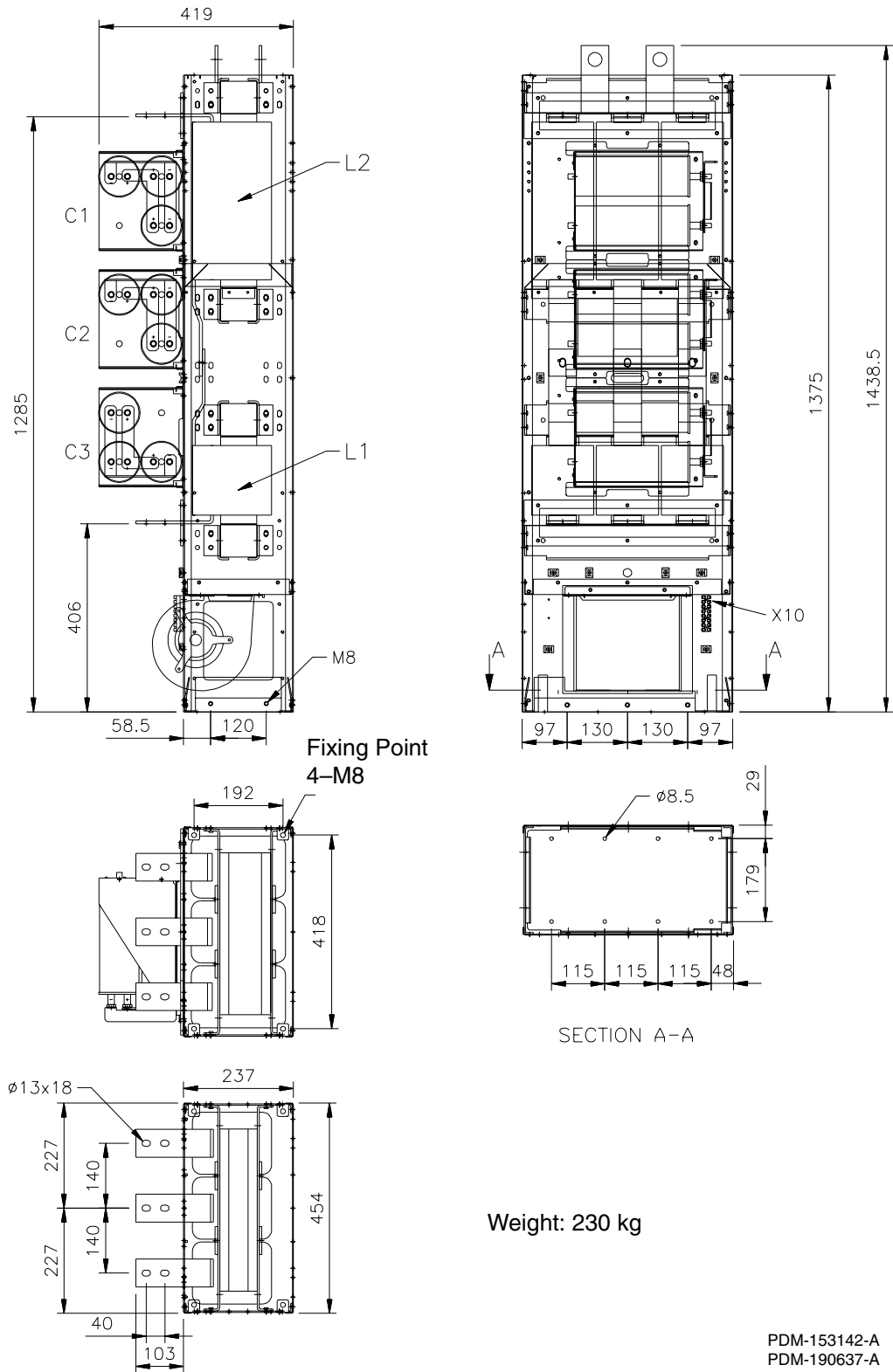


Figure 2-26 ISU\_LCL\_5R11 dimensions, fixing points and connectors.

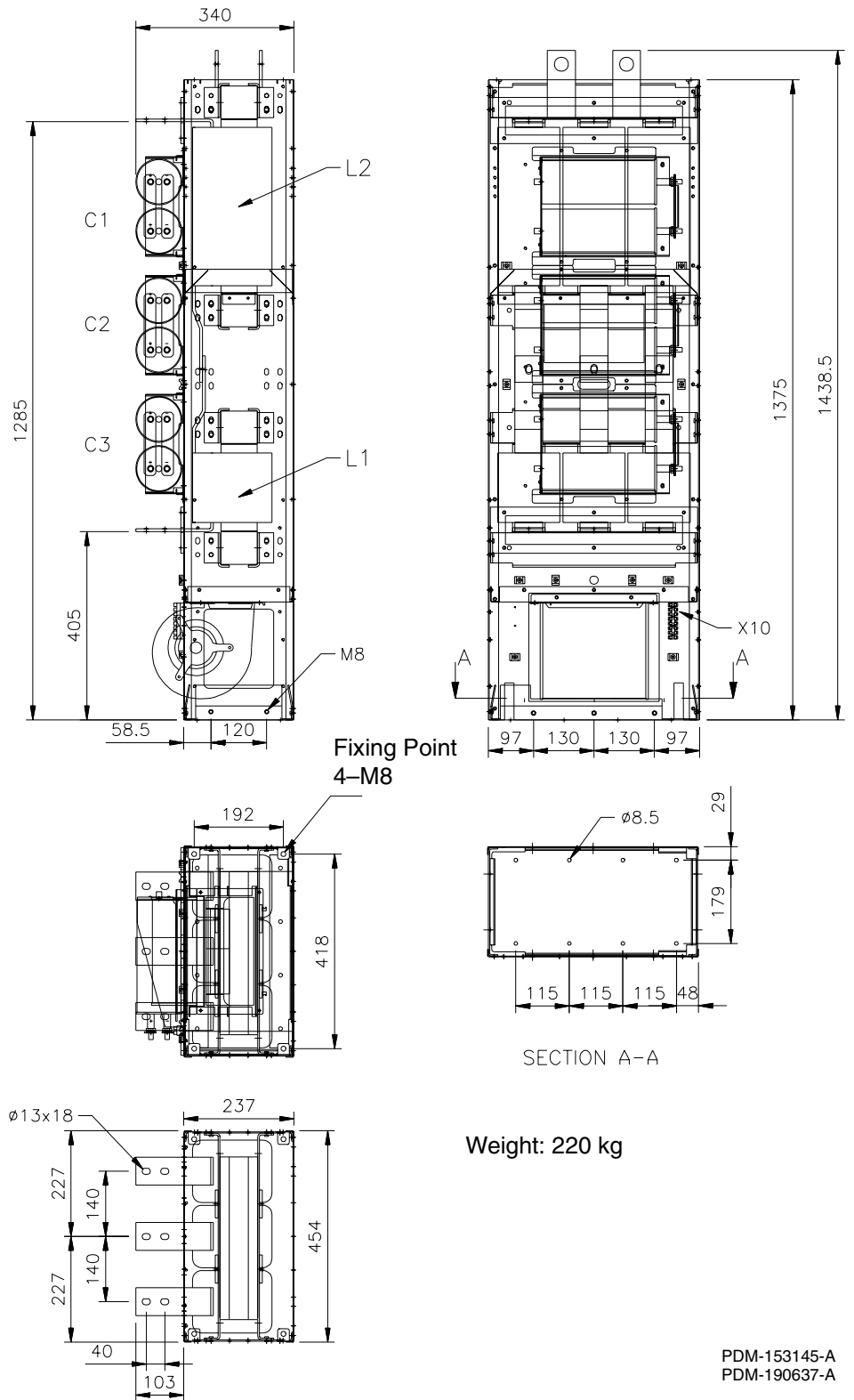


Figure 2-27 ISU\_LCL\_6R11 dimensions, fixing points and connectors.

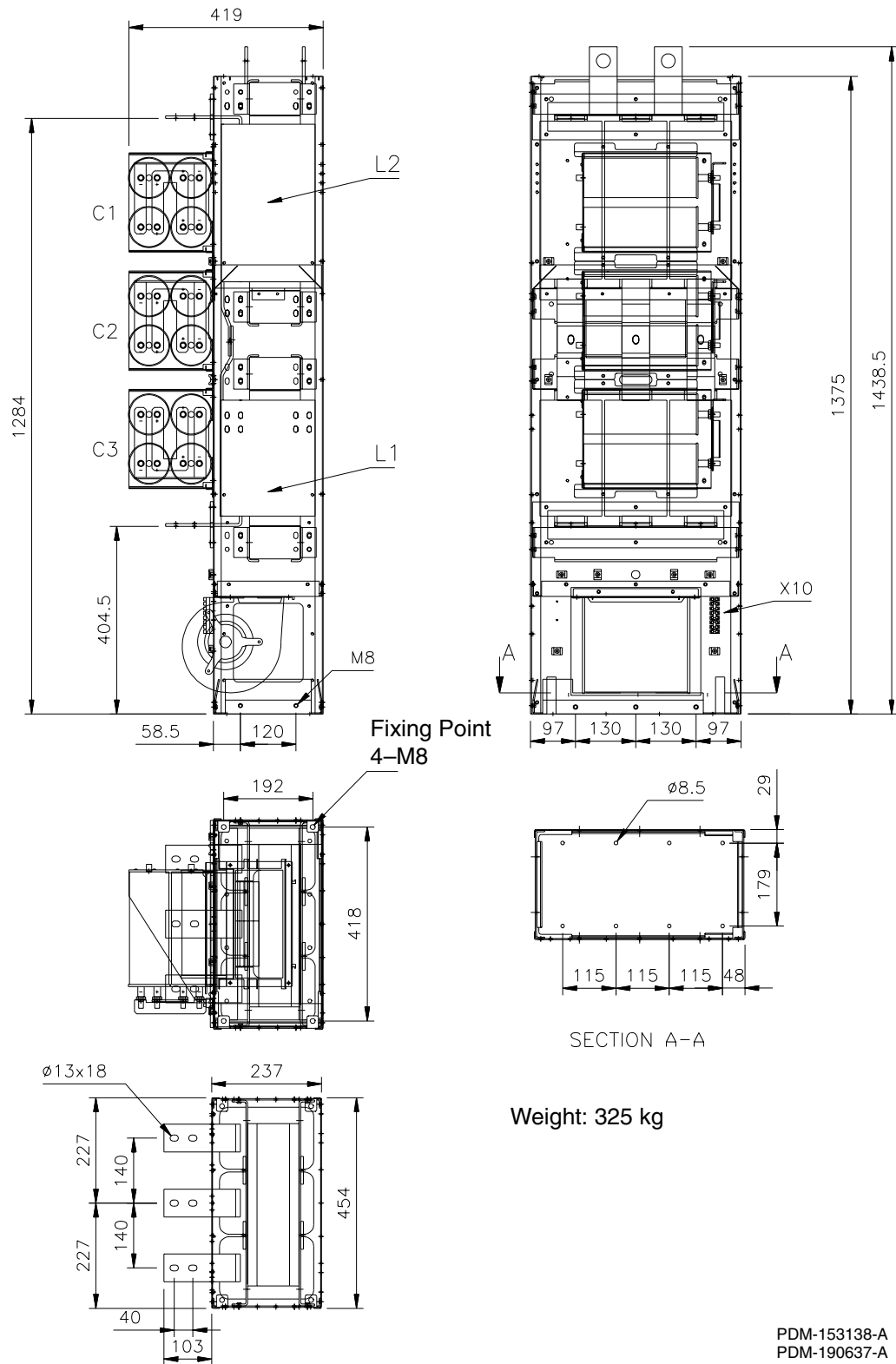


Figure 2-28 ISU\_LCL\_5R12 dimensions, fixing points and connectors.



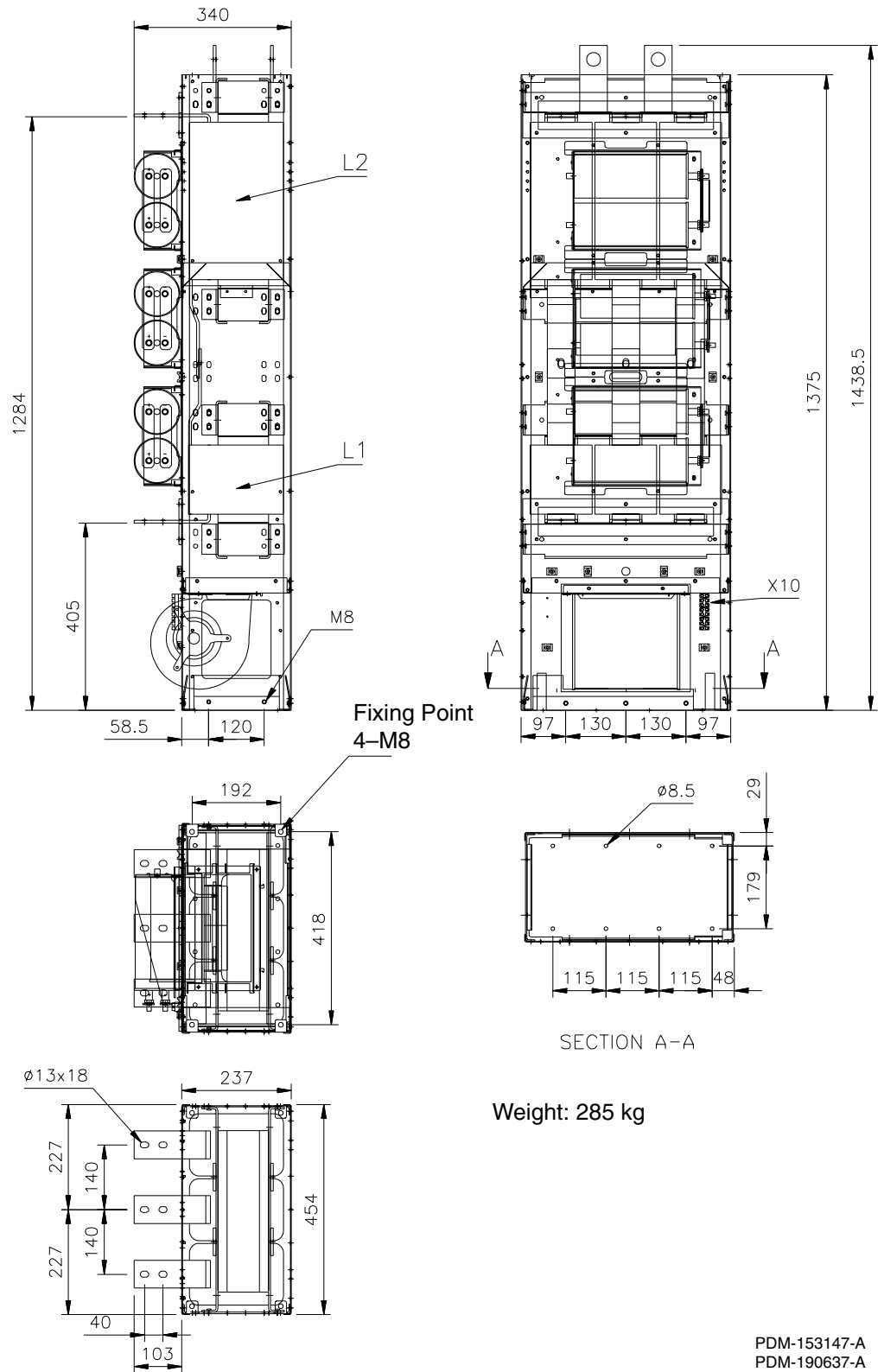
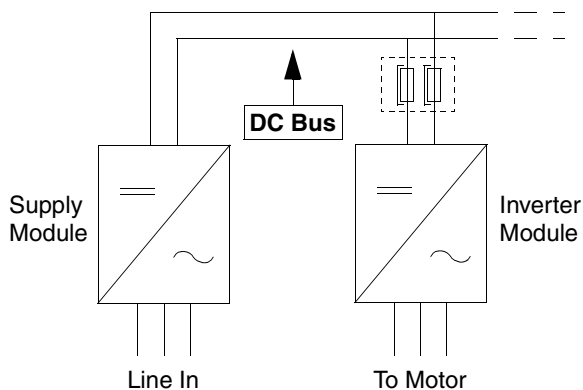


Figure 2-29 ISU\_LCL\_6R12 dimensions, fixing points and connectors.

**DC Bus**

The table below shows recommended cross-sections for internal DC busbars for different currents. The dimensions given are valid for cabinet installation and natural convection, and based on measurements on a standard ACS 600 MultiDrive.



Material	Current [A]	DC Bus Size (per leg)	Arrangement (see DC bus arrangement examples.)
Aluminium	1370	2 × (30 × 10)	A
	2100	2 × (60 × 10)	B
	3500	4 × (60 × 10)	C
Copper	1990	2 × (30 × 10)	A
	3000	2 × (60 × 10)	B
	4300	4 × (60 × 10)	C

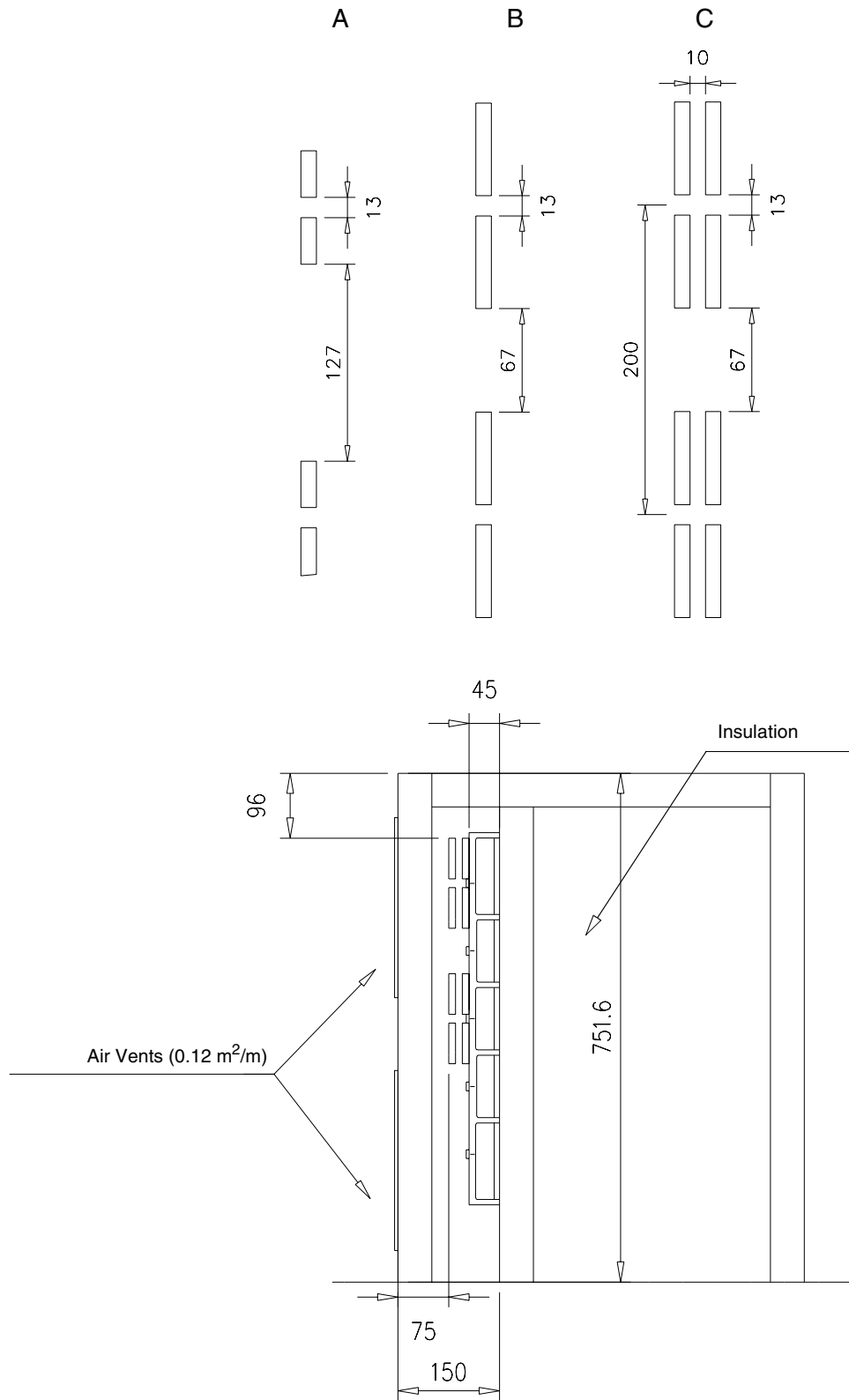


Figure 2-30 DC bus arrangement examples.

**Drive Units/  
IGBT Supply Units**

**Note:** The data in this section applies to both IGBT supply modules and inverter modules unless otherwise noted.

**Cooling Conditions**

The tables below show the general cooling conditions and recommended effective air inlet/outlet areas for the drive unit or IGBT supply unit cabinets.

Frame	Voltage [V]	Max. Incoming Air Temperature [°C]	Max. Air Temperature Rise [°C]	Min. Air Flow [m³/h]	Pressure Difference over Module [Pa]	Max. Pressure Drop of Cabinet [Pa]	Cooling Fan Type
R2i	400/500	50	2	40	45	N/A	Internal
	690		–				
R3i	400/500	50	3	60	45	N/A	Internal
	690		4				
R4i	400/500	50	4	70	30	N/A	Internal
	500		8	100			
R5i	400/500	50	4	260	75	N/A	Internal
	690		7				
R6i	400/500	40	24	480	116	67	G2E140-AI51-ABB
	690		14				G2E140-AI32-ABB
R7i	400/500	40	18	480	116	67	G2E140-AI51-ABB
	690		21				G2E140-AI32-ABB
R8i	400/500	40	8	1550	222	74	D4E225-CC01-39
	690						D4E225-CC07-37
R9i	400/500	40	11	1550	222	74	D4E225-CC01-39
	690		9				D4E225-CC07-37
R10i	400/500	40	5	3100	210	86	2 × D4E225-CC01-39
	690						2 × D4E225-CC01-39
*R11i	400/500	40	7	3100	210	86	2 × D4E225-CC01-39
	690		5				2 × D4E225-CC01-39
*R12i	400/500	40	8	4650	220	76	3 × D4E225-CC01-39
	690						3 × D4E225-CC01-39

\*For units consisting of parallel-connected modules (2×R11i, 2×R12i, 4×R11i, 4×R12i), the data is per one module.

*Effective Air Inlet/Outlet  
Areas*

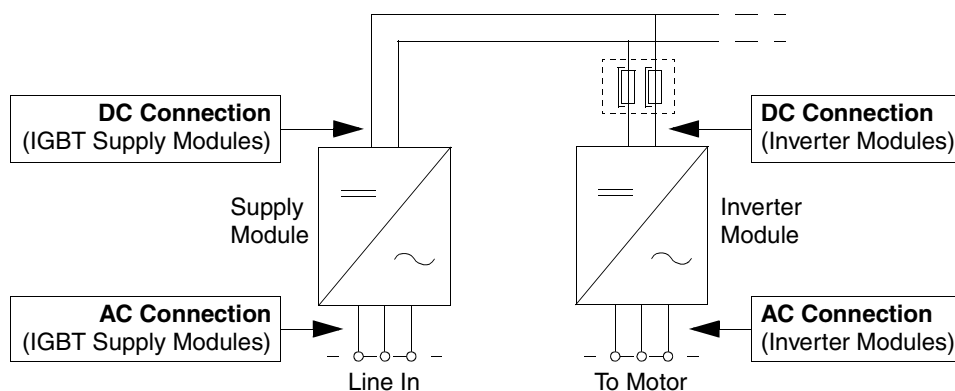
<b>Module</b>	<b>Effective Air Inlet Area [m<sup>2</sup>]</b>	<b>Effective Air Outlet Area [m<sup>2</sup>]</b>	<b>Filter Material</b>
R2i...R5i (up to 3 modules)	0.065	0.065	Air-Tex G-150
R2i...R5i (4...6 modules)	0.109	0.109	
R6i, R7i (1 module)	0.065	0.065	
R6i, R7i (2 modules)	0.109	0.109	
R8i, R9i	0.217	0.109	
R10i, *R11i	0.347	0.195	
*R12i	0.521	0.304	

\*For units consisting of parallel-connected modules (2xR11i, 2xR12i, 4xR11i, 4xR12i), the data is per one module.

**Inverter Module/IGBT  
Supply Module  
Power Connections**

The table below shows the power connection types and recommended cable/busbar cross-sectional areas for the inverter/IGBT supply modules.

**Note:** The table is valid for the cables/busbars inside the drive cabinet line-up only. External cables (eg. motor cables) must be dimensioned separately. For information, refer to the subsequent section (*Motor Cable Dimensioning*), and *Grounding and cabling of the drive system* (3AFY 61201998 [English]).



Module		DC Connection			AC Connection		
		Connection Type		Cross-section (per leg)	Connection Type		Cross-section (per leg)
Frame	Type	Cable Lug	Connection Hole for Busbar		Cable Lug	Connection Hole for Busbar	
400 V							
R2i	ACN 634 0005 3	–	–	6 mm <sup>2</sup>	–	–	6 mm <sup>2</sup>
	ACN 634 0006 3	–	–	6 mm <sup>2</sup>	–	–	6 mm <sup>2</sup>
	ACN 634 0009 3	–	–	6 mm <sup>2</sup>	–	–	6 mm <sup>2</sup>
R3i	ACN 634 0011 3	–	–	6 mm <sup>2</sup>	–	–	10 mm <sup>2</sup>
	ACN 634 0016 3	–	–	6 mm <sup>2</sup>	–	–	10 mm <sup>2</sup>
R4i	ACN 634 0020 3	–	–	10 mm <sup>2</sup>	–	–	16 mm <sup>2</sup>
	ACN 634 0025 3	–	–	10 mm <sup>2</sup>	–	–	16 mm <sup>2</sup>
R5i	ACN 634 0030 3	–	–	35 mm <sup>2</sup>	–	–	35 mm <sup>2</sup>
	ACN 634 0040 3	–	–	35 mm <sup>2</sup>	–	–	35 mm <sup>2</sup>
	ACN 634 0050 3	–	–	35 mm <sup>2</sup>	–	–	35 mm <sup>2</sup>
(Continued)							

Module		DC Connection			AC Connection		
		Connection Type		Cross-section (per leg)	Connection Type		Cross-section (per leg)
Frame	Type	Cable Lug	Connection Hole for Busbar		Cable Lug	Connection Hole for Busbar	
<i>400 V (Continued)</i>							
R6i	ACN 634 0060 3	70–10	–	70 mm <sup>2</sup>	70–10	–	70 mm <sup>2</sup>
	ACN 634 0070 3	70–10	–	70 mm <sup>2</sup>	70–10	–	70 mm <sup>2</sup>
R7i	ACN 634 0100 3	120–10	–	120 mm <sup>2</sup>	120–10	–	95 mm <sup>2</sup>
	ACN 634 0120 3	120–10	–	120 mm <sup>2</sup>	120–10	–	95 mm <sup>2</sup>
R8i	ACN 634 0185 3	–	Ø10 mm (M8)	4 × 40 mm	–	Ø11 mm (M8)	6 × 25 mm
	ACN 634 0225 3	–	Ø10 mm (M8)	4 × 40 mm	–	Ø11 mm (M8)	6 × 25 mm
	ACN 634 0265 3	–	Ø10 mm (M8)	4 × 40 mm	–	Ø11 mm (M8)	6 × 25 mm
R9i	ACN 634 0335 3	–	Ø10 mm (M8)	4 × 40 mm	–	Ø11 mm (M8)	6 × 25 mm
	ACN 634 0405 3	–	Ø10 mm (M8)	4 × 40 mm	–	Ø11 mm (M8)	6 × 25 mm
R10i	ACN 634 0505 3	–	Ø10 mm (M8)	2 × (4 × 40 mm)*	–	Ø11 mm (M8)	10 × 80 mm** 6 × 25 mm***
R11i	ACN 634 0635 3	–	Ø10 mm (M8)	2 × (4 × 40 mm)*	–	Ø11 mm (M8)	10 × 80 mm** 6 × 25 mm***
	ACN 634 0755 3	–	Ø10 mm (M8)	2 × (4 × 40 mm)*	–	Ø11 mm (M8)	10 × 80 mm** 6 × 25 mm***
R12i	ACN 634 0935 3	–	Ø10 mm (M8)	3 × (4 × 40 mm)*	–	Ø11 mm (M8)	3 × 284 mm** 3 × (6 × 25) mm***
	ACN 634 1125 3	–	Ø10 mm (M8)	3 × (4 × 40 mm)*	–	Ø11 mm (M8)	3 × 284 mm** 3 × (6 × 25) mm***
<i>500 V</i>							
R2i	ACN 634 0006 5	–	–	6 mm <sup>2</sup>	–	–	6 mm <sup>2</sup>
	ACN 634 0009 5	–	–	6 mm <sup>2</sup>	–	–	6 mm <sup>2</sup>
	ACN 634 0011 5	–	–	6 mm <sup>2</sup>	–	–	6 mm <sup>2</sup>
R3i	ACN 634 0016 5	–	–	6 mm <sup>2</sup>	–	–	10 mm <sup>2</sup>
	ACN 634 0020 5	–	–	6 mm <sup>2</sup>	–	–	10 mm <sup>2</sup>
R4i	ACN 634 0025 5	–	–	10 mm <sup>2</sup>	–	–	16 mm <sup>2</sup>
	ACN 634 0030 5	–	–	10 mm <sup>2</sup>	–	–	16 mm <sup>2</sup>
R5i	ACN 634 0040 5	–	–	35 mm <sup>2</sup>	–	–	35 mm <sup>2</sup>
	ACN 634 0050 5	–	–	35 mm <sup>2</sup>	–	–	35 mm <sup>2</sup>
	ACN 634 0060 5	–	–	35 mm <sup>2</sup>	–	–	35 mm <sup>2</sup>
R6i	ACN 634 0070 5	70–10	–	70 mm <sup>2</sup>	70–10	–	70 mm <sup>2</sup>
	ACN 634 0100 5	70–10	–	70 mm <sup>2</sup>	70–10	–	70 mm <sup>2</sup>
<i>(Continued)</i>							

Module		DC Connection			AC Connection		
		Connection Type		Cross-section (per leg)	Connection Type		Cross-section (per leg)
Frame	Type	Cable Lug	Connection Hole for Busbar		Cable Lug	Connection Hole for Busbar	
<i>500 V (Continued)</i>							
R7i	ACN 634 0120 5	120–10	–	120 mm <sup>2</sup>	120–10	–	95 mm <sup>2</sup>
	ACN 634 0140 5	120–10	–	120 mm <sup>2</sup>	120–10	–	95 mm <sup>2</sup>
R8i	ACN 634 0215 5	–	Ø10 mm (M8)	4 × 40 mm	–	Ø11 mm (M8)	6 × 25 mm
	ACN 634 0255 5	–	Ø10 mm (M8)	4 × 40 mm	–	Ø11 mm (M8)	6 × 25 mm
	ACN 634 0325 5	–	Ø10 mm (M8)	4 × 40 mm	–	Ø11 mm (M8)	6 × 25 mm
R9i	ACN 634 0395 5	–	Ø10 mm (M8)	4 × 40 mm	–	Ø11 mm (M8)	6 × 25 mm
	ACN 634 0495 5	–	Ø10 mm (M8)	4 × 40 mm	–	Ø11 mm (M8)	6 × 25 mm
R10i	ACN 634 0615 5	–	Ø10 mm (M8)	2 × (4 × 40 mm)*	–	Ø11 mm (M8)	10 × 80 mm** 6 × 25 mm***
R11i	ACN 634 0775 5	–	Ø10 mm (M8)	2 × (4 × 40 mm)*	–	Ø11 mm (M8)	10 × 80 mm** 6 × 25 mm***
	ACN 634 0935 5	–	Ø10 mm (M8)	2 × (4 × 40 mm)*	–	Ø11 mm (M8)	10 × 80 mm** 6 × 25 mm***
R12i	ACN 634 1095 5	–	Ø10 mm (M8)	3 × (4 × 40 mm)*	–	Ø11 mm (M8)	3 × 284 mm** 3 × (6 × 25) mm***
	ACN 634 1385 5	–	Ø10 mm (M8)	3 × (4 × 40 mm)*	–	Ø11 mm (M8)	3 × 284 mm** 3 × (6 × 25) mm***
<i>690 V</i>							
R3i	ACN 634 0009 6	–	–	6 mm <sup>2</sup>	–	–	10 mm <sup>2</sup>
	ACN 634 0011 6	–	–	6 mm <sup>2</sup>	–	–	10 mm <sup>2</sup>
	ACN 634 0016 6	–	–	6 mm <sup>2</sup>	–	–	10 mm <sup>2</sup>
	ACN 634 0020 6	–	–	6 mm <sup>2</sup>	–	–	10 mm <sup>2</sup>
R4i	ACN 634 0025 6	–	–	10 mm <sup>2</sup>	–	–	16 mm <sup>2</sup>
	ACN 634 0030 6	–	–	10 mm <sup>2</sup>	–	–	16 mm <sup>2</sup>
R5i	ACN 634 0040 6	–	–	35 mm <sup>2</sup>	–	–	35 mm <sup>2</sup>
	ACN 634 0050 6	–	–	35 mm <sup>2</sup>	–	–	35 mm <sup>2</sup>
R6i	ACN 634 0060 6	70–10	–	70 mm <sup>2</sup>	70–10	–	70 mm <sup>2</sup>
	ACN 634 0070 6	70–10	–	70 mm <sup>2</sup>	70–10	–	70 mm <sup>2</sup>
R7i	ACN 634 0100 6	120–10	–	120 mm <sup>2</sup>	120–10	–	95 mm <sup>2</sup>
	ACN 634 0120 6	120–10	–	120 mm <sup>2</sup>	120–10	–	95 mm <sup>2</sup>
<i>(Continued)</i>							

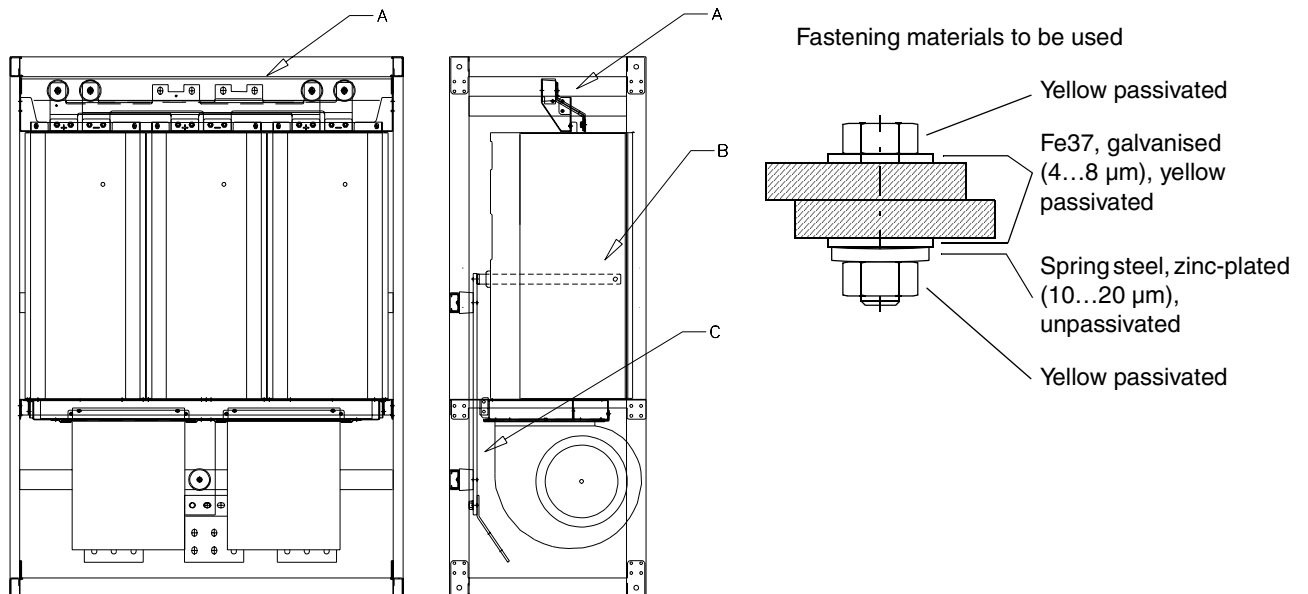


Module		DC Connection			AC Connection		
		Connection Type		Cross-section (per leg)	Connection Type		Cross-section (per leg)
Frame	Type	Cable Lug	Connection Hole for Bus-bar		Cable Lug	Connection Hole for Busbar	
690 V (Continued)							
R8i	ACN 634 0185 6	–	Ø10 mm (M8)	4 × 40 mm	–	Ø11 mm (M8)	6 × 25 mm
	ACN 634 0205 6	–	Ø10 mm (M8)	4 × 40 mm	–	Ø11 mm (M8)	6 × 25 mm
	ACN 634 0255 6	–	Ø10 mm (M8)	4 × 40 mm	–	Ø11 mm (M8)	6 × 25 mm
	ACN 634 0315 6	–	Ø10 mm (M8)	4 × 40 mm	–	Ø11 mm (M8)	6 × 25 mm
R9i	ACN 634 0375 6	–	Ø10 mm (M8)	4 × 40 mm	–	Ø11 mm (M8)	6 × 25 mm
	ACN 634 0485 6	–	Ø10 mm (M8)	4 × 40 mm	–	Ø11 mm (M8)	6 × 25 mm
R10i	ACN 634 0605 6	–	Ø10 mm (M8)	4 × 40 mm	–	Ø11 mm (M8)	10 × 80 mm** 6 × 25 mm***
R11i	ACN 634 0755 6	–	Ø10 mm (M8)	2 × (4 × 40 mm)*	–	Ø11 mm (M8)	10 × 80 mm** 6 × 25 mm***
	ACN 634 0905 6	–	Ø10 mm (M8)	2 × (4 × 40 mm)*	–	Ø11 mm (M8)	10 × 80 mm** 6 × 25 mm***
R12i	ACN 634 1045 6	–	Ø10 mm (M8)	3 × (4 × 40 mm)*	–	Ø11 mm (M8)	3 × 284 mm** 3 × (6 × 25) mm***
	ACN 634 1385 6	–	Ø10 mm (M8)	3 × (4 × 40 mm)*	–	Ø11 mm (M8)	3 × 284 mm** 3 × (6 × 25) mm***

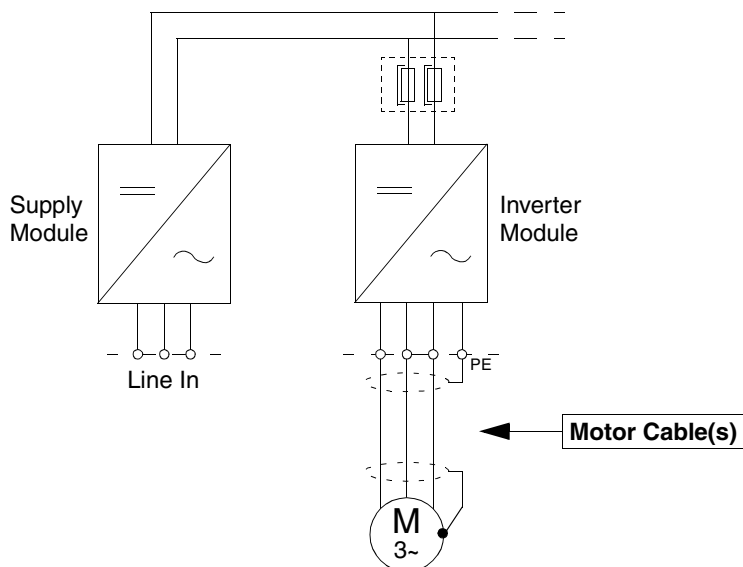
\*DC busbar connection point as provided by the optional mounting frame. See item **A** below.

\*\*AC busbar(s) of the module as provided by the optional mounting frame. See item **C** below.

\*\*\*AC busbar(s) of the individual phase modules. See item **B** below.



## Motor Cable Dimensioning



Suitable motor cable types are screened types with a nominal voltage of 1 kV. **Unscreened cables are not allowed** due to EMC requirements.

- External motor cables are selected according to the continuous load current of the motor.
- The maximum motor cable length is 300 m. If longer cables are required, contact an ABB representative for information.
- The inverter module has an electronic overload protection which limits the largest permissible load current.
- If more motors than one are connected to the inverter module, a separate thermal overload switch or a compact circuit breaker must be used for protecting the cable and the motor. These devices may require a separate fuse to cut off the short circuit current.

The tables below give the copper and aluminium cable types for different load currents ( $I_{Lmax}$ ). A correction factor of  $K = 0.70$  has been used (max. 9 cables laid on a cable ladder side by side, three ladders on top of each other, ambient temperature 30 °C, EN 60204-1 and IEC 364-5-523).

Detailed information on cable types and cabling practices can be found in *Grounding and cabling of the drive system* (3AFY 61201998).

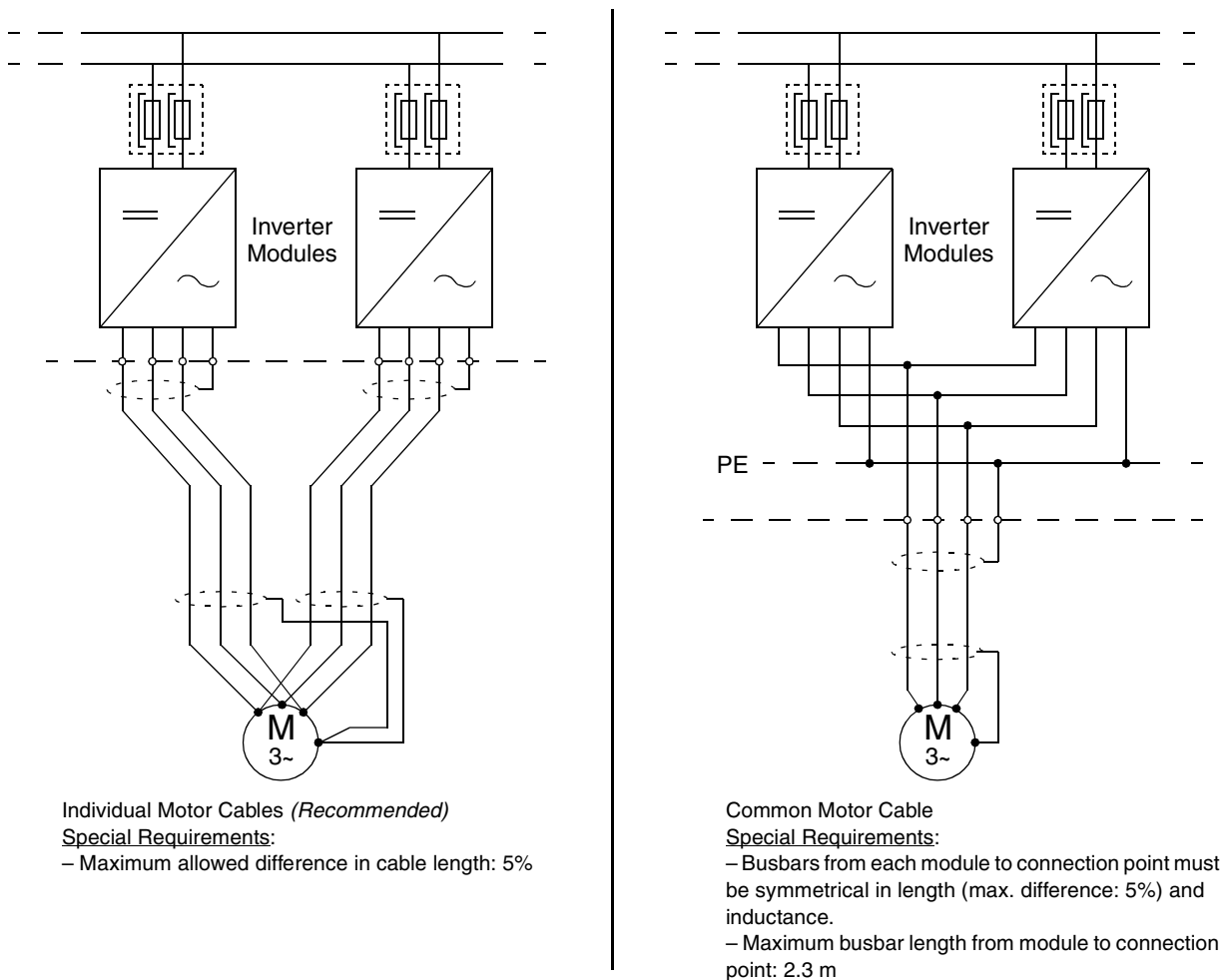
<i>COPPER CABLES WITH CONCENTRIC COPPER SCREEN</i>		
$I_{Lmax}$ [A]	Cable Type	Diameter [mm]
13	3×1.5 + 1.5	13
18	3×2.5 + 2.5	14
24	3×4 + 4	16
30	3×6 + 6	18
42	3×10 + 10	21
56	3×16 + 16	23
71	3×25 + 16	24
88	3×35 + 16	26
107	3×50 + 25	29
137	3×70 + 35	32
167	3×95 + 50	38
193	3×120 + 70	41
223	3×150 + 70	44
255	3×185 + 95	50
274	2 × (3×70 + 35)	2 × 32
301	3×240 + 120	55
334	2 × (3×95 + 50)	2 × 38
386	2 × (3×120 + 70)	2 × 41
446	2 × (3×150 + 70)	2 × 44
510	2 × (3×185 + 95)	2 × 50
579	3 × (3×120 + 70)	3 × 41
602	2 × (3×240 + 120)	2 × 55
669	3 × (3×150 + 70)	3 × 44
765	3 × (3×185 + 95)	3 × 50
772	4 × (3×120 + 70)	4 × 41
892	4 × (3×150 + 70)	4 × 44
903	3 × (3×240 + 120)	3 × 55
1020	4 × (3×185+ 95)	4 × 50

<i>ALUMINIUM CABLES WITH CONCENTRIC COPPER SCREEN</i>		
$I_{Lmax}$ [A]	Cable Type	Diameter [mm]
69	3×35Al + 10Cu	26
83	3×50Al + 15Cu	29
107	3×70Al + 21Cu	32
130	3×95Al + 29Cu	38
151	3×120Al + 41Cu	41
174	3×150Al + 41Cu	44
199	3×185Al + 57Cu	49
214	2 × (3×70Al + 21Cu)	2 × 32
235	3×240Al + 72Cu	54
260	2 × (3×95Al + 29Cu)	2 × 38
302	2 × (3×120Al + 41Cu)	2 × 41
348	2 × (3×150Al + 41Cu)	2 × 44
398	2 × (3×185Al + 57Cu)	2 × 49
470	2 × (3×240Al + 72Cu)	2 × 54
522	3 × (3×150Al + 41Cu)	3 × 44
597	3 × (3×185Al + 57Cu)	3 × 49
696	4 × (3×150Al + 41Cu)	4 × 44
705	3 × (3×240Al + 72Cu)	3 × 54
796	4 × (3×185Al + 57Cu)	4 × 49
940	4 × (3×240Al + 72Cu)	4 × 54
995	5 × (3×185Al + 57Cu)	5 × 49
1175	5 × (3×240Al + 72Cu)	5 × 54

**Parallel Connection of Inverter Modules**

Figure 2-31 presents the special requirements for different cabling options for parallel-connected inverter modules.

See also *Grounding and cabling of the drive system (3AFY 61201198)*.



*Figure 2-31 Cabling options and requirements for parallel-connected inverter modules.*

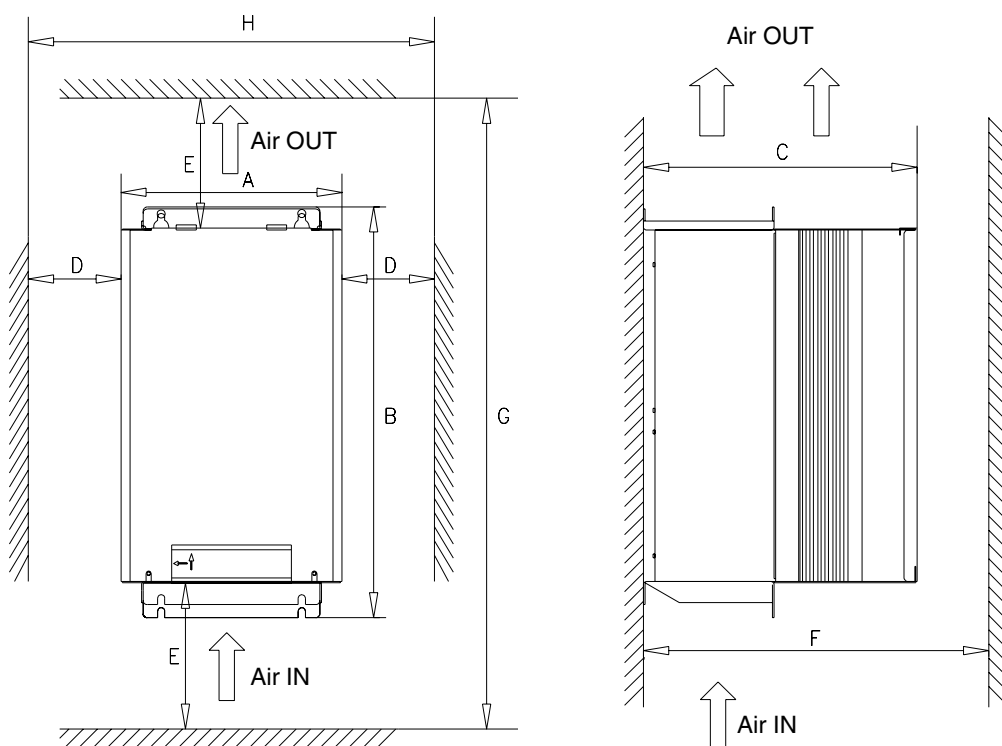
**Parallel Connection of IGBT Supply Modules**

It is practical to connect the inputs of the AC chokes together inside the drive cabinet quite like in the “Common Motor Cable” diagram in Figure 2-31 (above right). In general, the more symmetrical the busbar systems are, the better. However, the presence of the AC chokes result in the requirements being somewhat less critical than those specified for the Common Motor Cable connection.

**Frames R2i...R5i** Frame R2i...R5i inverter modules are fixed to the rear wall (or cooling air duct) of the cabinet with four M6 screws. No air baffle is needed.

It is also possible to mount several units in one cabinet. Two examples are shown below: one possible configuration has two rows of three modules, the other has three rows of two. The latter requires airflow guides (also illustrated). In all cases, the clearances shown below must be observed.

Cables are used for both the input and output connections. The connectors are located at the bottom of the module; frames R2i...R4i have the connections inside the module, while R5i has them on the outside.



FRAME SIZE	A	B	C	D	E	F	G	H	WEIGHT
R2	220	409	273	40	115	293	639	300	10 kg
R3	260	409	278.5	40	116	298.5	641	340	13 kg
R4	305.5	516	286	40	164	306	844	385.5	20 kg
R5	305.5	533	336	40	189.5	356	912	385.5	23 kg

*Figure 2-32 Frame R2i...R5i inverter module dimensions and clearances.*

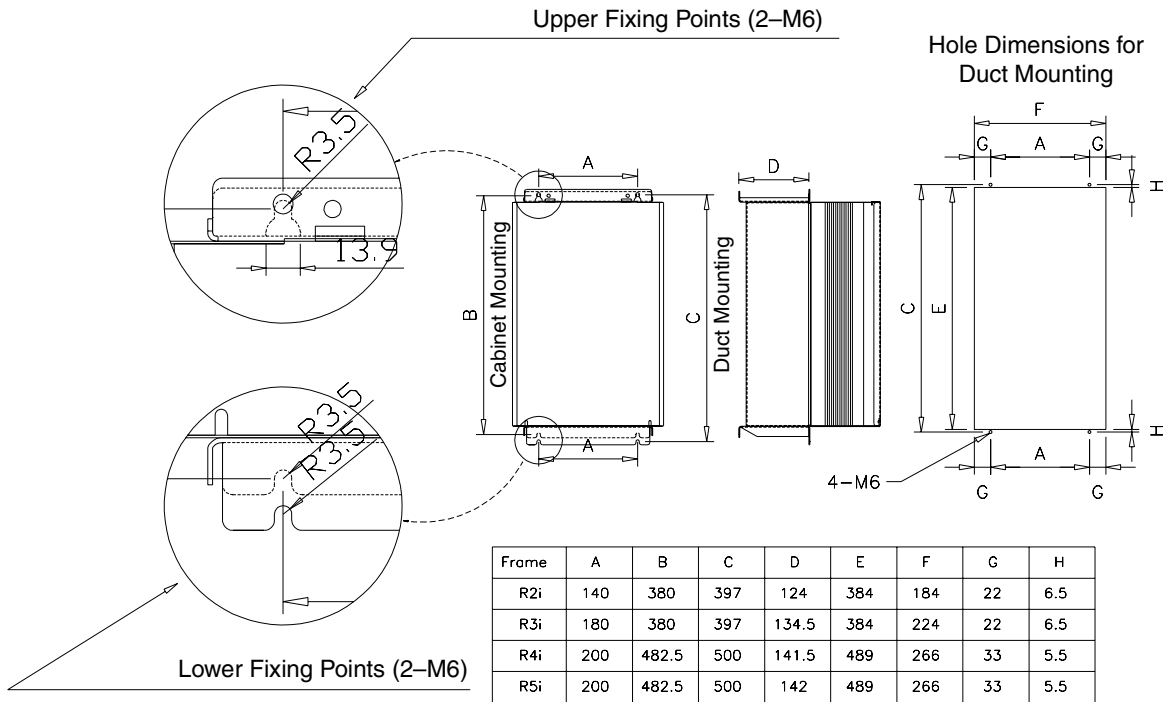


Figure 2-33 Installation of Frame R2i...R5i inverter modules.

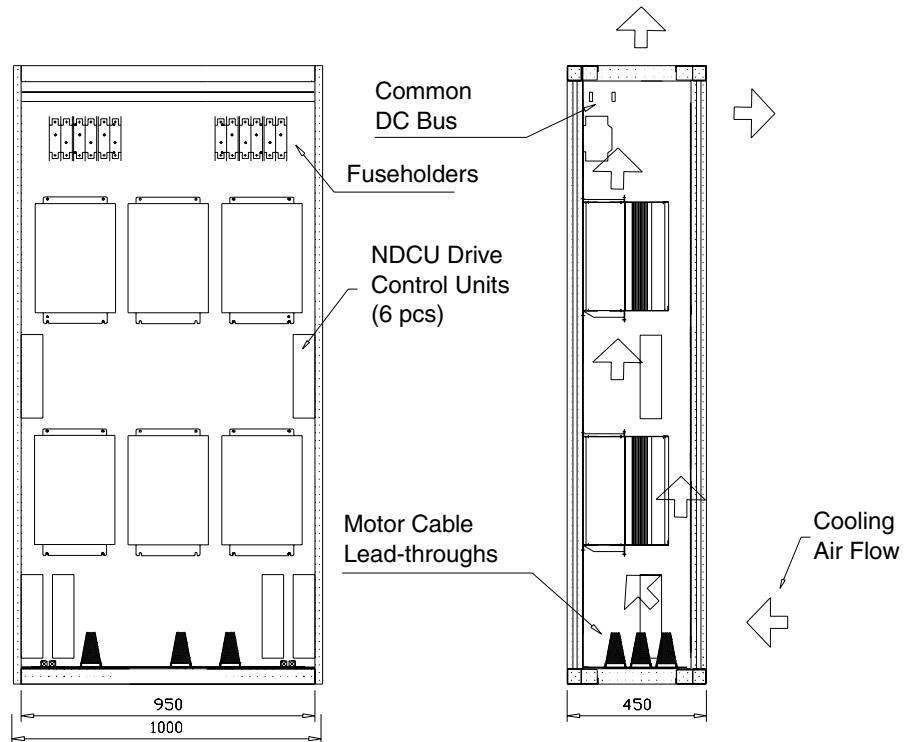


Figure 2-34 Cabinet layout example for six Frame R2i...R3i inverter modules. (Frame R3i depicted.)

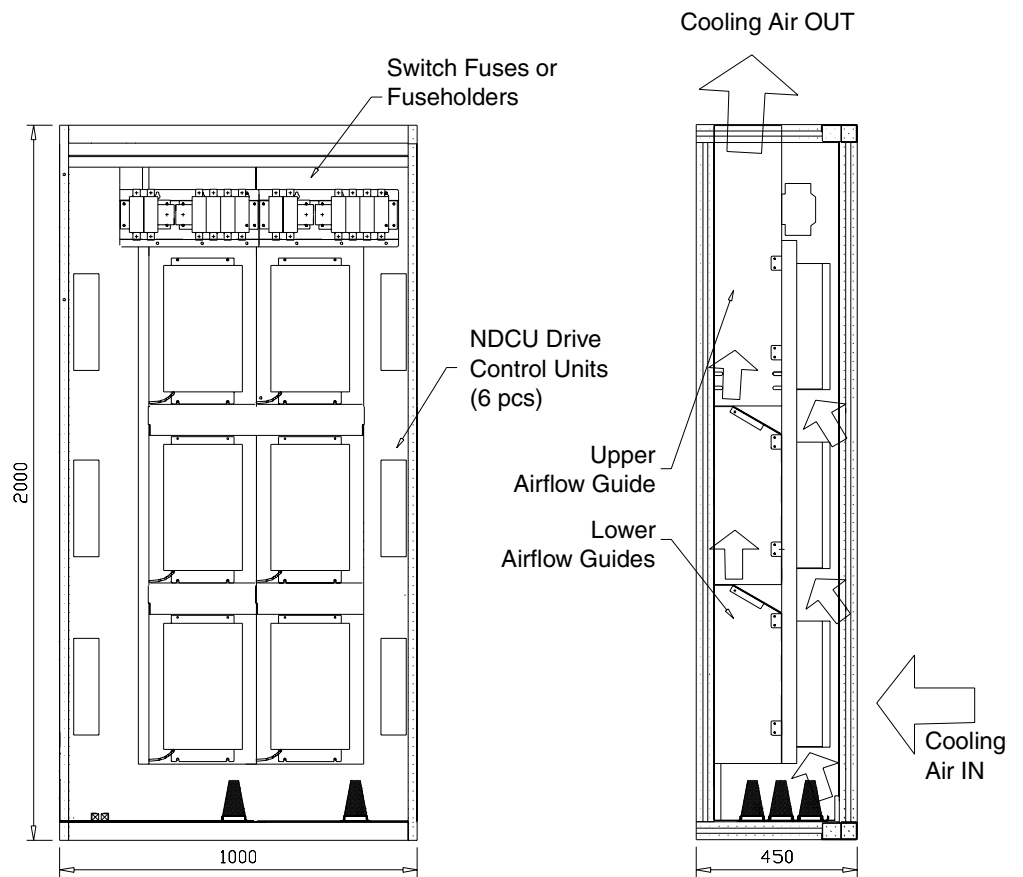
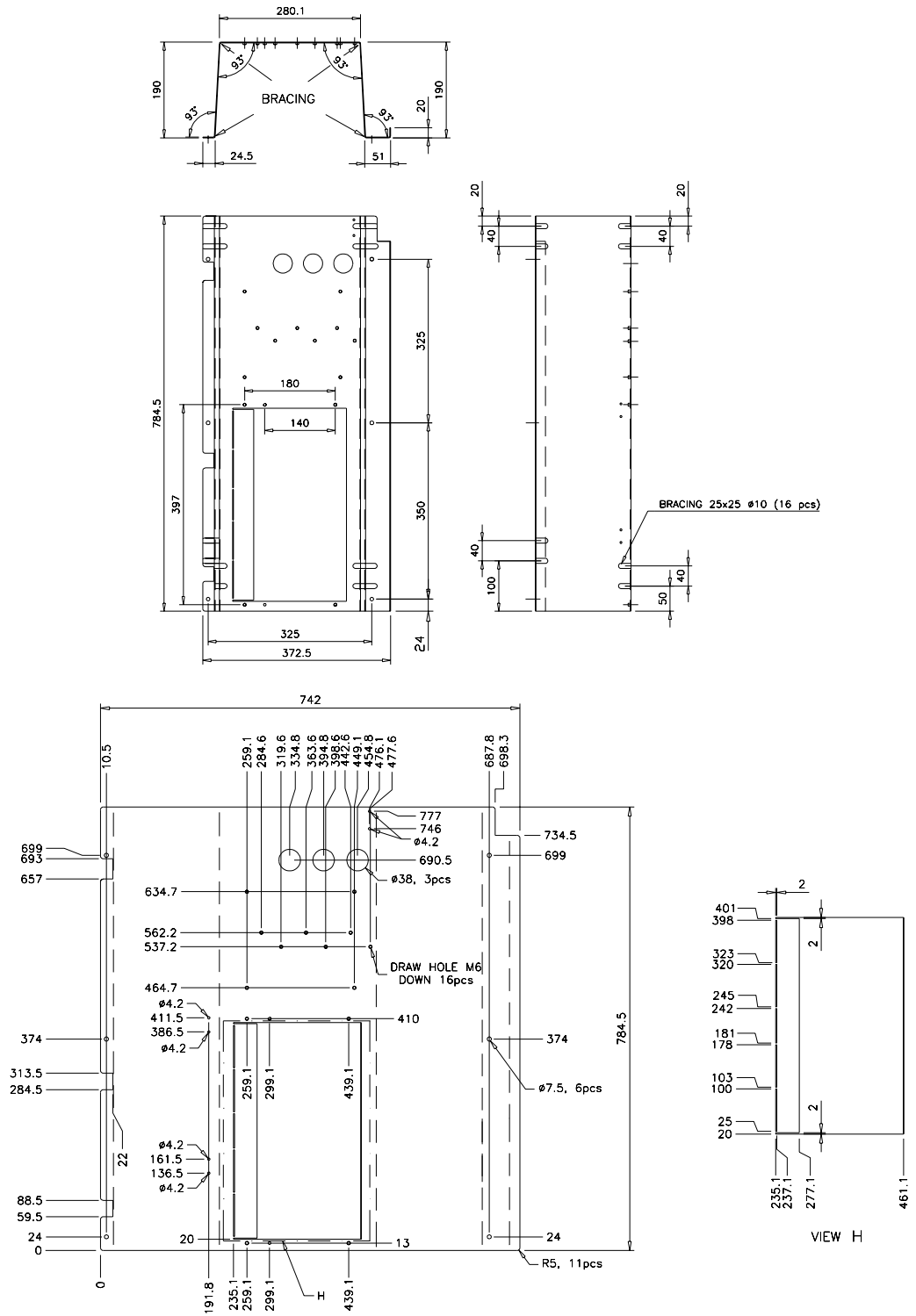


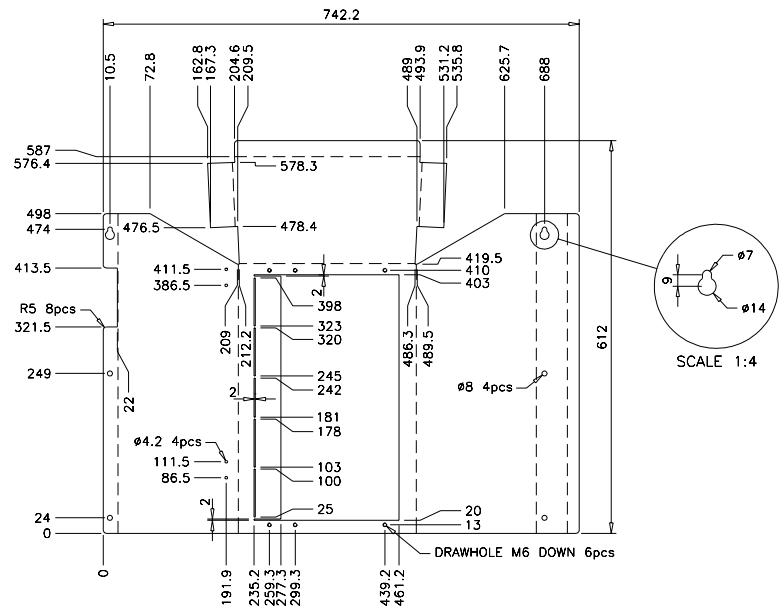
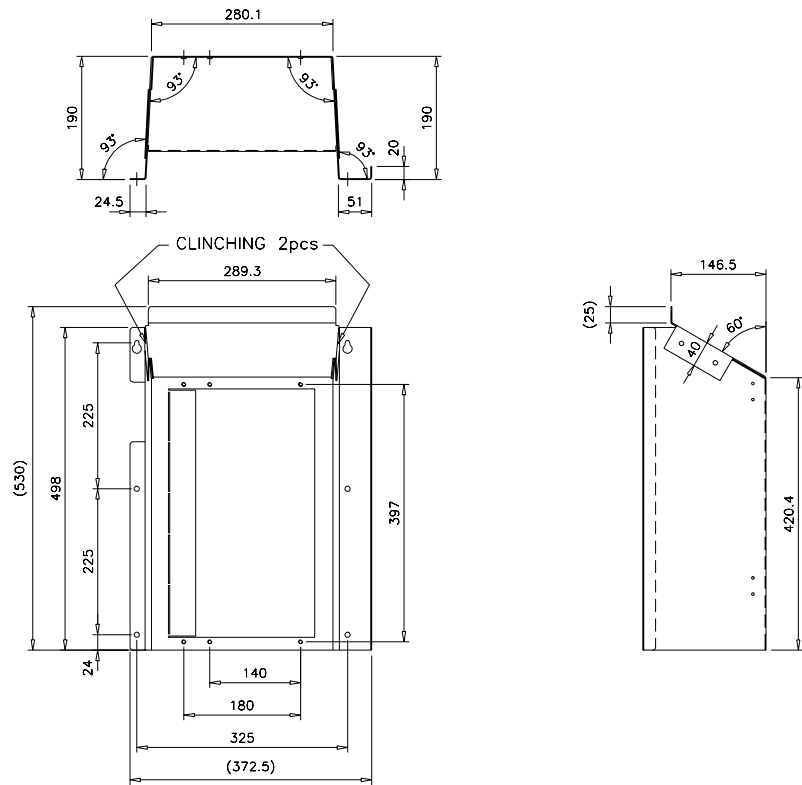
Figure 2-35 Cabinet layout example for six Frame R2i...R5i inverter modules – air duct installation. (Frame R3i depicted.)



MATERIAL: HOT-DIP ZINC COATED STEEL SHEET 1,5mm  
 EN 10142-DX51D+Z275-N-A-C  
 WEIGHT: 7.17 kg  
 DIMENSION WITHOUT TOLERANCE DIN 6930-m

Figure 2-36 Upper airflow guide dimensions (Frames R2i and R3i).

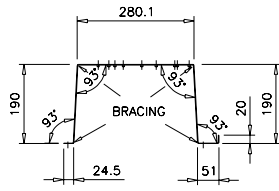




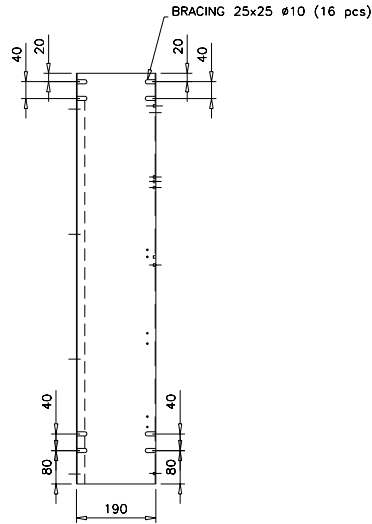
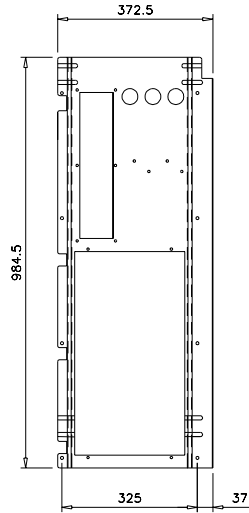
MATERIAL: HOT-DIP ZINC COATED STEEL SHEET 1,5mm  
 EN 10142-DX51D+Z275-N-A-C  
 WEIGHT: 5.45 kg  
 DIMENSION WITHOUT TOLERANCE DIN 6930-m

DETACHMENT OF BLANK

Figure 2-37 Lower airflow guide dimensions (Frames R2i and R3i).



ALL FOLDING RADII R= 1.5



MATERIAL: HOT-DIP ZINC COATED STEEL SHEET 1,5mm  
 EN 10142-DX51D+Z275-N-A-C  
 WEIGHT: 9 kg  
 DIMENSION WITHOUT TOLERANCE DIN 6930-m

DETACHMENT OF BLANK

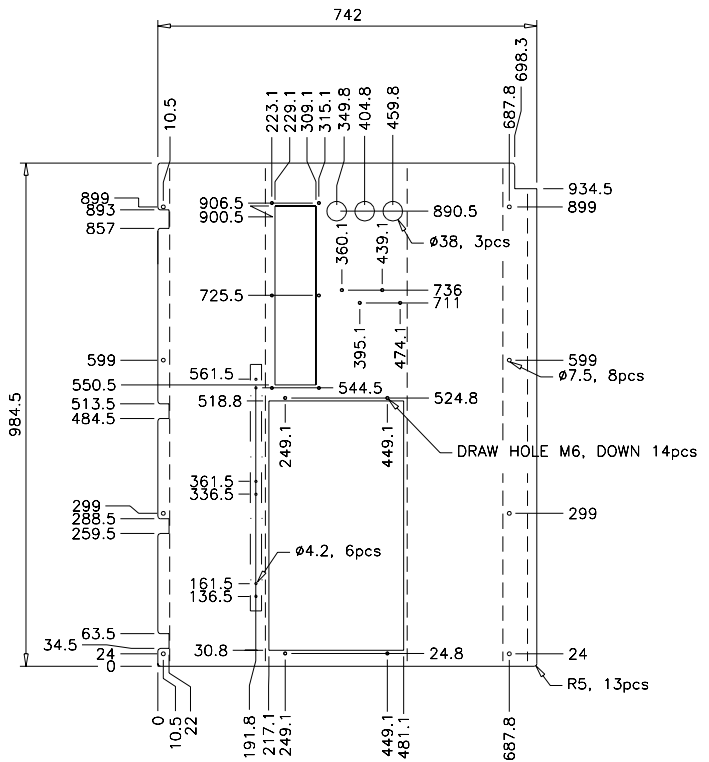
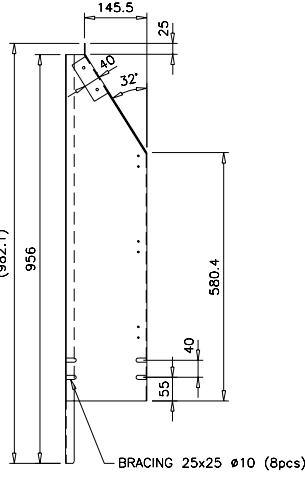
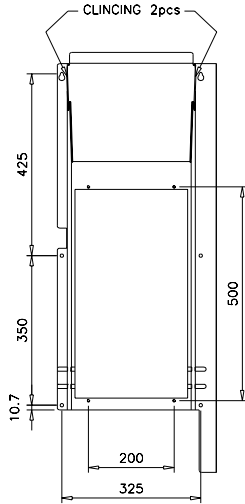
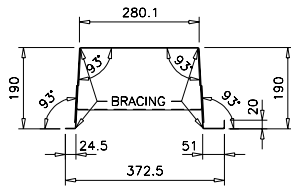
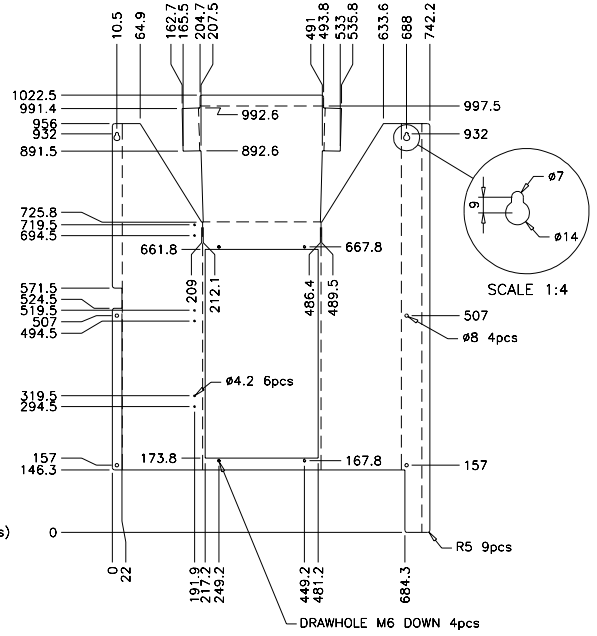


Figure 2-38 Upper airflow guide dimensions (Frames R4i and R5i).



ALL FOLDING RADII R= 1,5

DETACHMENT OF BLANK



MATERIAL: HOT-DIP ZINC COATED STEEL SHEET 1,5mm  
 EN 10142-DX51D+Z275-N-A-C  
 WEIGHT: 9.11 kg  
 DIMENSION WITHOUT TOLERANCE DIN 6930-m

Figure 2-39 Lower airflow guide dimensions (Frames R4i and R5i).

**Frames R6i, R7i**

The DC connectors are located at the top of the module, the AC connectors at the bottom of the module.

It is possible to mount several units in one cabinet providing the minimum clearances in Figure 2-40 below are followed.

The module can be installed in the cabinet using the optional mounting plate (ordering code 64138375) and a separate air baffle. Alternatively, a combined mounting plate/air baffle can be constructed – a suitable design is shown by Figure 2-43. The fixing points are shown in the cabinet layout examples below.

*Installation using the Mounting Plate (#64138375)*

The module is fastened by its two top fixing points to the rear wall of the cabinet using two M8 screws. The mounting plate (which connects the module and its cooling fan) is fixed to the rear wall of the cabinet with two M6 screws. The separate air baffle does not have to carry the weight of the module.

*Installation without the Mounting Plate*

The module is fixed to the rear wall with two M8 screws, and to the mounting plate/air baffle with four M6 screws. The cooling fan is also fixed to the plate which has to be strong enough to carry the weight the module. A suitable design for the mounting plate/air baffle is shown in Figure 2-43.

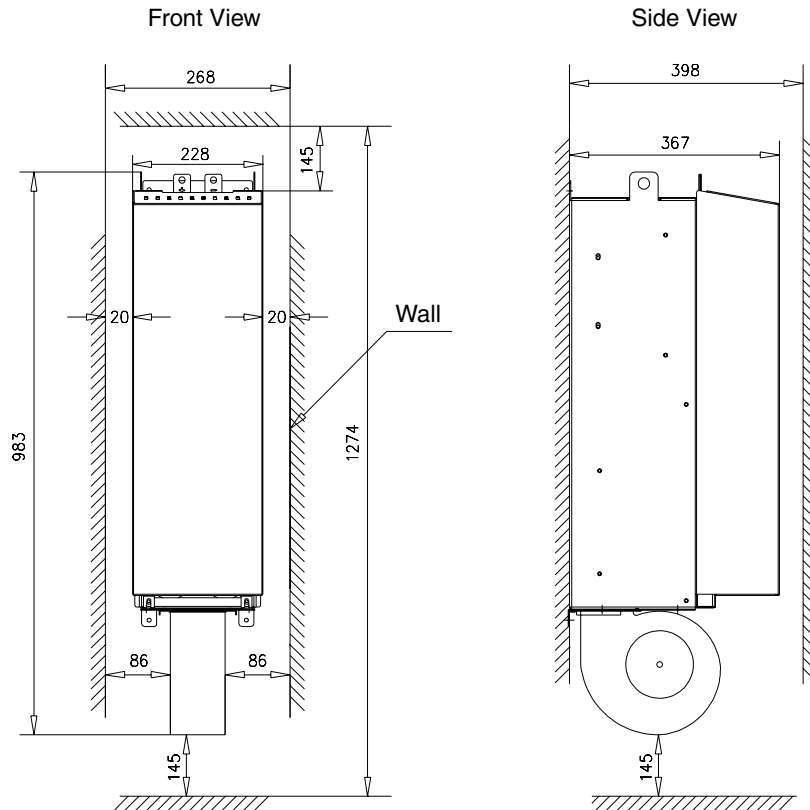


Figure 2-40 Frame R6i and R7i module dimensions and clearances.

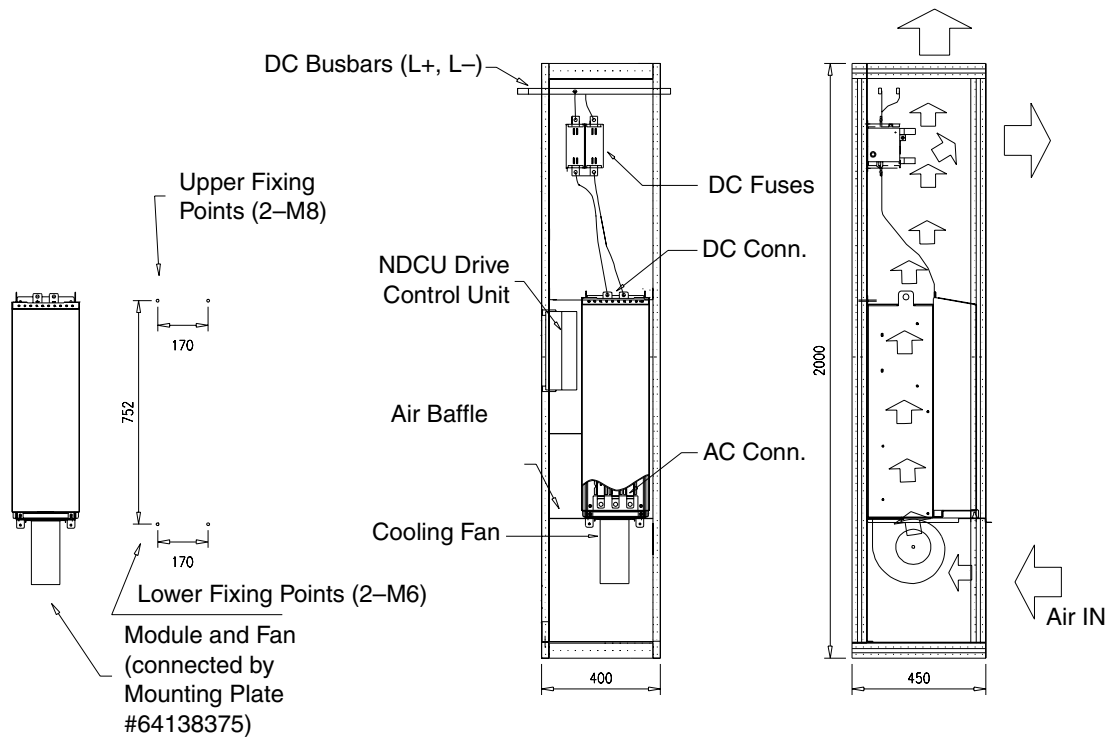


Figure 2-41 Cabinet layout example for R6i and R7i modules – Installation using mounting plate #64138375 and a separate air baffle.

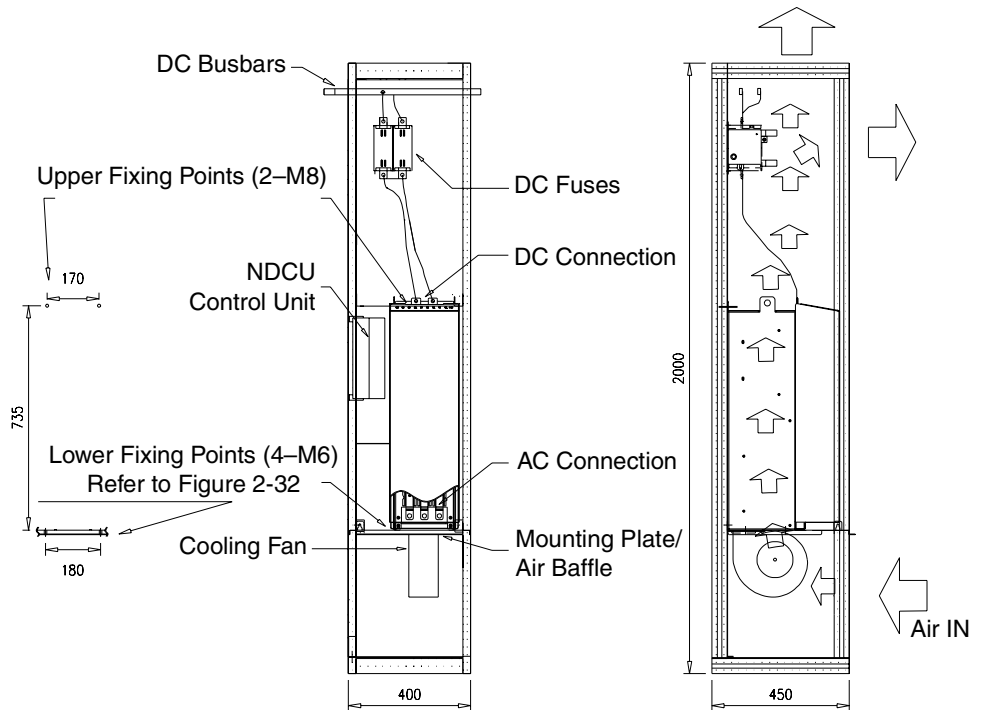
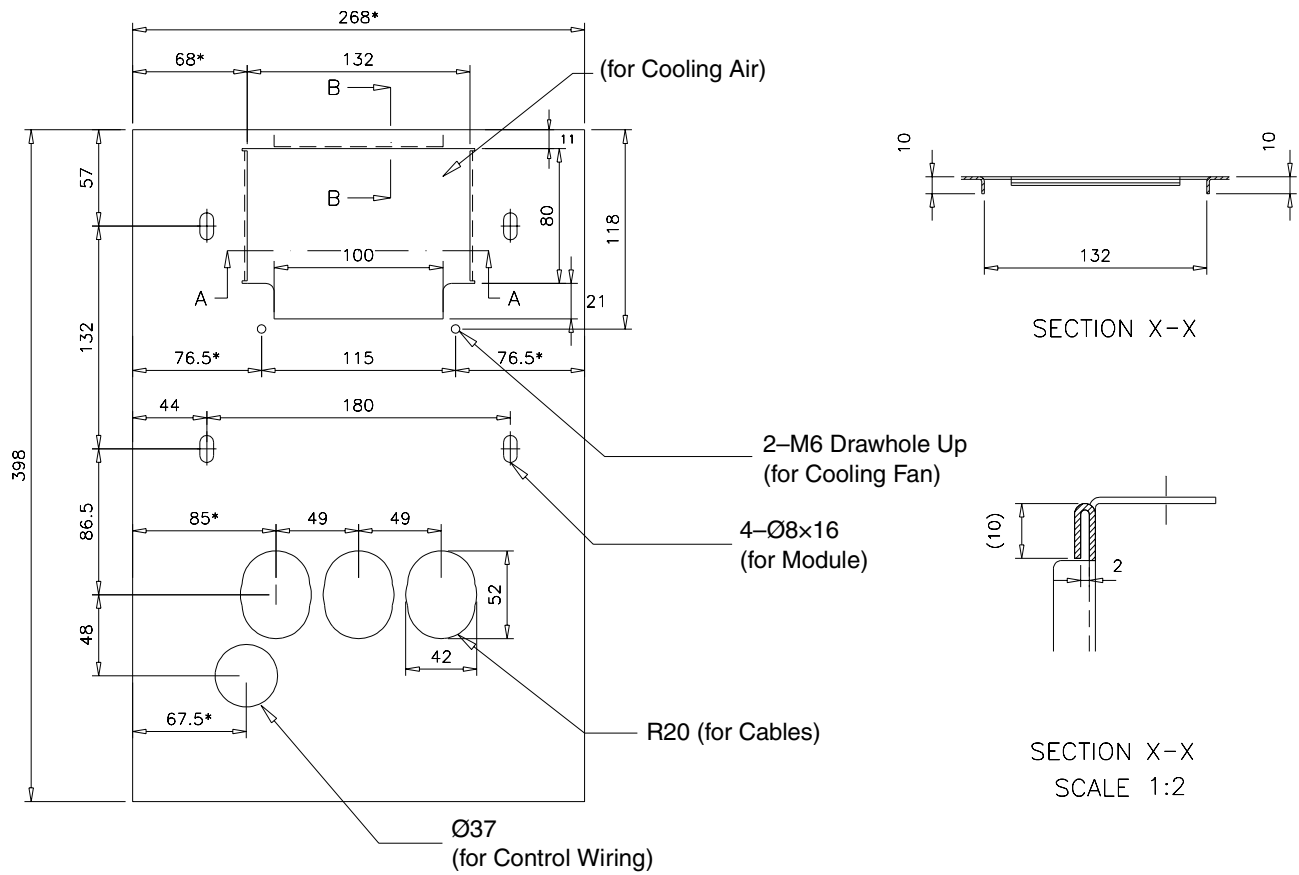


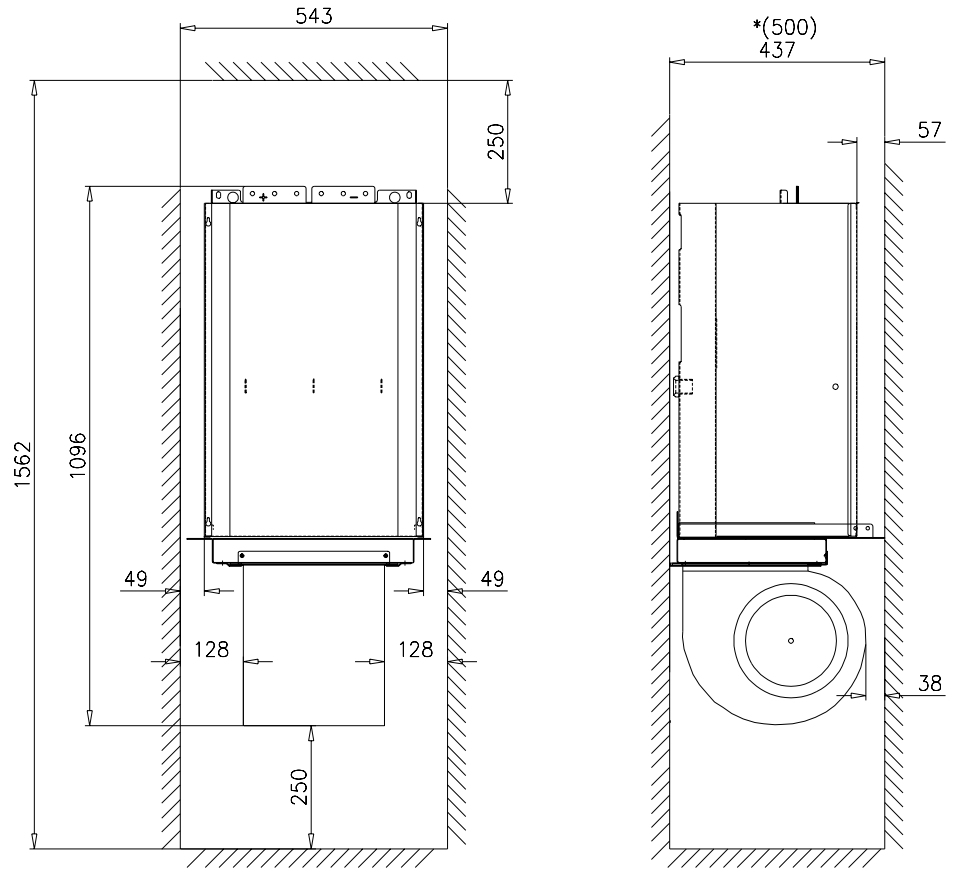
Figure 2-42 Cabinet layout example for R6i and R7i modules – Installation using the mounting plate/air baffle illustrated in Figure 2-43.



MATERIAL: HOT-DIP ZINC COATED STEEL SHEET 1,5mm  
 EN 10142-DX51D+Z275-N-A-C  
 DIMENSION WITHOUT TOLERANCE DIN 6930-m

Figure 2-43 Mounting plate/air baffle for Frame R6i and R7i modules.

**Frames R8i, R9i**



*Note:* DC and AC busbars are not included in the dimensions.

\*Typical depth including AC busbars.  
(See Mounting Frame dimensional drawing)

FRAME SIZE	MODULE TYPE	WEIGHT (kg)
R8	ACN 634-0185-3	60
	ACN 634-0225-3	63
	ACN 634-0265-3	65
	ACN 634-0215-5	63
	ACN 634-0255-5	66
	ACN 634-0325-5	66
	ACN 634-0185-6	63
	ACN 634-0205-6	63
	ACN 634-0255-6	66
	ACN 634-0315-6	66
R9	ACN 634-0335-3	65
	ACN 634-0405-3	67
	ACN 634-0395-5	69
	ACN 634-0495-5	72
	ACN 634-0375-6	69
	ACN 634-0485-6	72

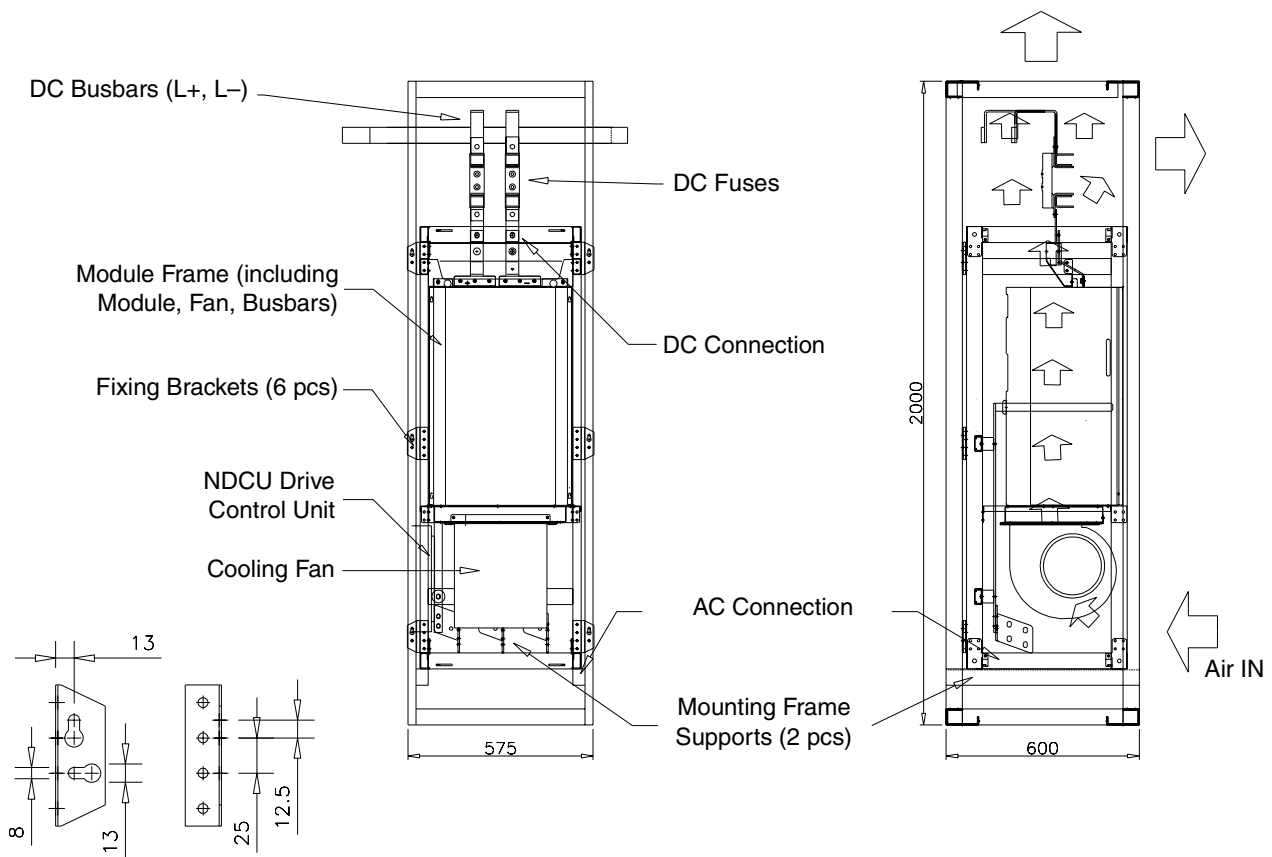
Figure 2-44 Frame R8i and R9i module dimensions and clearances.

*Installation Using the Mounting Frame*

Frame R8i and R9i modules are most conveniently installed using the mounting frame available in the ACS 600 MultiDrive Modules product line. The mounting frame stands on supports fastened to the cabinet, and is fixed to the rear wall of the cabinet at 2...6 points with the brackets included. The frame has mounting holes pitched at 25 mm.

An air baffle has to be used for preventing air recirculation if the cabinet is wider or deeper than the mounting frame.

Busbars are used for both the input and output connections. The input connectors are located at the top of the frame, the output connectors at the bottom.



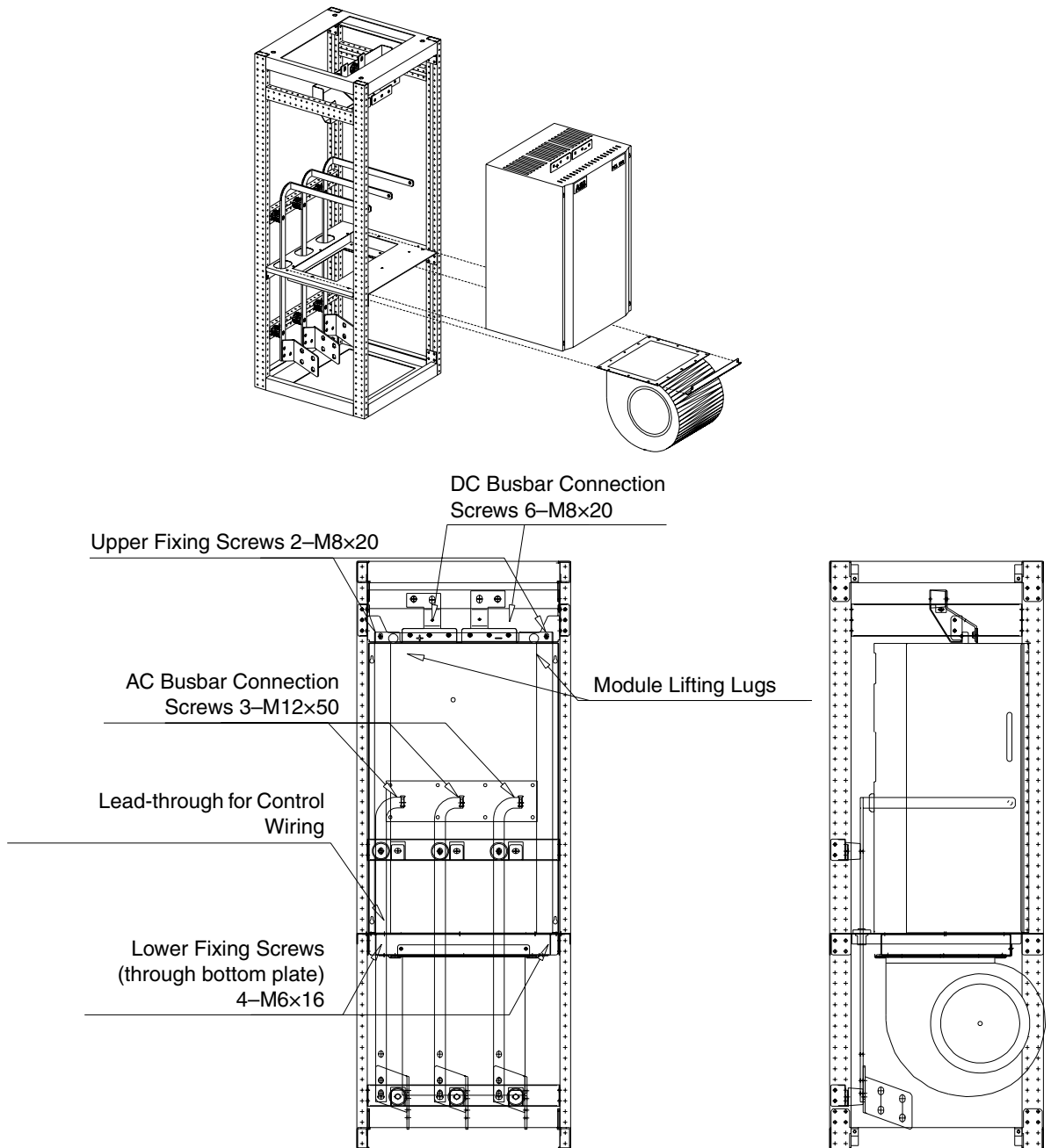
*Figure 2-45 Cabinet layout example for R8i and R9i modules – Installation using the mounting frame.*



*Installing the Module in the Mounting Frame*

Follow these steps (refer to Figure 2-46 below):

1. Lift the module into its place in the frame.
2. Put all module fixing and busbar connection screws into their positions – do not tighten yet.
3. Tighten the module fixing screws to their final torque.
4. Tighten the busbar connection screws to their final torque.

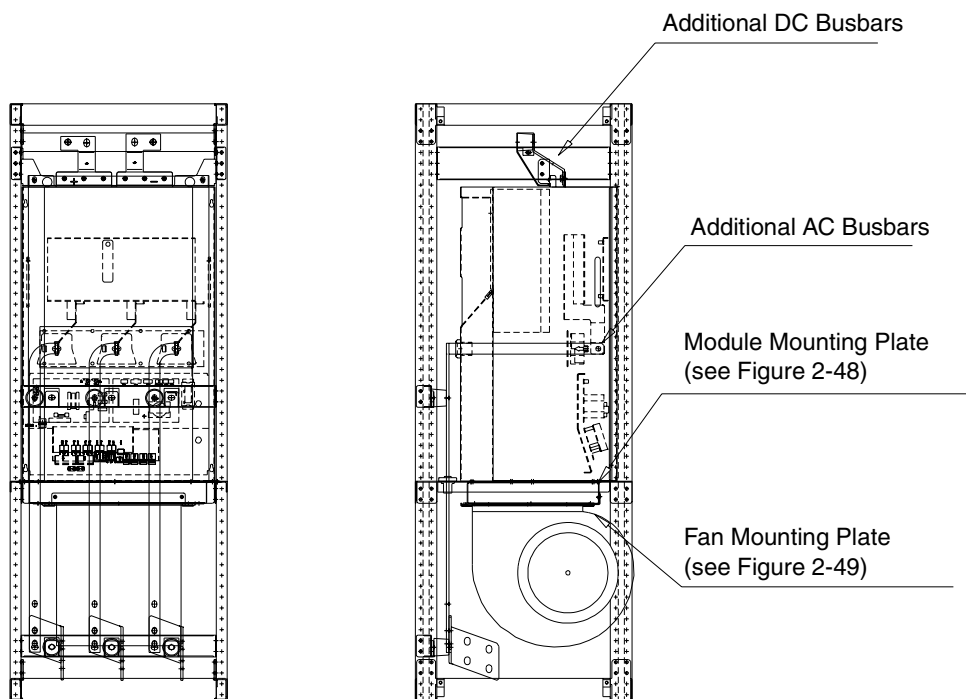


*Figure 2-46 Installing an R8i/R9i module in a mounting frame.*

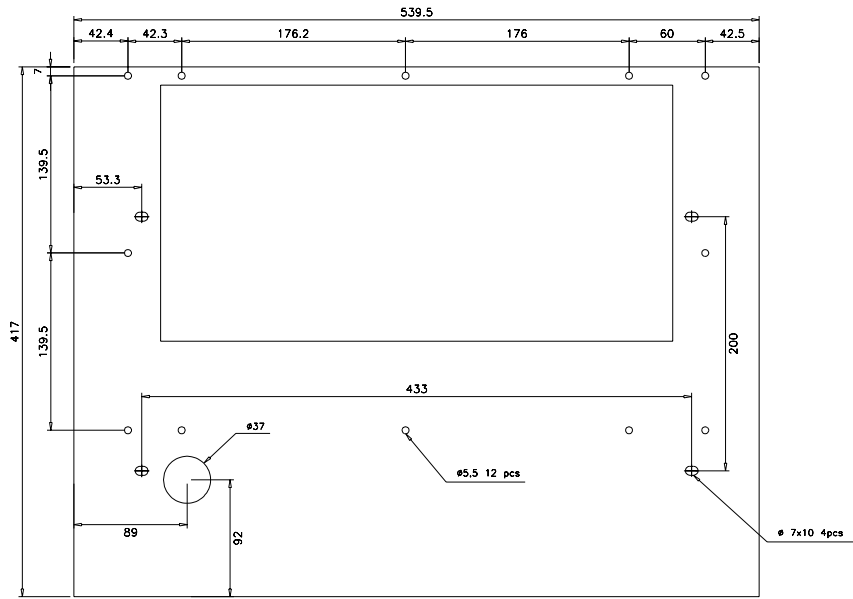
*Installation without the Mounting Frame*

If the mounting frame is not used, these issues must be considered:

- The AC cables must not be connected directly to the AC busbars of the module. Well-supported additional busbars must be used instead.
- Air recirculation inside the cabinet must be prevented. The module mounting plate (shown in Figure 2-48) can also be used as an air baffle by increasing its total width and depth. Alternatively, a separate air baffle can be used.
- A space between the fan and the module is necessary for even cooling air distribution. Constructing a fan mounting plate like the one presented in Figure 2-49 is recommended.
- The clearances shown in Figure 2-44 must be observed. Special attention must be paid to the length of the additional AC busbars inside the module: a sufficient clearance must be left between the busbars and the inside of the module front cover.

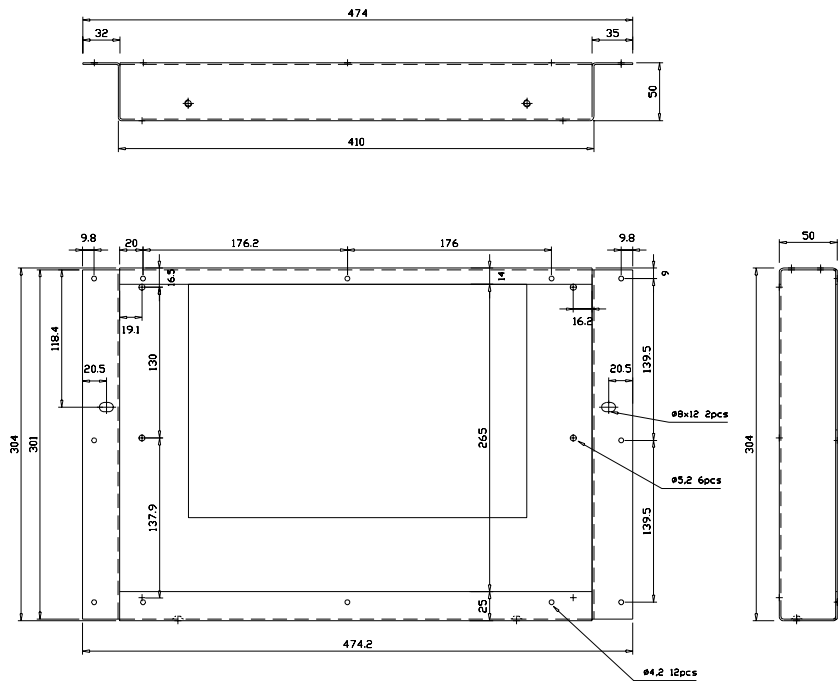


*Figure 2-47 R8i/R9i installation without the mounting frame.*



MATERIAL: HOT-DIP ZINC COATED STEEL SHEET 2mm  
 EN 10142-DX51D+Z275-N-A-C  
 DIMENSION WITHOUT TOLERANCE DIN 6930-m

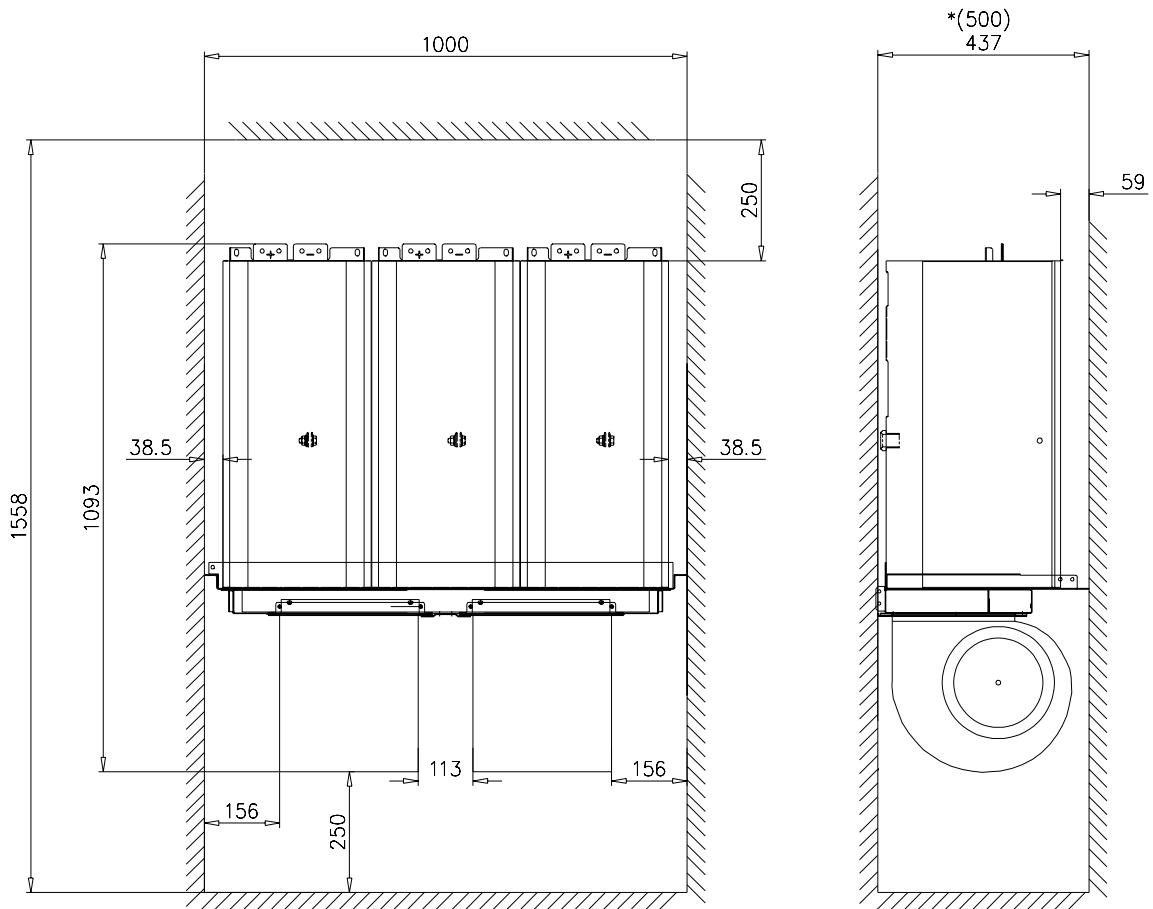
Figure 2-48 Module mounting plate for Frame R8i/R9i modules.



MATERIAL: HOT-DIP ZINC COATED STEEL SHEET 1,5mm  
 EN 10142-DX51D+Z275-N-A-C  
 DIMENSION WITHOUT TOLERANCE DIN 6930-m

Figure 2-49 Fan mounting plate for Frame R8i/R9i modules.

**Frames R10i, R11i**



**Note:** DC and AC busbars are not included in the dimensions.

\*Typical depth including AC busbars. (See Mounting Frame dimensional drawing)

FRAME SIZE	MODULE TYPE	WEIGHT (kg)
R10	ACN 634-0505-3	129
	ACN 634-0615-5	136
	ACN 634-0605-6	136
R11	ACN 634-0630-3	135
	ACN 634-0765-3	145
	ACN 634-0770-5	145
	ACN 634-0935-5	145
	ACN 634-0755-6	145
	ACN 634-0905-6	145

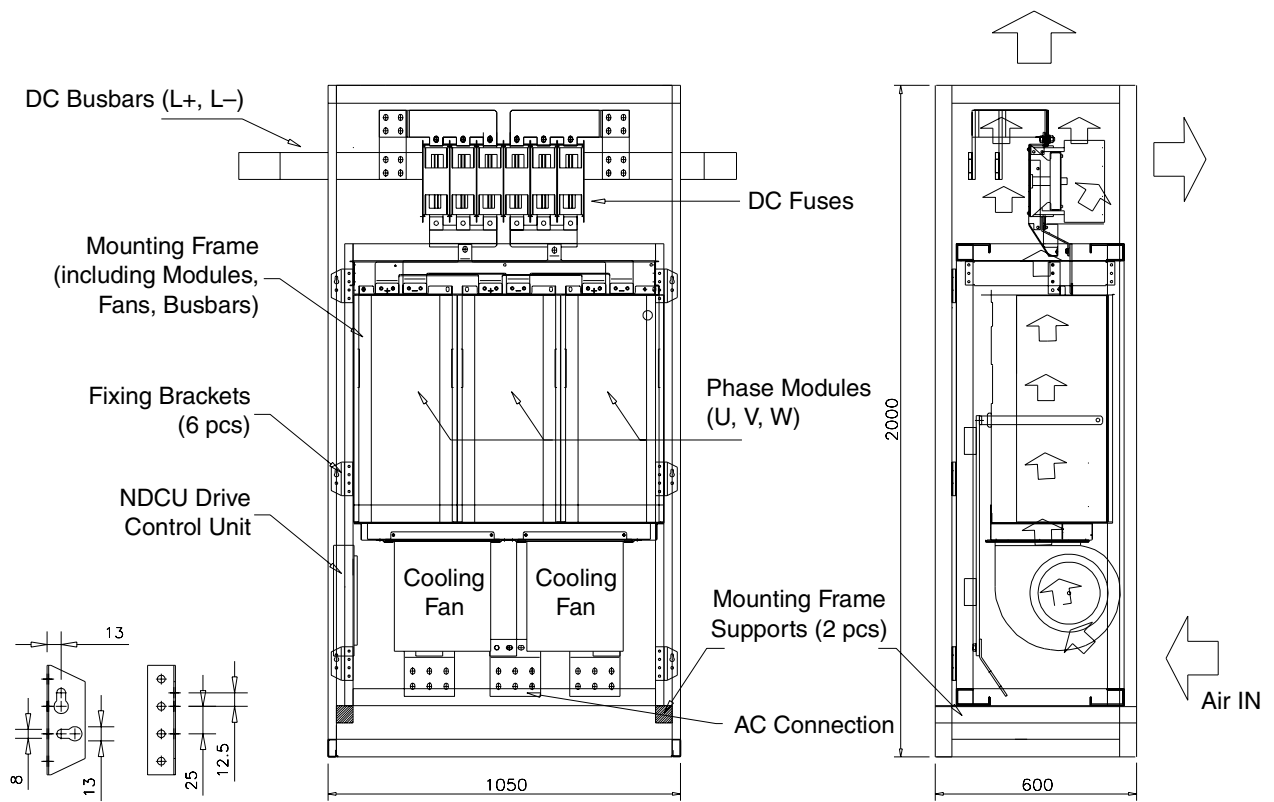
Figure 2-50 Frame R10 and R11i module dimensions and clearances.

*Installation Using the Mounting Frame*

Frame R10i and R11i modules are most conveniently installed using the mounting frame available in the ACS 600 MultiDrive Modules product line. The mounting frame stands on supports fastened to the cabinet, and is fixed to the rear wall of the cabinet at 4...6 points with the brackets included. The frame has mounting holes pitched at 25 mm.

An air baffle has to be used for preventing air recirculation if the cabinet is wider or deeper than the mounting frame.

Busbars are used for both the DC and AC connections. The DC connectors (3 points per leg) are located at the top of the module, the AC connectors at the bottom below the cooling fans.



*Figure 2-51 Cabinet layout example for R10i and R11i modules – Installation using the mounting frame.*

*Installing the  
Phase Modules in the  
Mounting Frame*

Follow these steps (refer to Figure 2-52 below):

1. Starting from one side, lift the modules into their place in the frame.
2. Put all module fixing and busbar connection screws into their positions – do not tighten yet.
3. Tighten the module fixing screws to their final torque.
4. Tighten the busbar connection screws to their final torque.

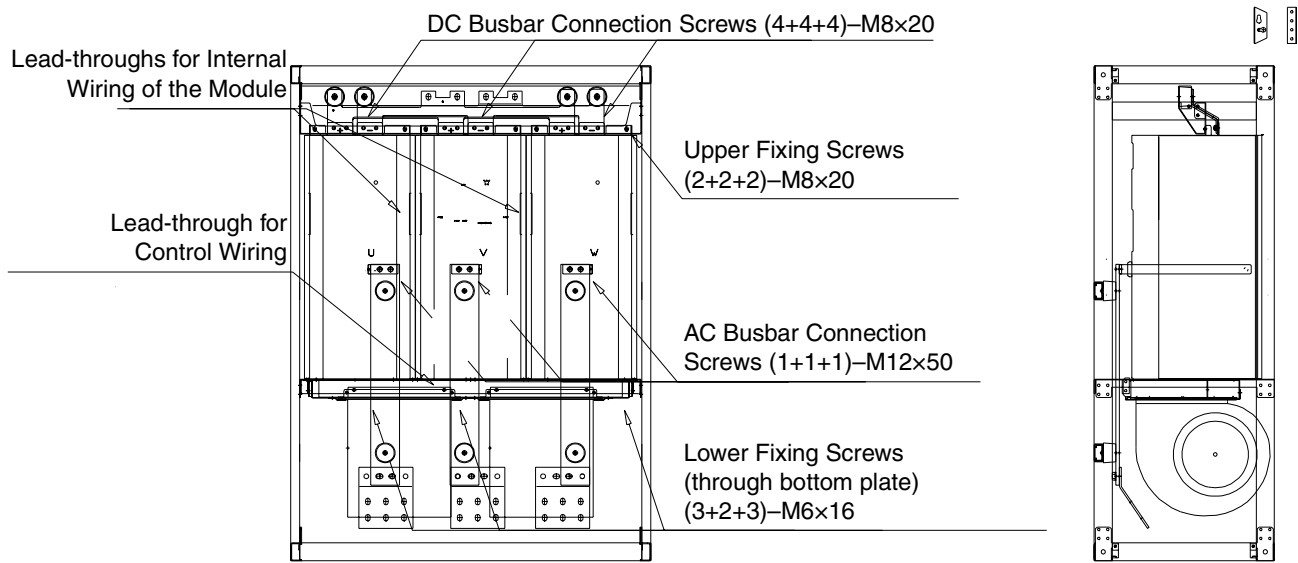
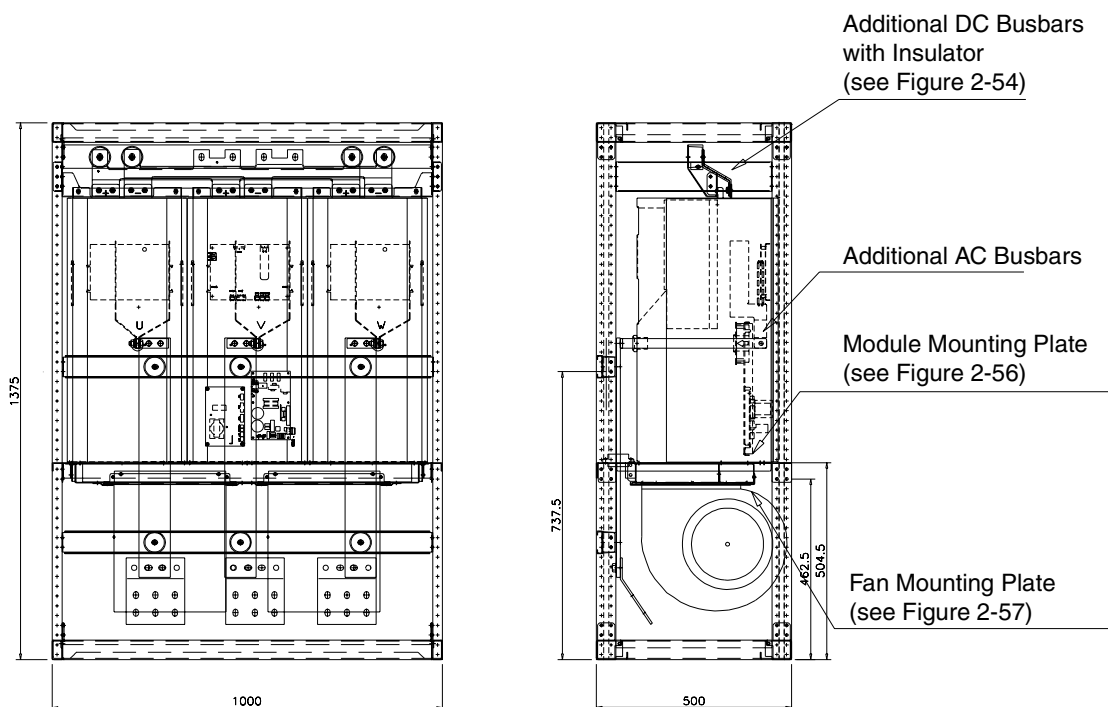


Figure 2-52 Installing R10i/R11i phase modules in the mounting frame.

*Installation without the Mounting Frame*

If the mounting frame is not used, these issues must be considered:

- The DC bus between the phase modules must have a low inductance. Therefore it is strongly recommended to construct the connecting busbars (and the insulator) exactly as shown in the drawings below.
- Air recirculation inside the cabinet must be prevented. The module mounting plate (shown in Figure 2-56) can also be used as an air baffle by increasing its total width and depth. Alternatively, a separate air baffle can be used.
- The space between the cooling fans and the phase modules must be as shown in the diagrams below to ensure even distribution of cooling air between the modules. Constructing a fan mounting plate like the one presented in Figure 2-57 is recommended.
- The clearances shown in Figure 2-50 must be observed. Special attention must be paid to the length of the additional AC busbars inside the phase modules – a sufficient clearance must be left between the busbar and the inside of the module front cover.



*Figure 2-53 R10i/R11i installation without the mounting frame.*

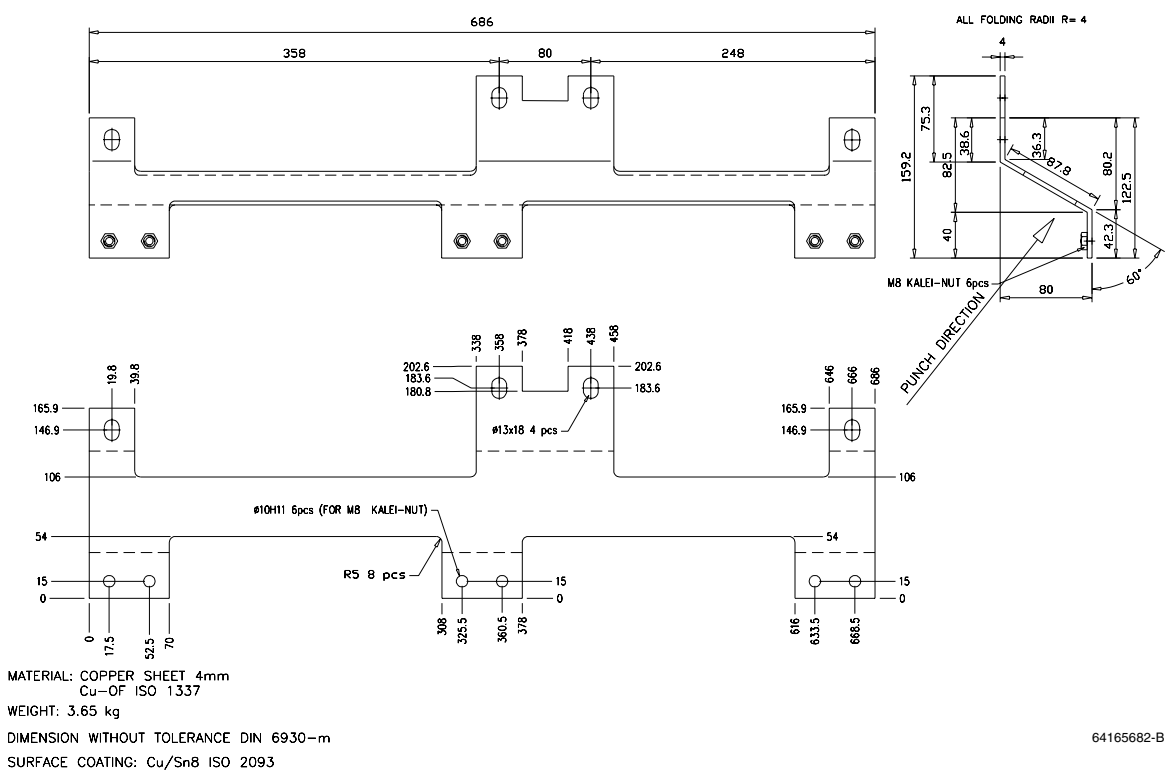
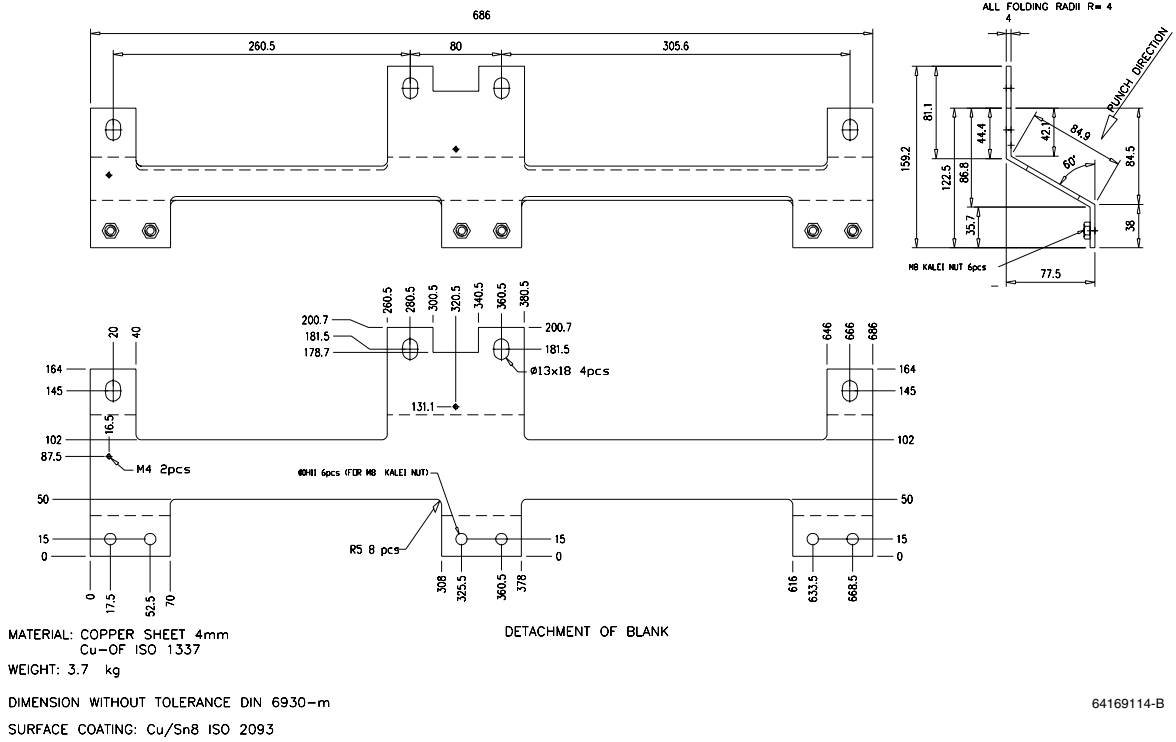
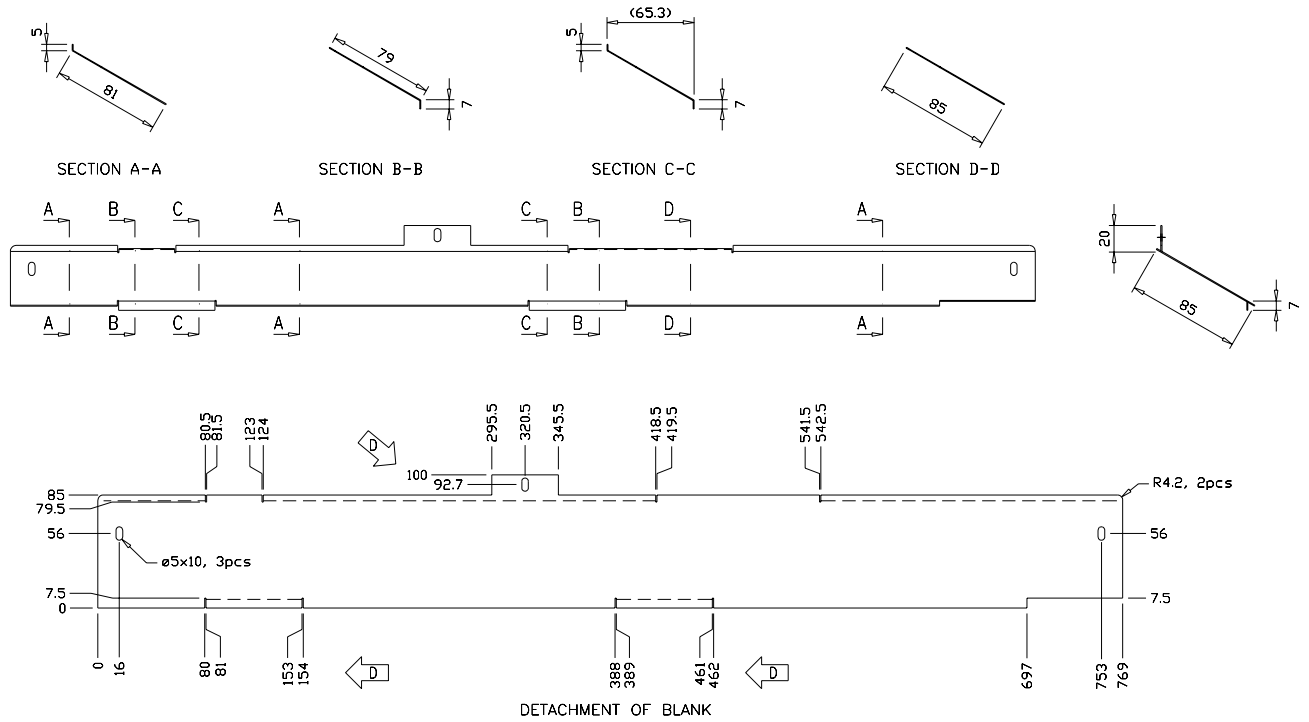


Figure 2-54 The DC busbars (top: +; bottom: -) connecting the R10i/ R11i phase modules. (See Figure 2-55 for the dimensions of the insulator piece.)

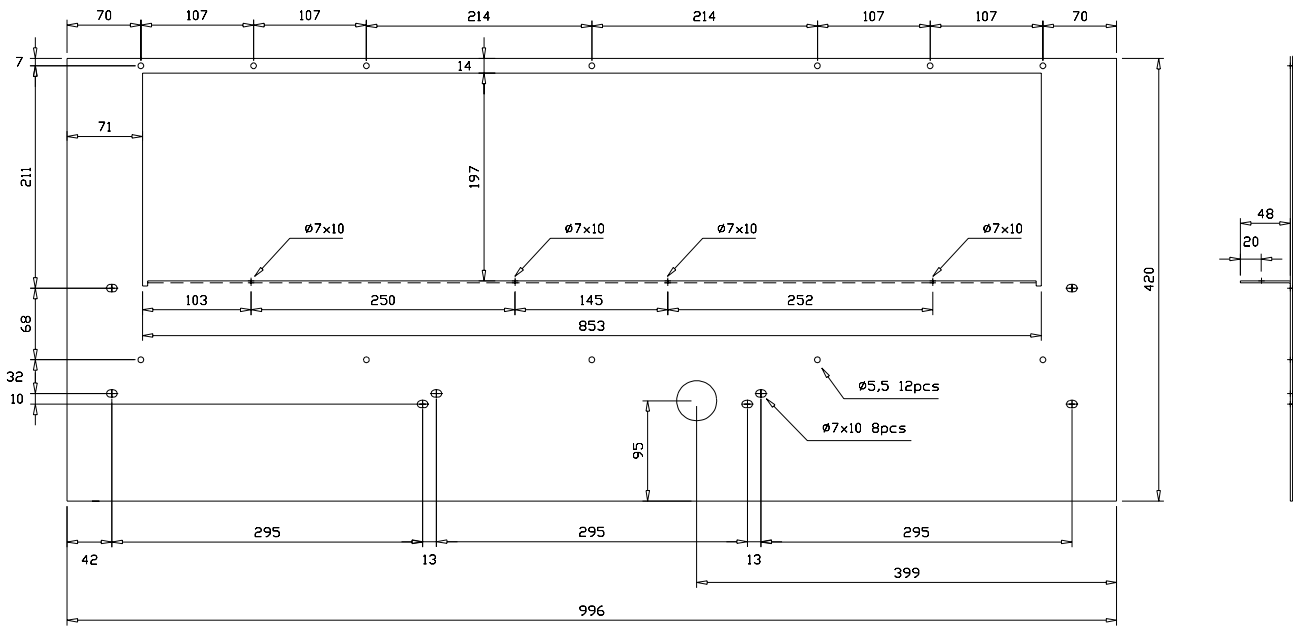




MATERIAL: POLYCARBONATE (PC) SHEET 0,75mm  
 CLEAR, UV STABILITY, ISO 1043  
 (e.g. LEXAN 9030)  
 SIZE: 0.08 m<sup>2</sup>  
 DIMENSION WITHOUT TOLERANCE DIN 6930-m

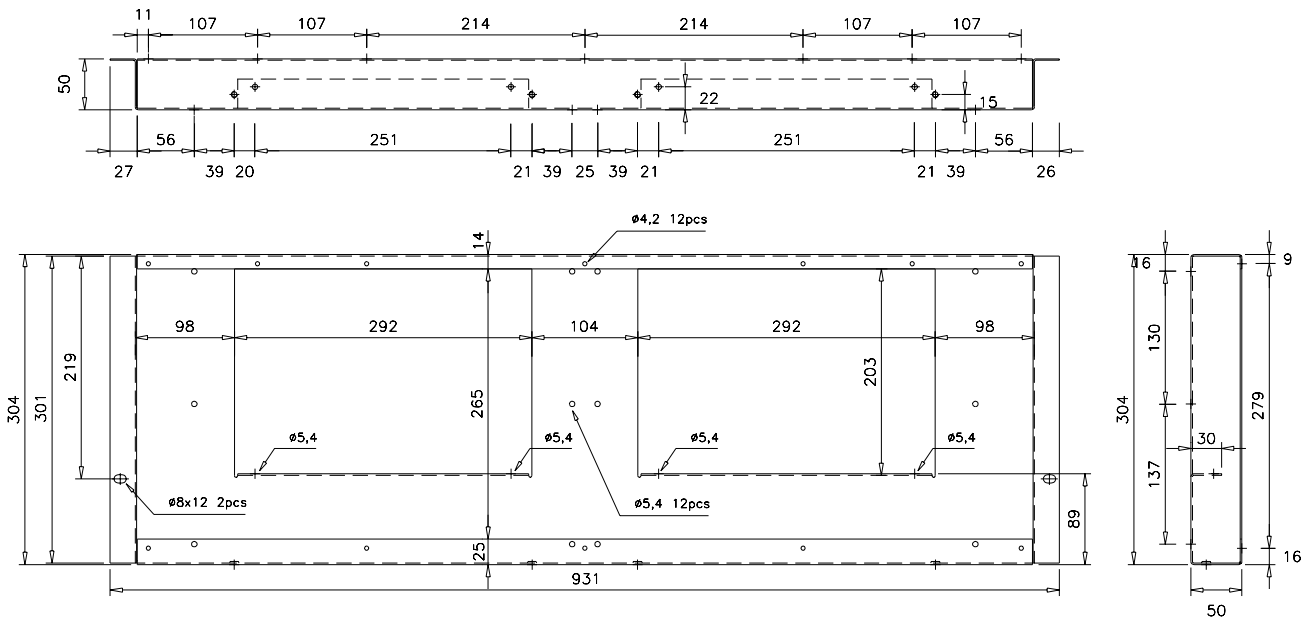
61384553-D

Figure 2-55 Dimensions of the insulator between the R10i/R11i DC busbars.



MATERIAL: HOT-DIP ZINC COATED STEEL SHEET 2mm  
 EN 10142-DX51D+Z275-N-A-C  
 DIMENSION WITHOUT TOLERANCE DIN 6930-m

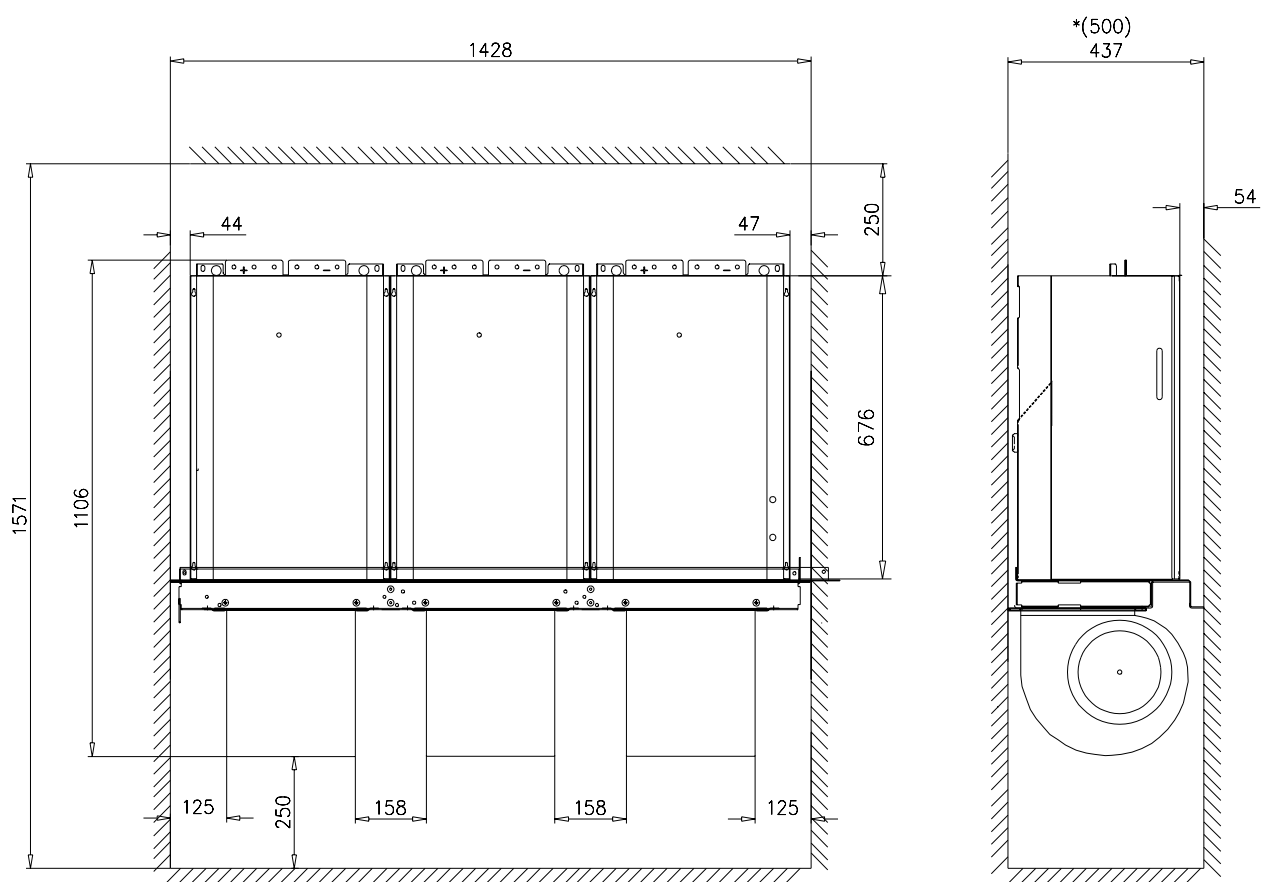
Figure 2-56 Module mounting plate for Frame R10i/R11i modules.



ALL FOLDING RADII R=1,5  
 DIMENSION WITHOUT TOLERANCE DIN 6930-m

Figure 2-57 Fan mounting plate for Frame R10i/R11i modules.

### Frame R12i



**Note:** DC and AC busbars are not included in the dimensions.

\*Typical depth including AC busbars. (See Mounting Frame dimensional drawing)

FRAME SIZE	MODULE TYPE	WEIGHT (kg)
R12	ACN 634-0935-3	195
	ACN 634-1125-3	201
	ACN 634-1095-5	207
	ACN 634-1385-5	216
	ACN 634-1045-6	207
	ACN 634-1385-6	216

Figure 2-58 Frame R12i module dimensions and clearances.

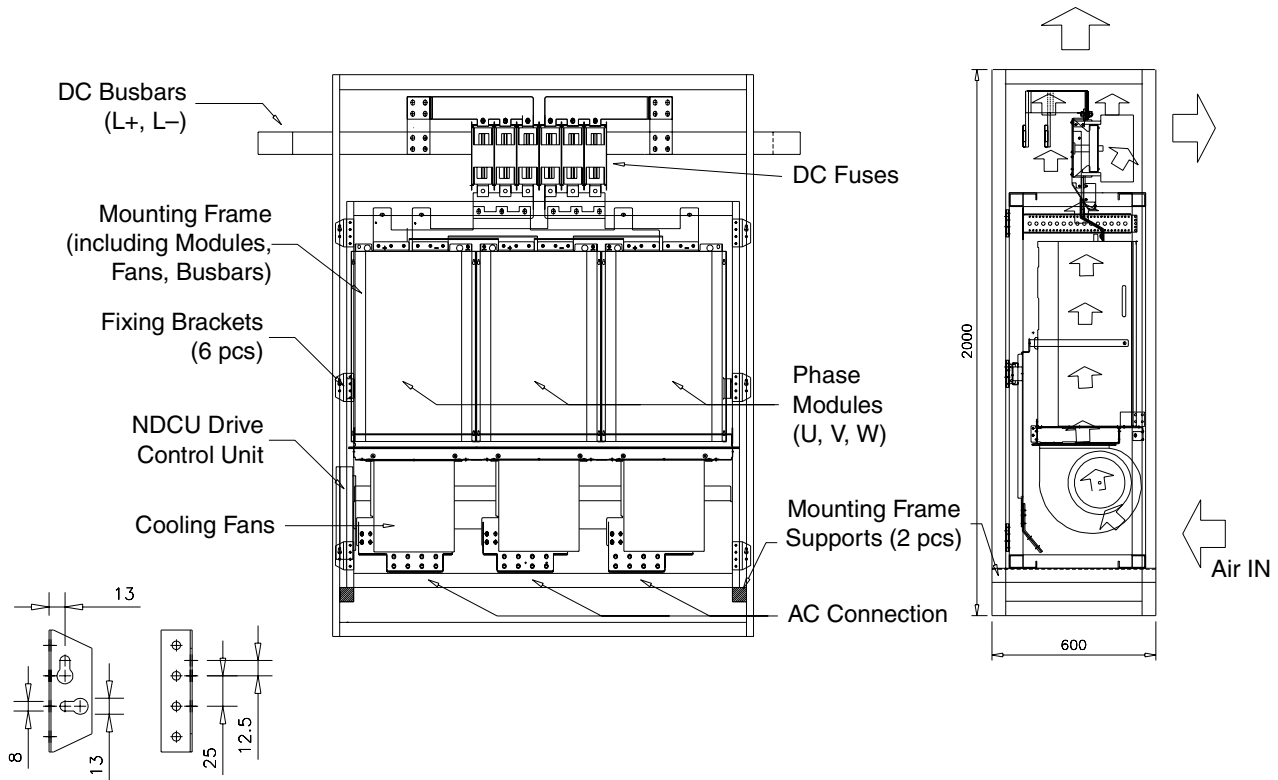
*Installation Using the Mounting Frame*

Frame R12i modules are most conveniently installed using the mounting frame available in the ACS 600 MultiDrive Modules product line. The mounting frame stands on supports fastened to the cabinet, and is fixed to the rear wall of the cabinet at 6 points with the brackets included. The frame has mounting holes pitched at 25 mm.

An air baffle has to be used for preventing air recirculation if the cabinet is wider or deeper than the mounting frame.

Busbars are used for both the DC and AC connections. The DC connectors (3 points per leg) are located at the top of the module, the AC connectors at the bottom below the cooling fans.

The phase modules are installed in the mounting frame in similarly to R10i/R11i. See page 2-68.

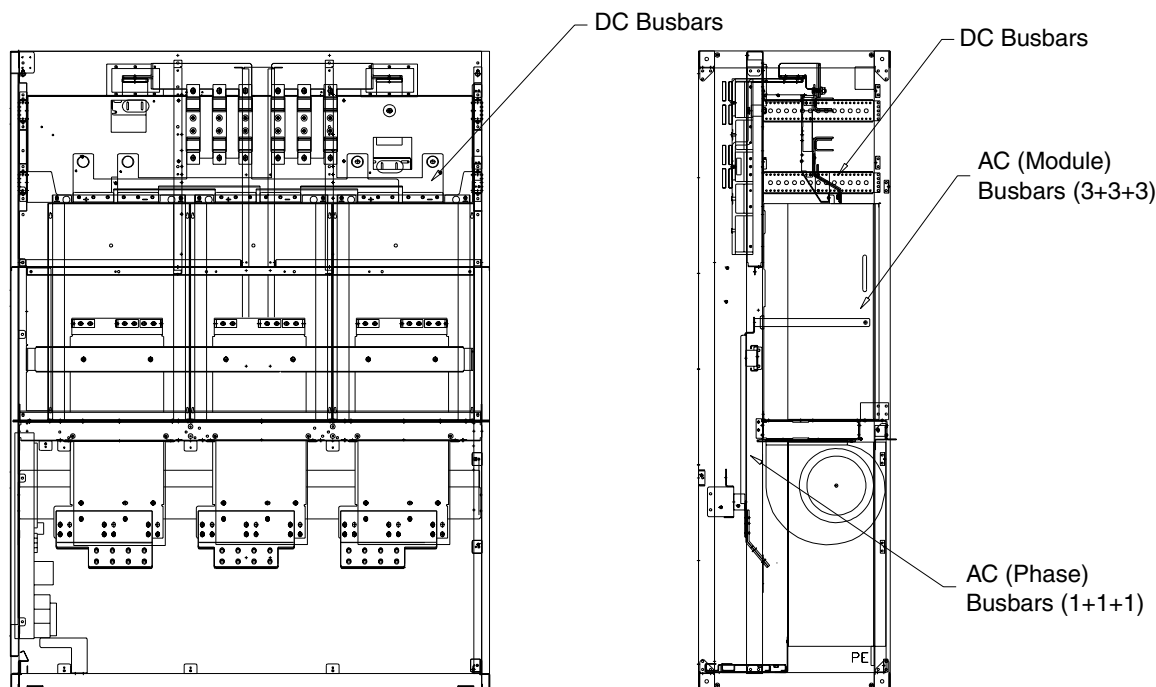


*Figure 2-59 Cabinet layout example for R12i modules – Installation using the mounting frame.*

*Installation without the Mounting Frame*

If the mounting frame is not used, these issues must be considered:

- The DC bus between the phase modules must have a low inductance. Therefore it is strongly recommended to construct the connecting busbars (and the insulator) exactly as shown in the drawings below.
- Air recirculation inside the cabinet must be prevented. The module mounting plate (shown in Figure 2-65) can also be used as an air baffle by increasing its total width and depth. Alternatively, a separate air baffle can be used.
- The space between the cooling fans and the phase modules must be as shown in the diagrams below to ensure even distribution of cooling air between the modules. Constructing a fan mounting plate like the one presented in Figure 2-66 is recommended.
- The clearances shown in Figure 2-58 must be observed. Special attention must be paid to the length of the additional AC busbars inside the phase modules – a sufficient clearance must be left between the busbar and the inside of the module front cover.
- The three AC busbars of each phase module must be connected together as close to the module as possible to avoid differential currents. Using the busbars shown in the drawings below is recommended.



*Figure 2-60 R12i installation without the mounting frame.*

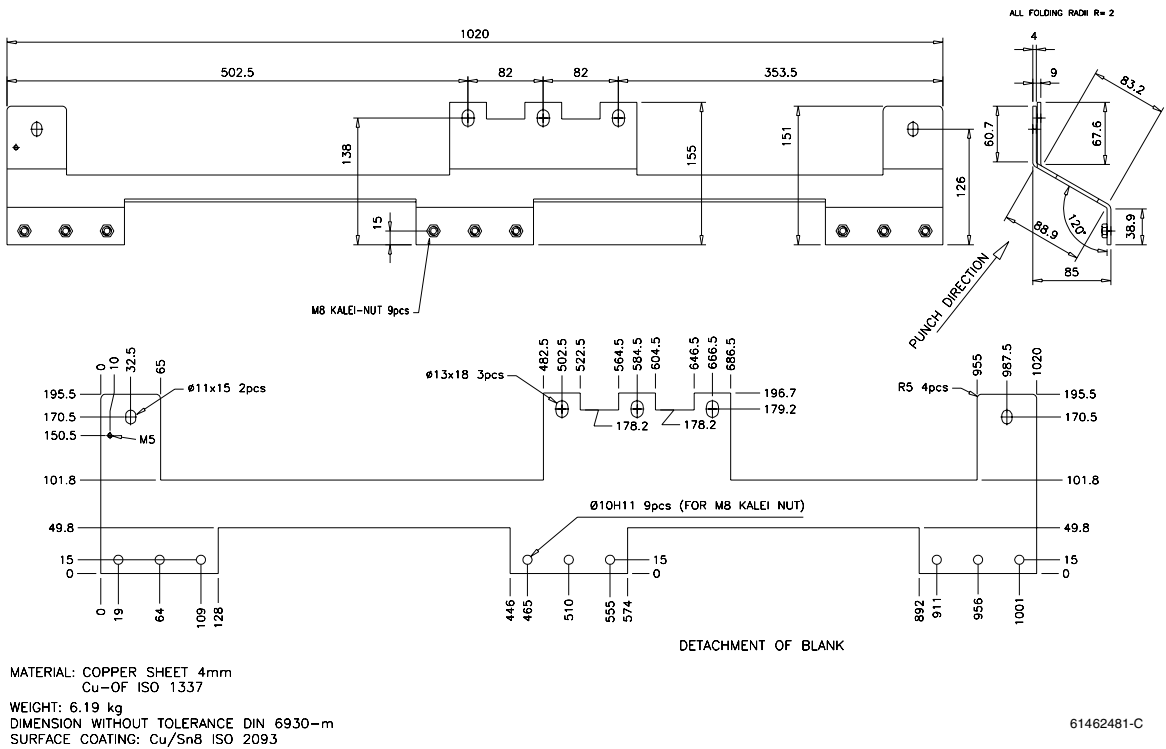
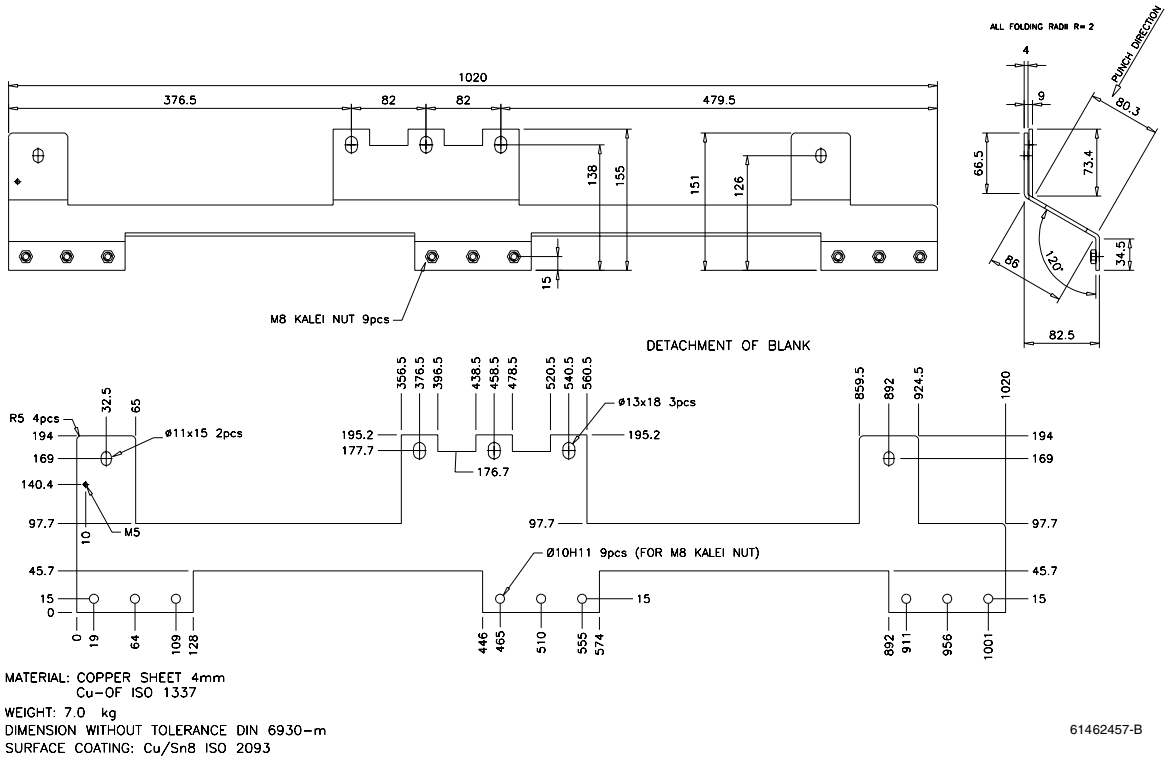


Figure 2-61 The DC busbars (top: +; bottom: -) connecting the R12i phase modules. (See Figure 2-62 for the dimensions of the insulator piece.)

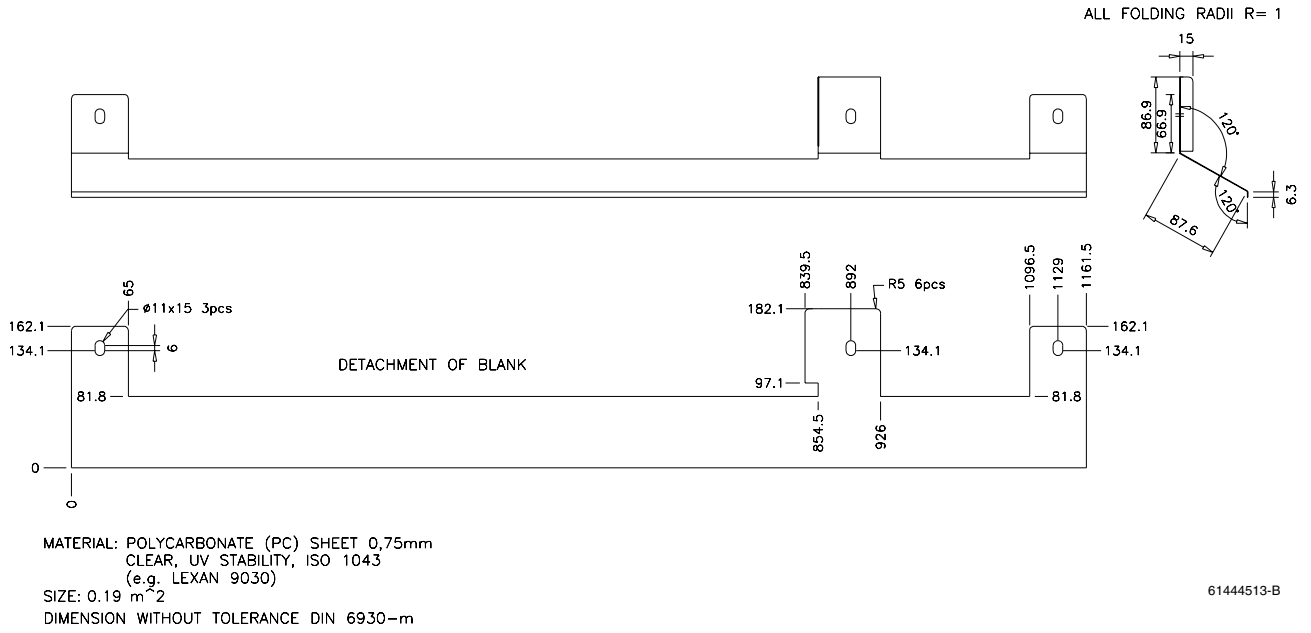


Figure 2-62 Dimensions of the insulator between the R12i DC busbars.

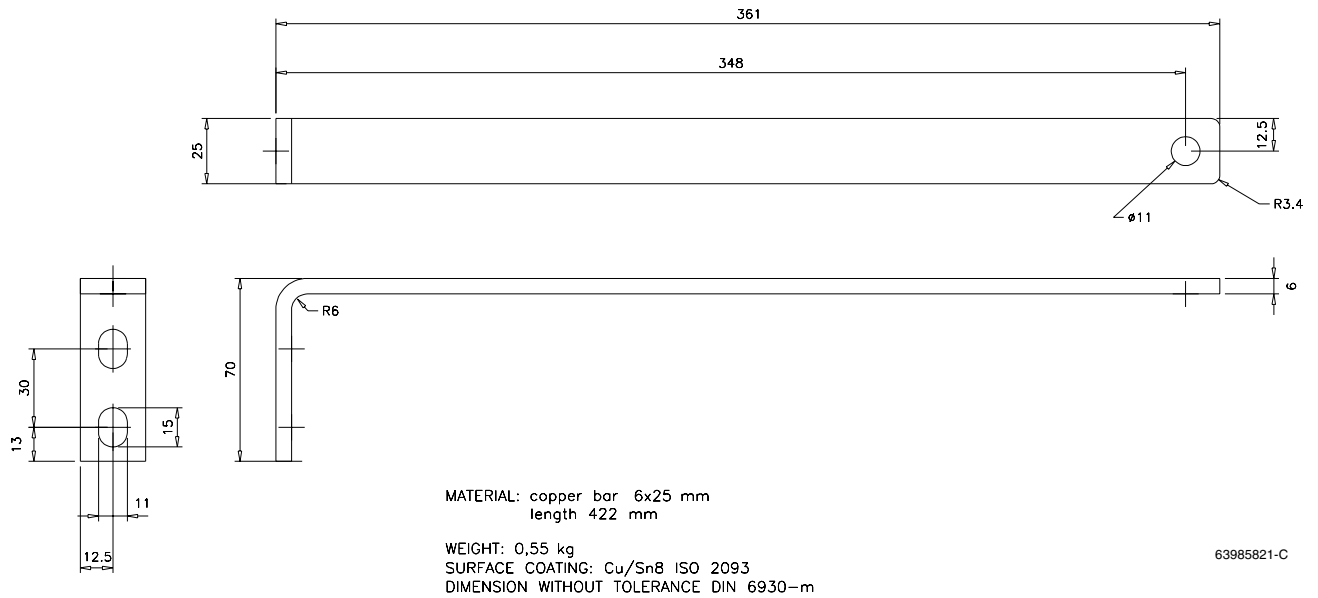
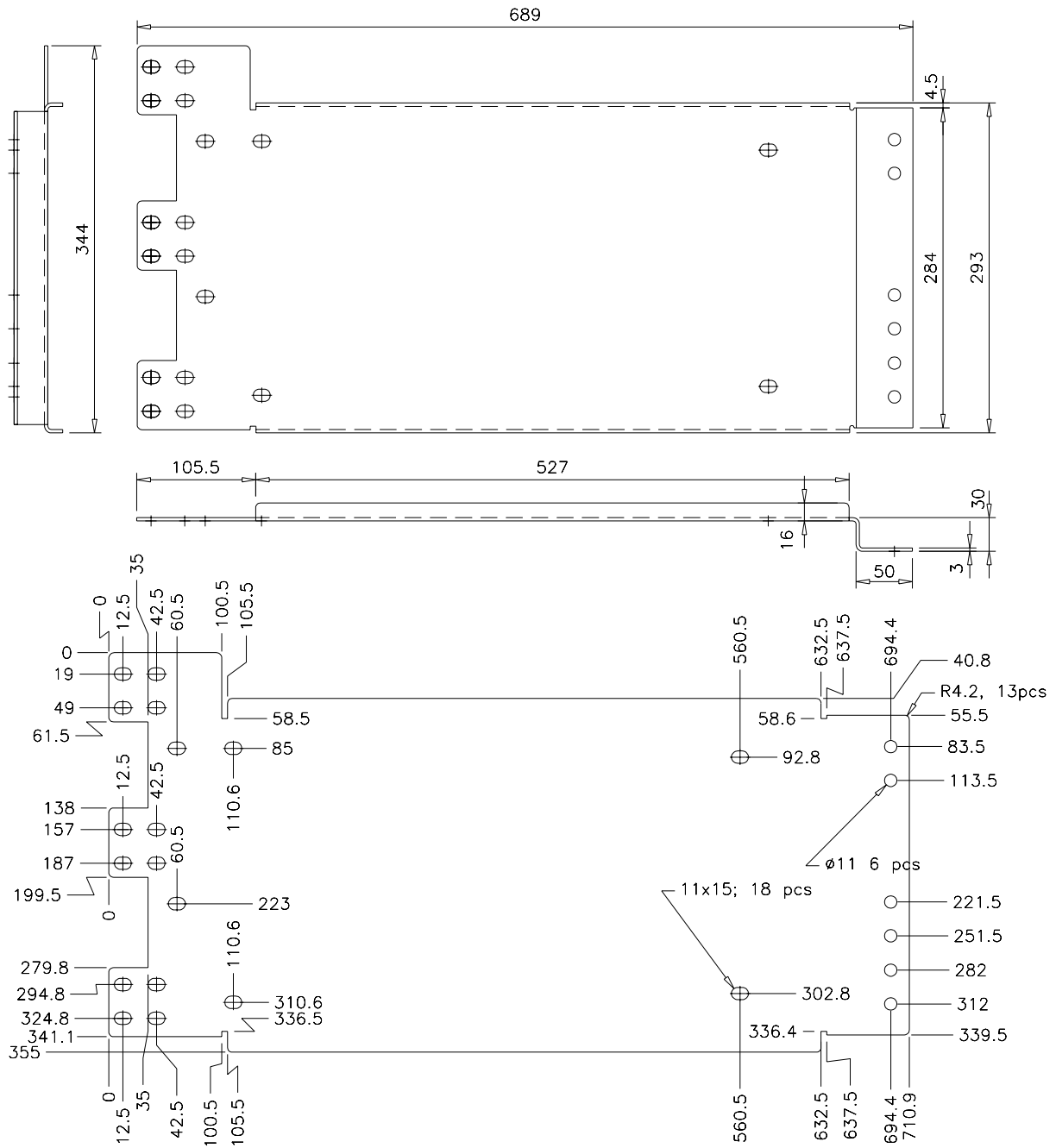


Figure 2-63 R12i AC (Module) busbar dimensions.



63985791-E

Figure 2-64 R12i AC (Phase) busbar dimensions.



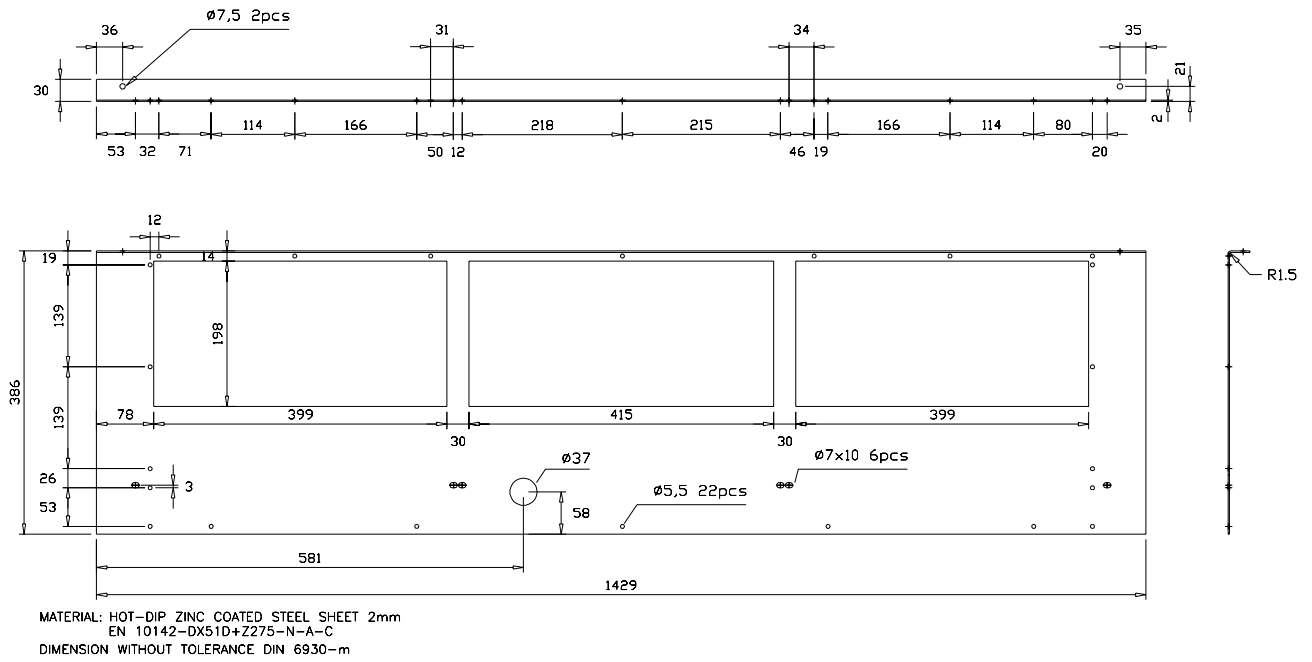


Figure 2-65 Module mounting plate for Frame R12i modules.

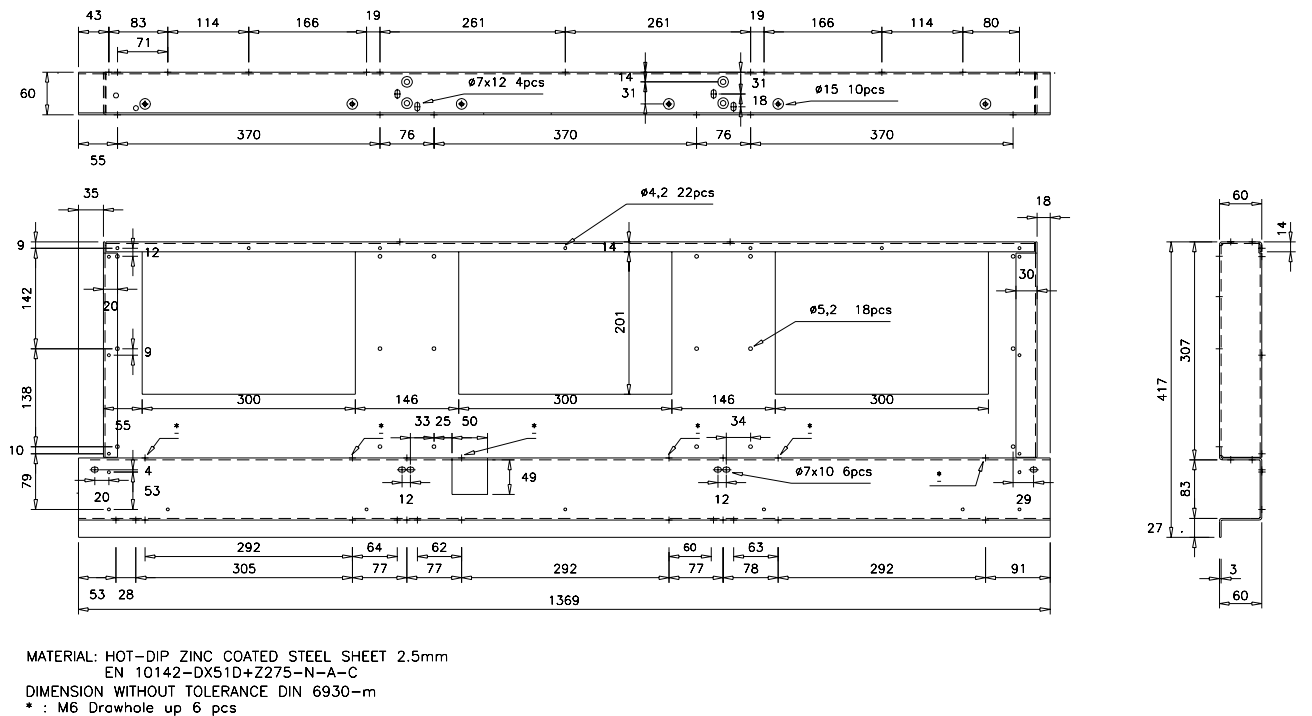


Figure 2-66 Fan mounting plate for Frame R12i modules.

## Common Mode Filters

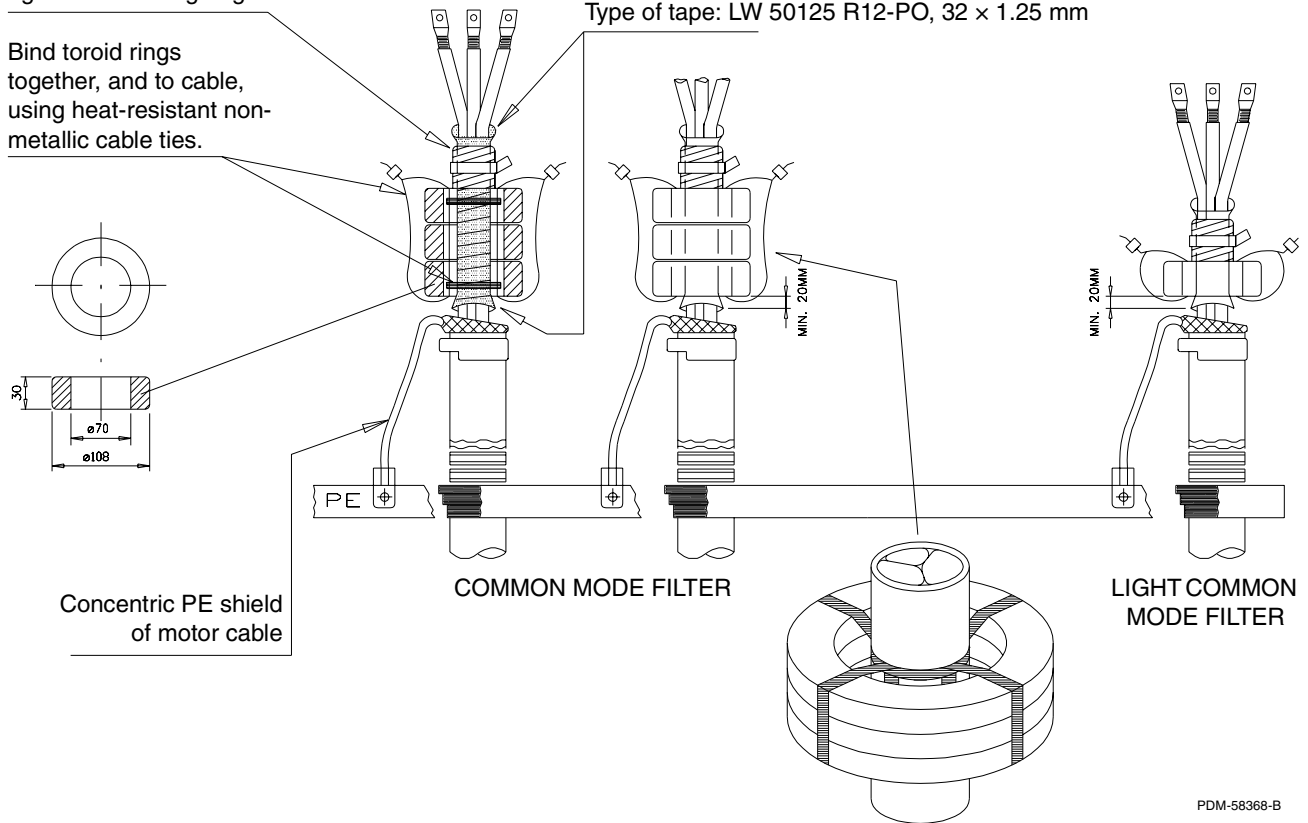
The figure below illustrates how Common Mode Filters and Light Common Mode Filters are installed onto the motor cables.

Tie conductors tightly together using non-conductive electrical tape plus non-metallic cable tie to prevent damage to insulation due to rubbing against toroid ring edge.

Bind toroid rings together, and to cable, using heat-resistant non-metallic cable ties.

In order to provide thermal insulation for conductors, wrap cables inside toroid rings with silicon rubber tape. Each turn of tape should overlap half of previous turn. Approximately 1.5 metres of tape is needed per cable.

Type of tape: LW 50125 R12-PO, 32 x 1.25 mm



PDM-58368-B

## Dynamic Braking Units

### Braking Chopper Cubicle

The braking chopper and cooling fan are to be installed as shown below. It is important that the chopper and fan are positioned exactly as illustrated in relation to each other.

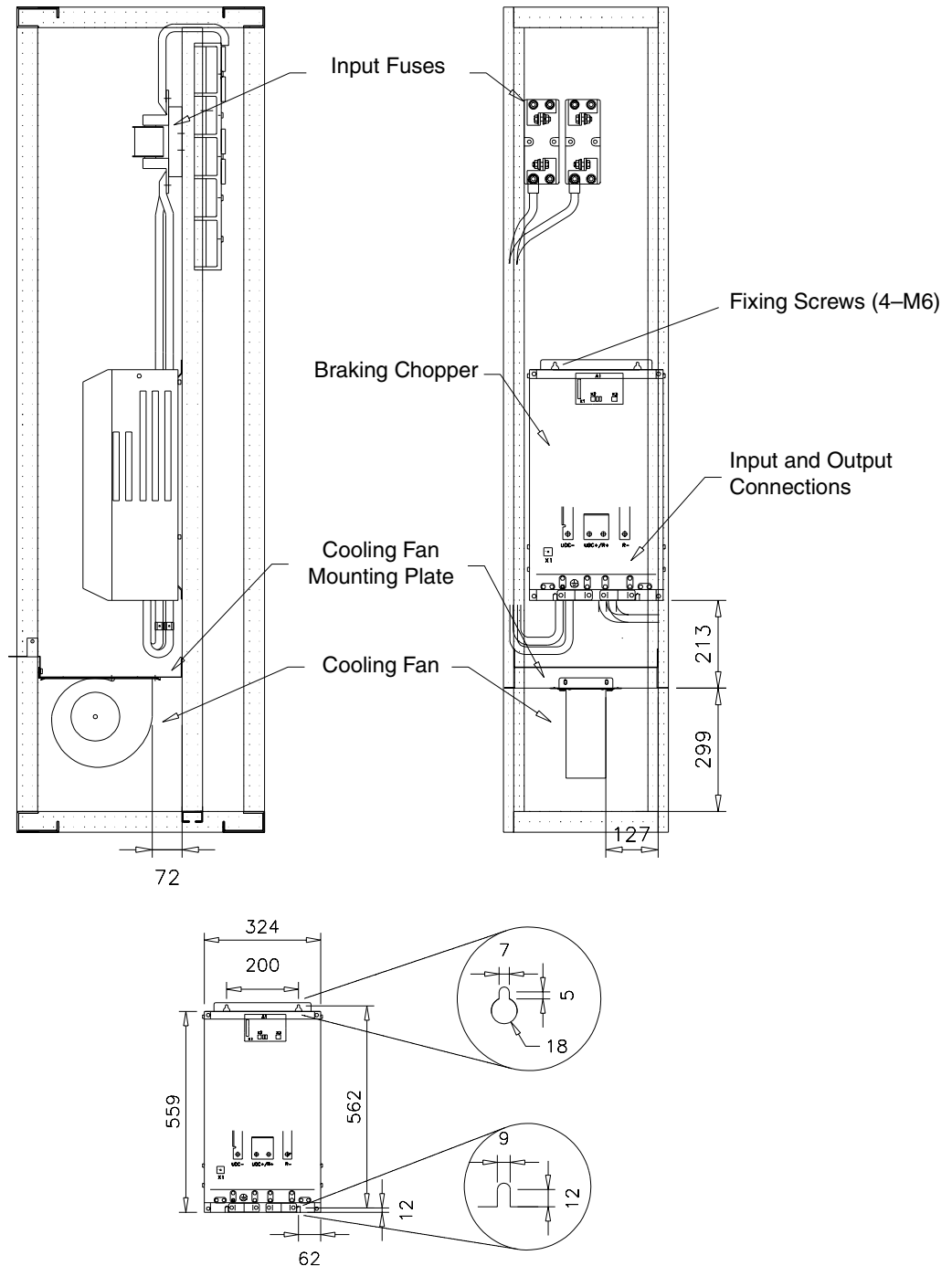
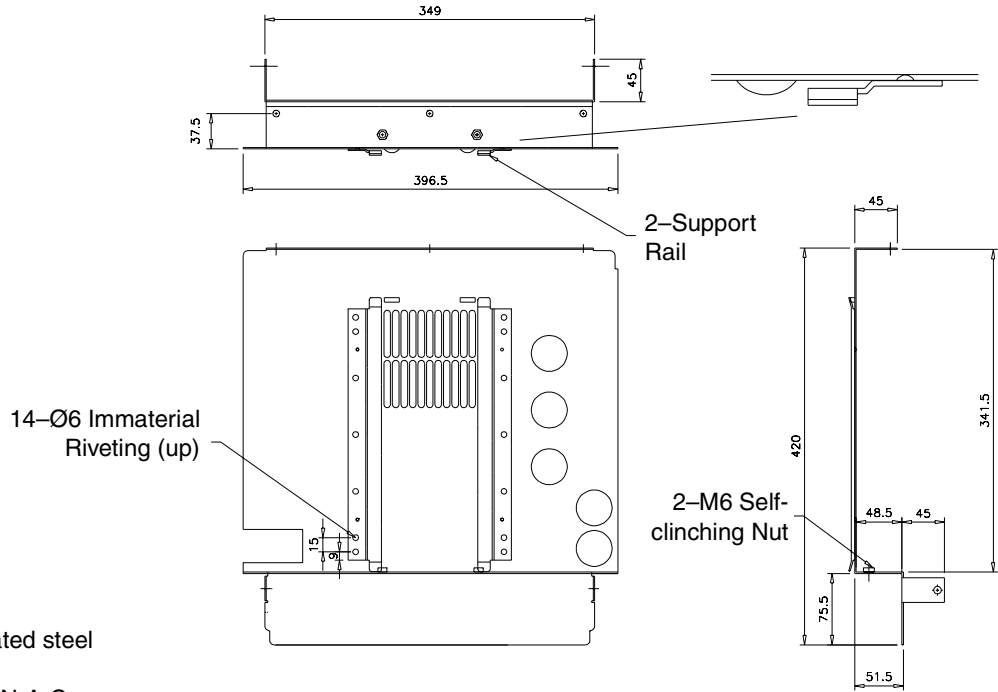
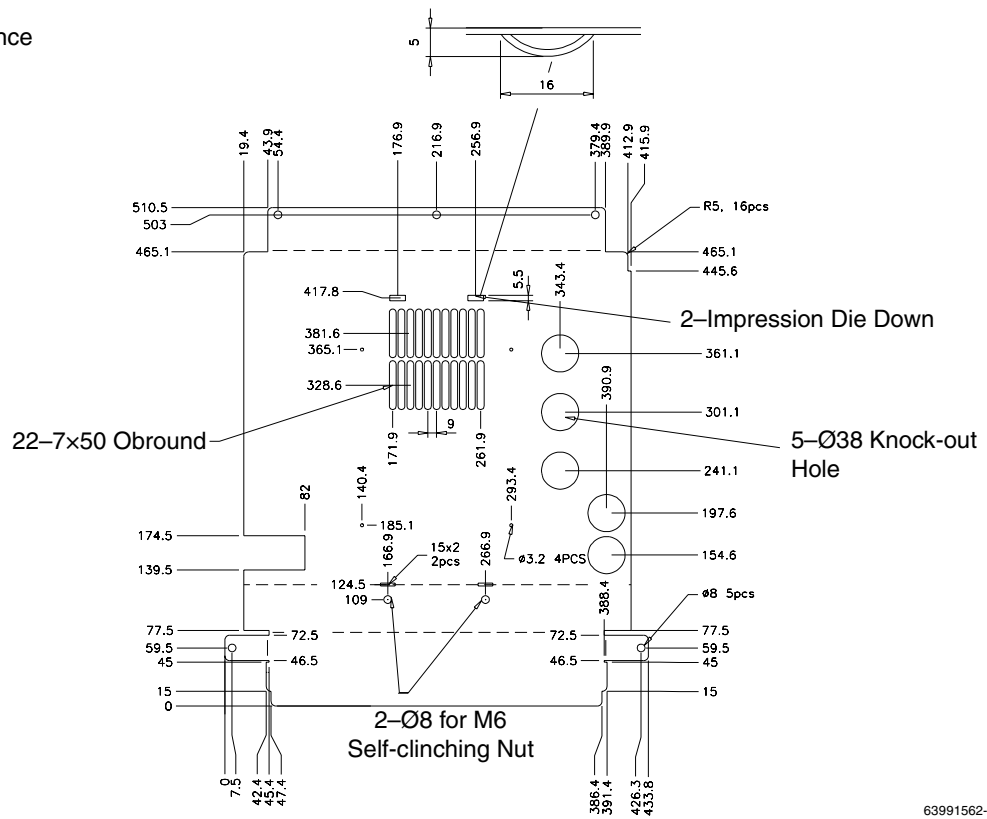


Figure 2-67 Braking chopper and cooling fan installation.

The braking chopper is fastened to the rear wall using four M6 screws.  
The cooling fan is fixed to a separate mounting plate pictured below.

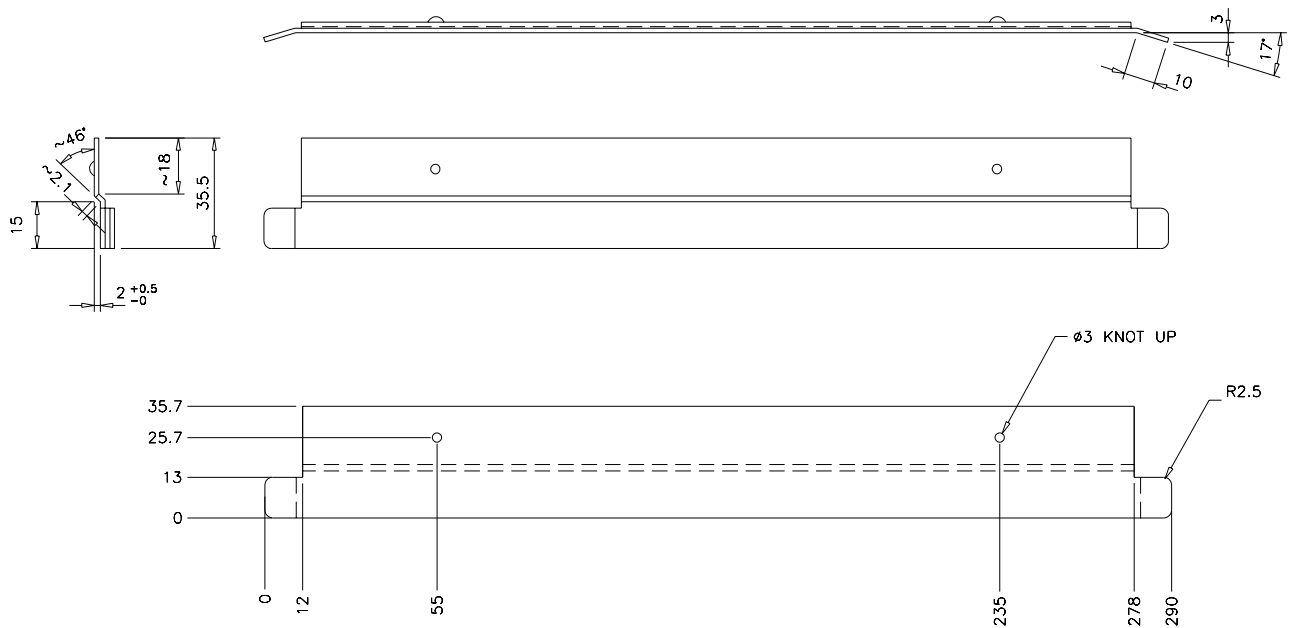


Material: Hot-dip zinc coated steel sheet 1.5 mm  
EN 10142-DX51D+Z275-N-A-C  
Weight: 2.67 kg  
Dimension without tolerance  
DIN 6930-m



63991562-B

Figure 2-68 Mounting plate for chopper cooling fan.



Material: Hot-dip zinc coated steel sheet 1.5 mm  
 EN 10142-DX51D+Z275-N-A-C  
 Weight: 0.13 kg  
 Dimension without tolerance DIN 6930-m

63991589

Figure 2-69 Support rail for chopper cooling fan.

**Resistor Cubicle**

Two mounting rails (upper and lower) are fastened to the rear wall of the cabinet using four M6 screws per rail. Each braking resistor is fixed to the rails using four M6 screws.

The cooling fan is installed using a separate mounting plate pictured below. It is essential to prevent the cooling air from circumventing the resistors. The resistors and fan must be positioned exactly as illustrated in relation to each other.

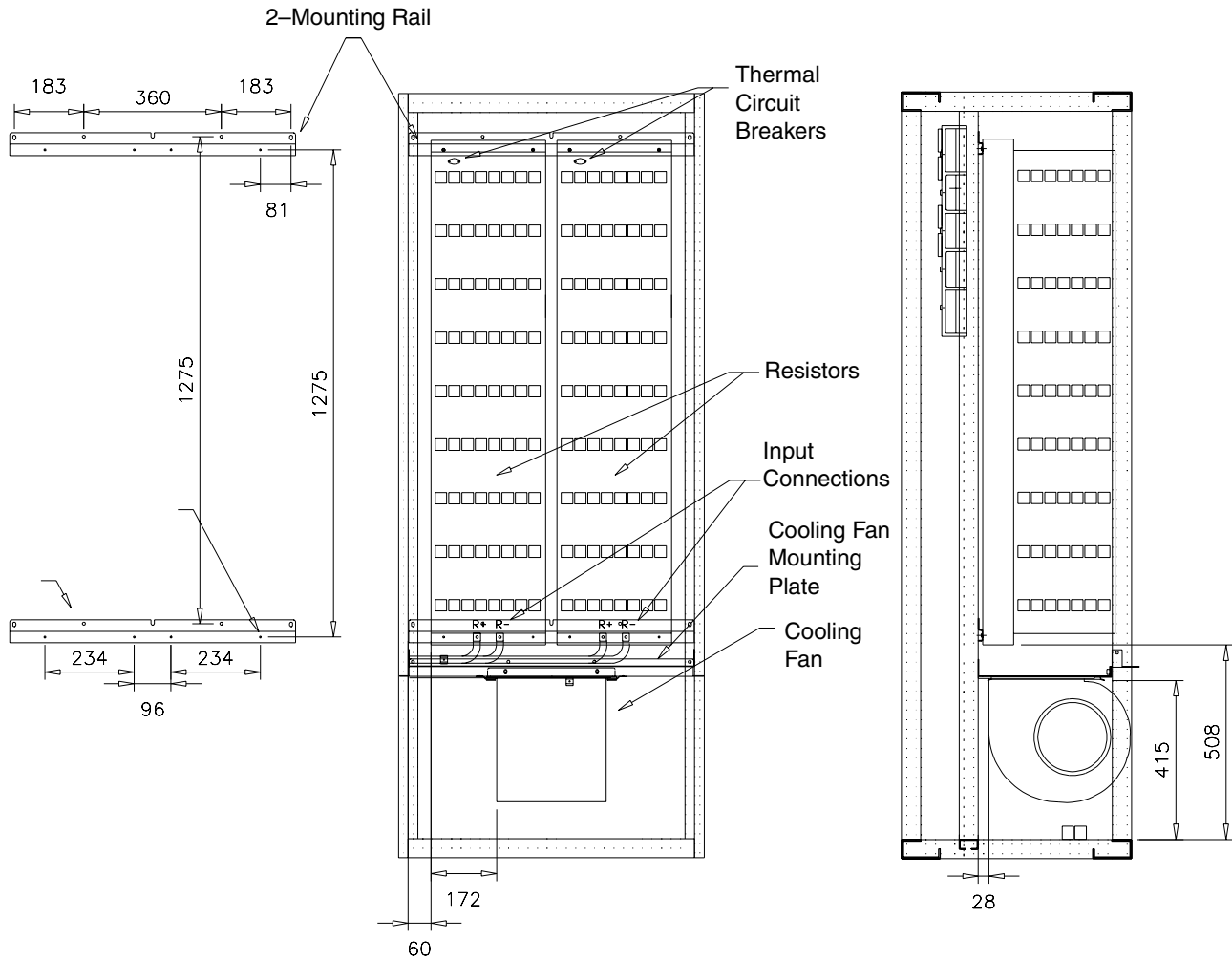
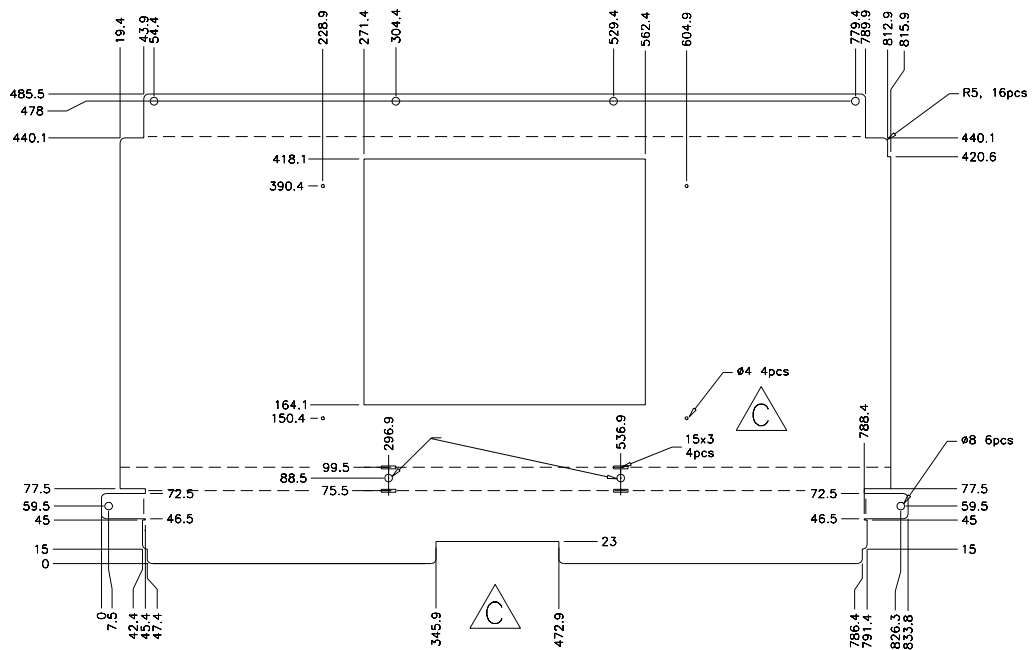
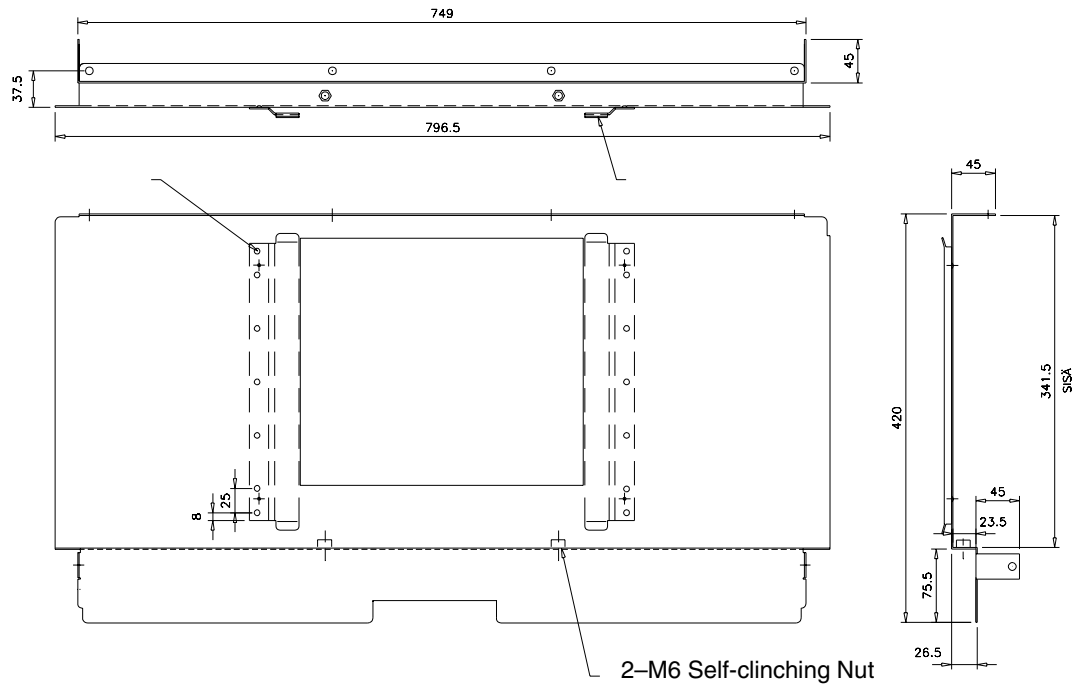


Figure 2-70 Braking resistor and cooling fan installation.



Material: Hot-dip zinc coated steel sheet 1.5 mm  
 EN 10142-DX51D+Z275-N-A-C  
 Weight: 4.63 kg  
 Dimension without tolerance DIN 6930-m

61425705-C

Figure 2-71 Mounting plate for resistor cooling fan.

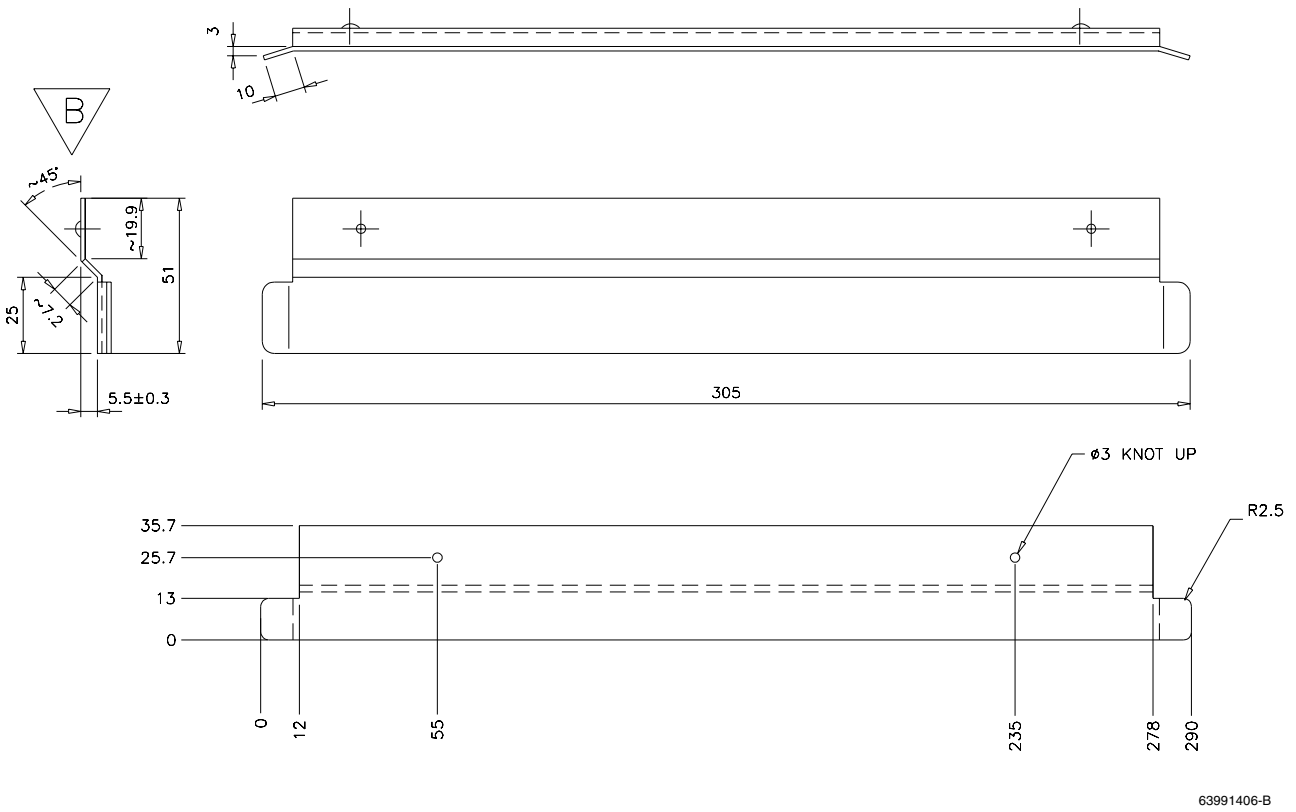


Figure 2-72 Support rail for resistor cooling fan.

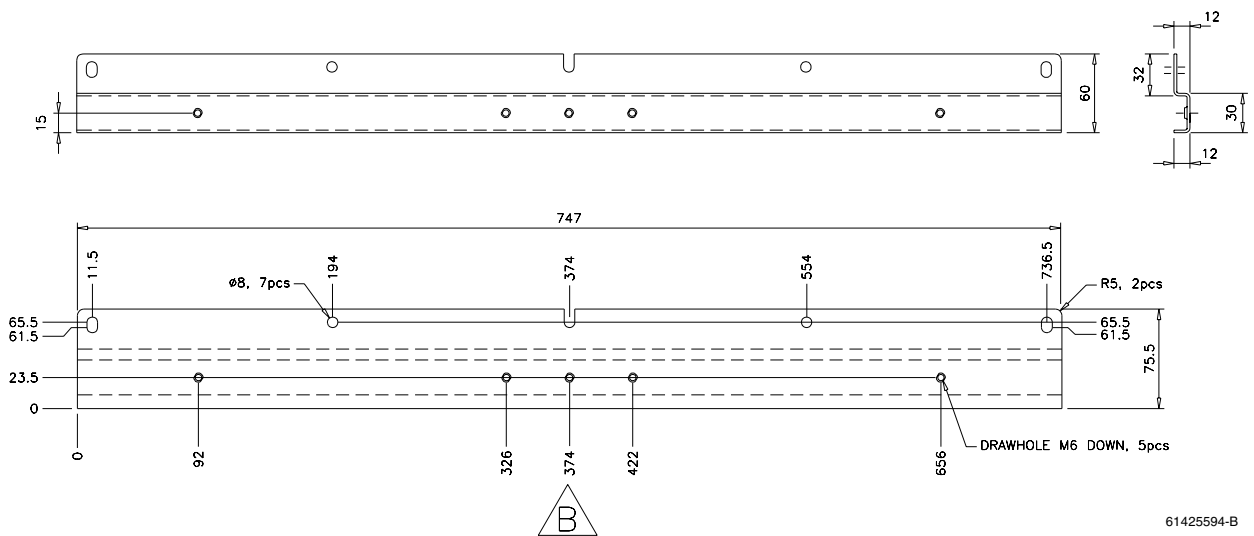


Figure 2-73 Mounting rail for resistors.



### Overview

This chapter contains wiring examples that can be used as a basis for constructing the control wiring for the drive system.

### Precautions



---

**WARNING!** Circuit boards contain components sensitive to electrostatic discharge (ESD). Wear an earthing wrist band when handling the boards. Do not touch the boards unnecessarily.

---

### Notes on Optical Components

Handle fibre optic cables with care. When unplugging optic cables, always grab the connector, not the cable itself. Do not touch the ends of the fibres with bare hands as the fibre is extremely sensitive to dirt. The specifications of the optic cable are as follows:

- Storage temperature: -55 ... +85 °C
- Installation temperature: -20 ... +70 °C
- Maximum short-term tensile force: 50 N
- Minimum short-term bend radius: 25 mm
- Minimum long-term bend radius: 35 mm
- Maximum long-term tensile load: 1 N
- Flexing: Max. 1000 cycles

ABB drive products in general utilise 5 and 10 MBd (megabaud) optical components from Agilent Technologies' (Hewlett-Packard) Versatile Link range. Please note that the optical component type is not directly related to the actual communication speed.

---

**Note:** The optical components (transmitter and receiver) on a fibre optic link must be of the same type.

---

Plastic optical fibre (POF) cables can be used with both 5 MBd and 10 MBd optical components. 10 MBd components also enable the use of Hard Clad Silica (HCS<sup>®</sup>) cables, which allow longer connection distances thanks to their lower attenuation. HCS<sup>®</sup> cables cannot be used with 5 MBd optical components.

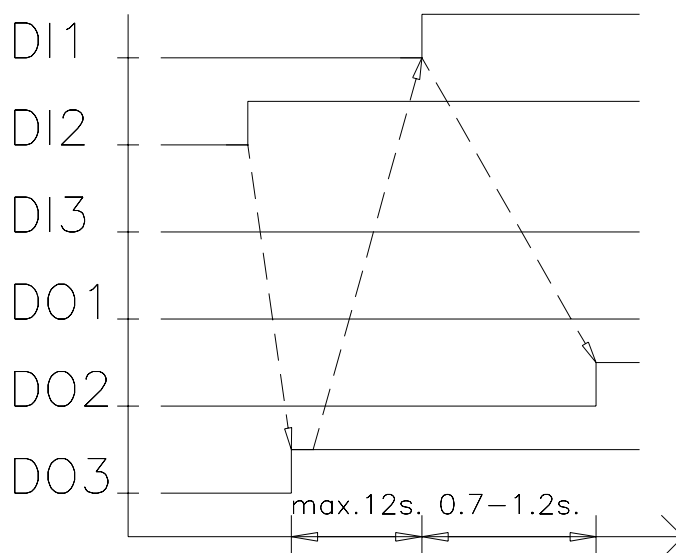
The maximum lengths of fibre optic links for POF and HCS<sup>®</sup> cables are 20 and 50 metres respectively.

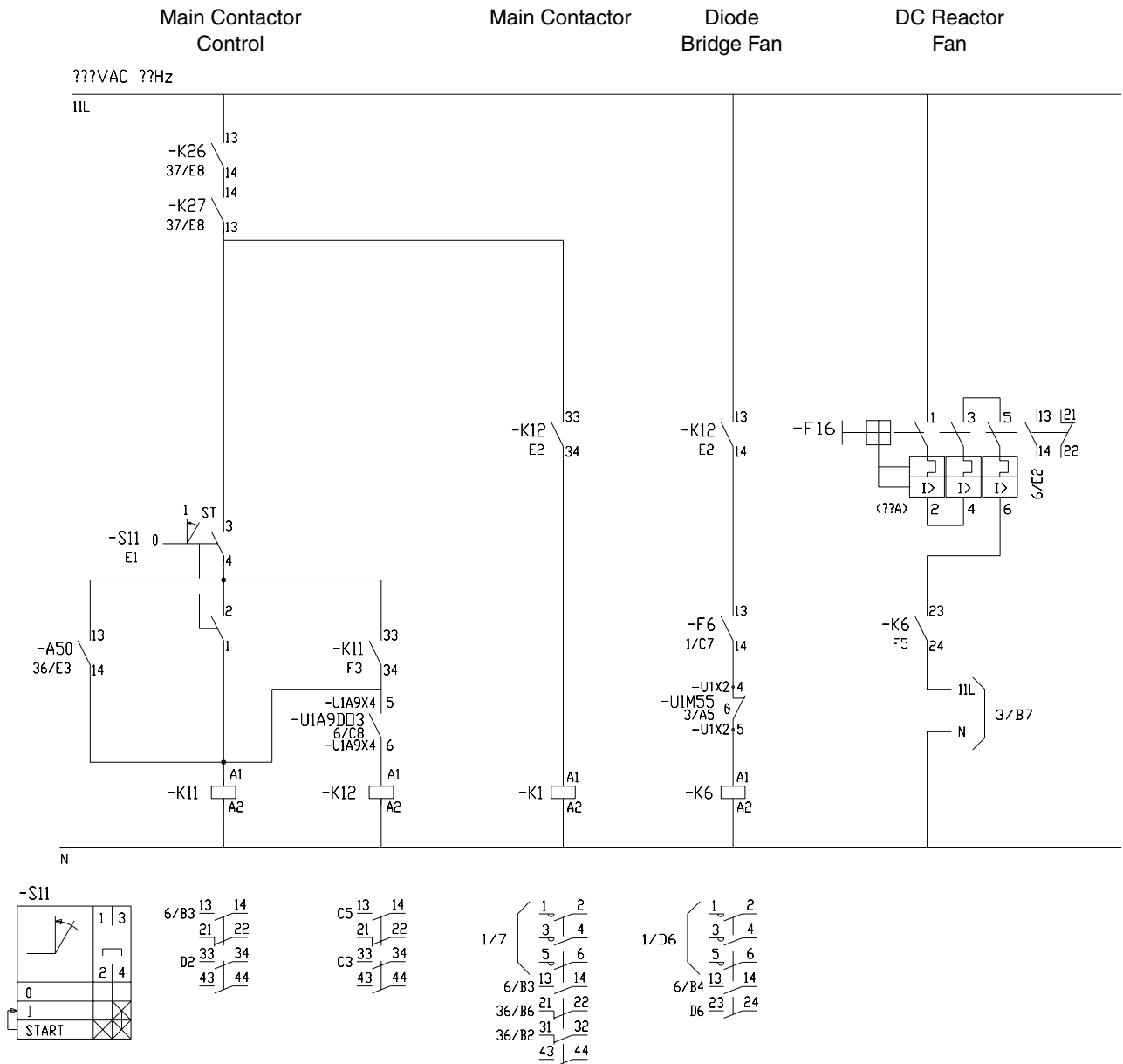
HCS<sup>®</sup> is a trademark of SpecTran Corporation.

**Diode Supply Unit  
Control Wiring**

The assignments of the digital inputs and outputs of the diode supply unit (DSU) are shown below, together with a timing diagram. For further information on the DSU, refer to the *Diode Supply Units (DSU) User's Manual*.

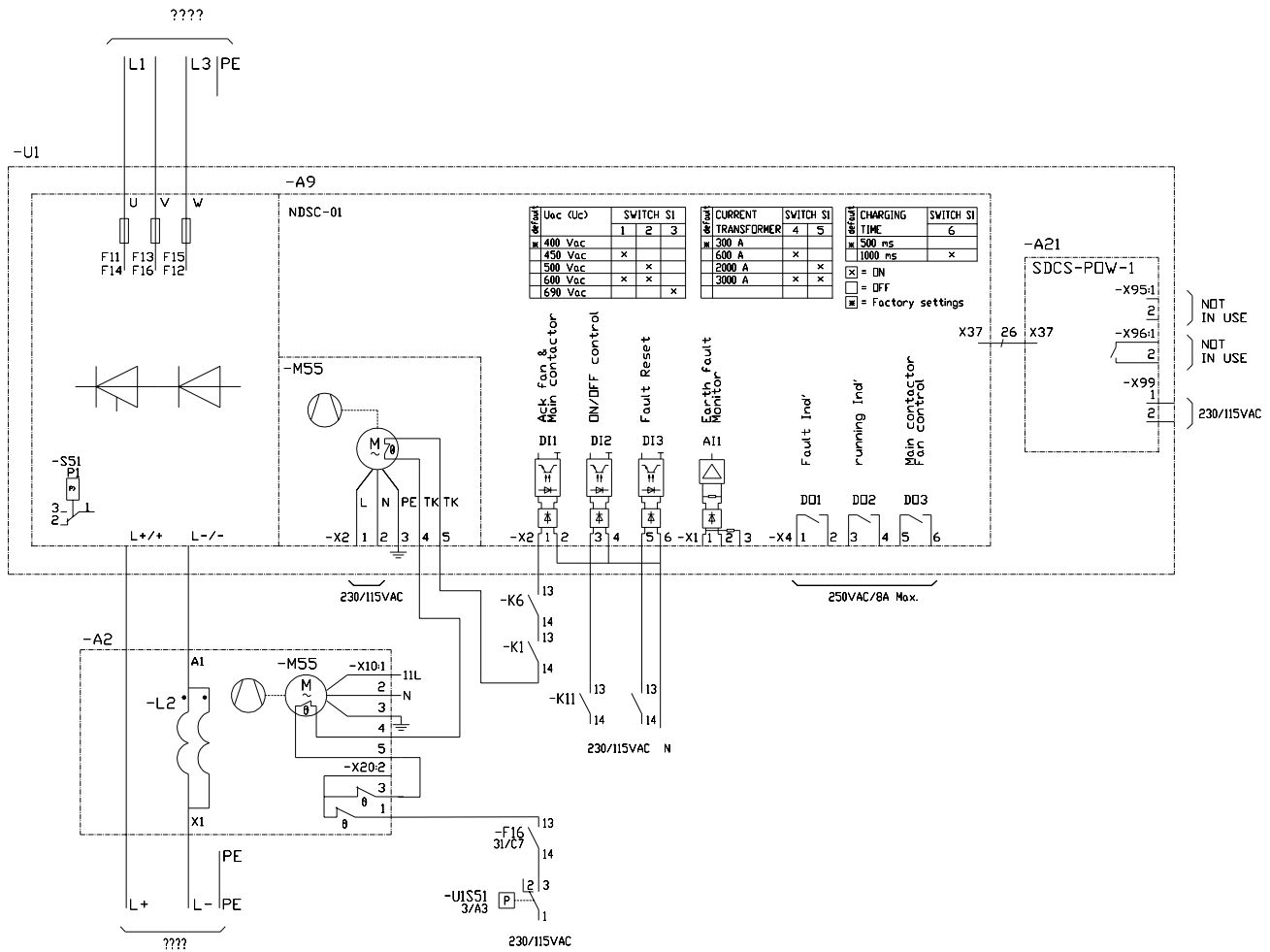
Input/Output	Assignment/Information
DI1	<i>Fan and main contactor acknowledge, fan temperature protection, fan circuit breaker acknowledge, pressure switch, DC reactor fan and DC reactor temperature protection</i> This input is used for monitoring the above equipment. (Starting the supply unit is only possible when this input is 1.) 0 = Fan not rotating, main contactor open, etc. 1 = Fan rotating, main contactor closed, etc.
DI2	<i>ON/OFF Control</i> 0 = Stop 0 → 1 = Run
DI3	<i>Reset</i> 0 → 1 = Reset
DO1	<i>Fault</i> 0 = No fault 1 = Fault present
DO2	<i>Running</i> 0 = DSU not modulating or charging 1 = DC link charged, DSU operating
DO3	<i>Main Contactor Control</i> 0 = Open main contactor 1 = Close main contactor





**Description** The ON signal on DI2 is generated by switch S11, whose START position activates K11 and its hold circuit. A50 (reset) is activated by the EMS (Emergency Stop) circuitry, of which contactors K26 and K27 are part.

Digital output DO3 activates K12 and the main contactor is closed. The cooling fans are started via K6 (which also controls the supply unit fan contactor not presented in this diagram).



**Description** DI1 feedback passes through auxiliary contacts of K6 and K1. This loop also includes all thermal switches (bridge and DC reactor fans, DC reactor coils), DC reactor fan mini-circuit breaker, and the bridge pressure relay (B4 and B5 only).

The ON/OFF signal on DI2 is controlled by an auxiliary contact of K11.

The reset signal is normally received from a reset circuit in the Emergency Stop circuitry.

### Thyristor Supply Unit

#### Connecting the Circuit Boards

The figure below shows the connections between the printed circuit boards.

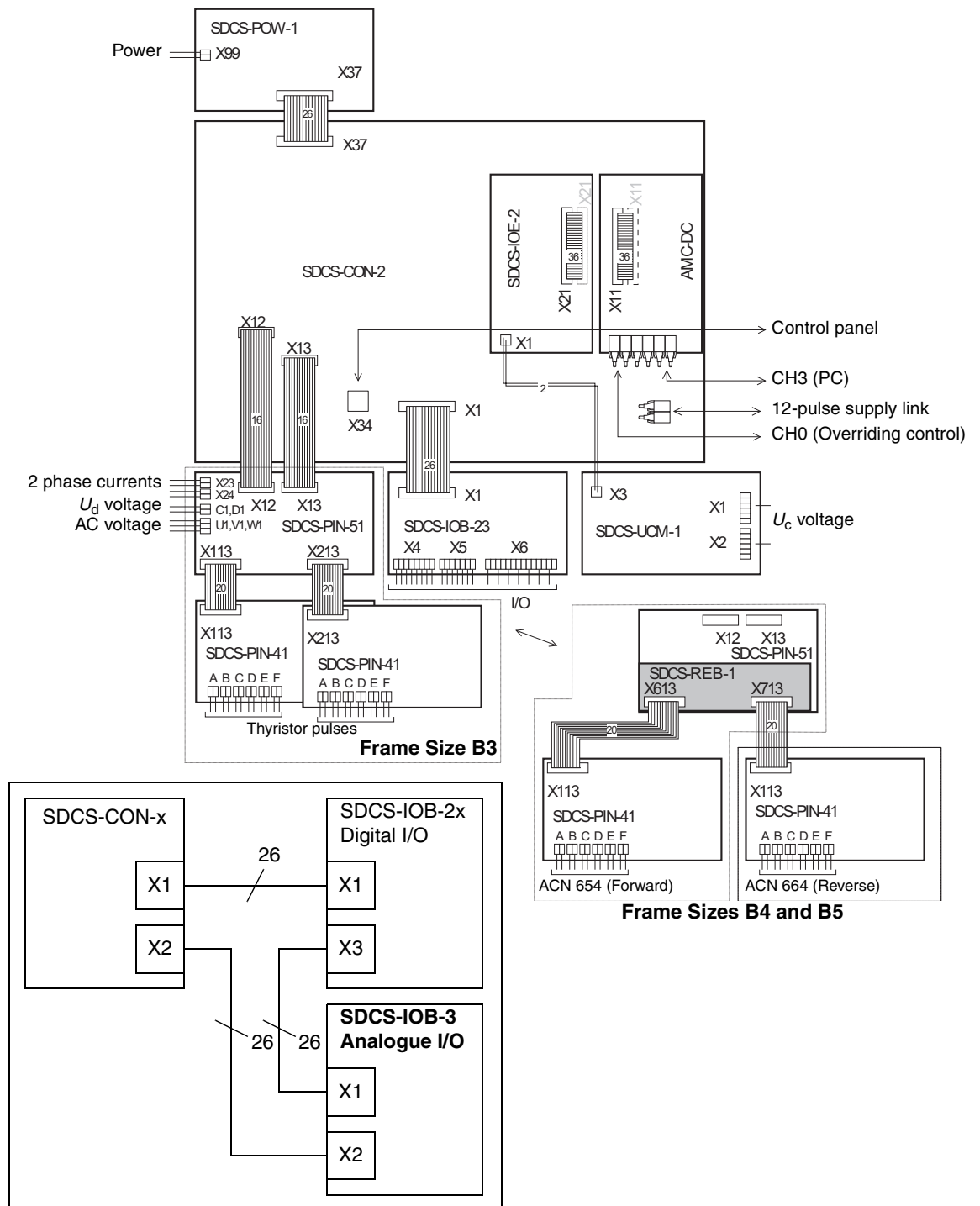
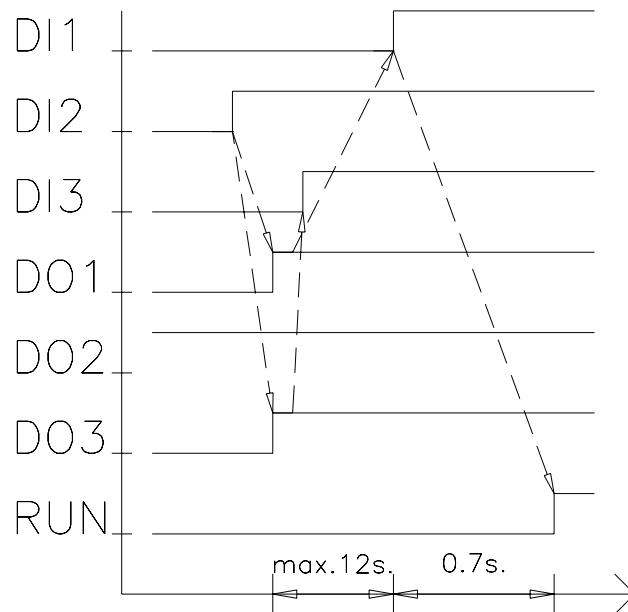
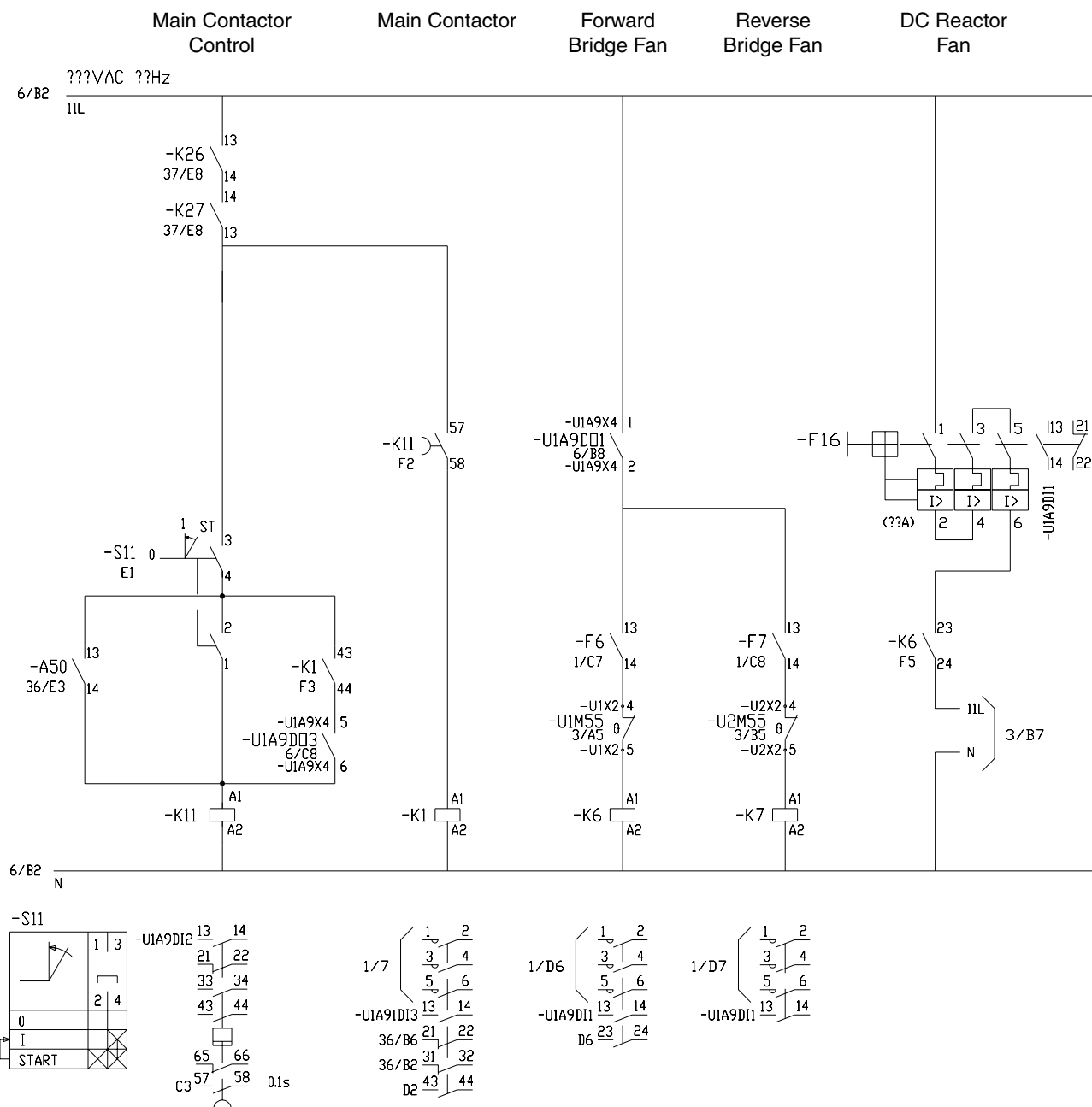


Figure 3-1 TSU board connections. Connection of optional analogue I/O board SDCS-IOB-3 (inset).

**Control Wiring** The assignments of the digital inputs and outputs of the thyristor supply unit (TSU) are shown below, together with a timing diagram. For further information on the TSU, refer to its user documentation.

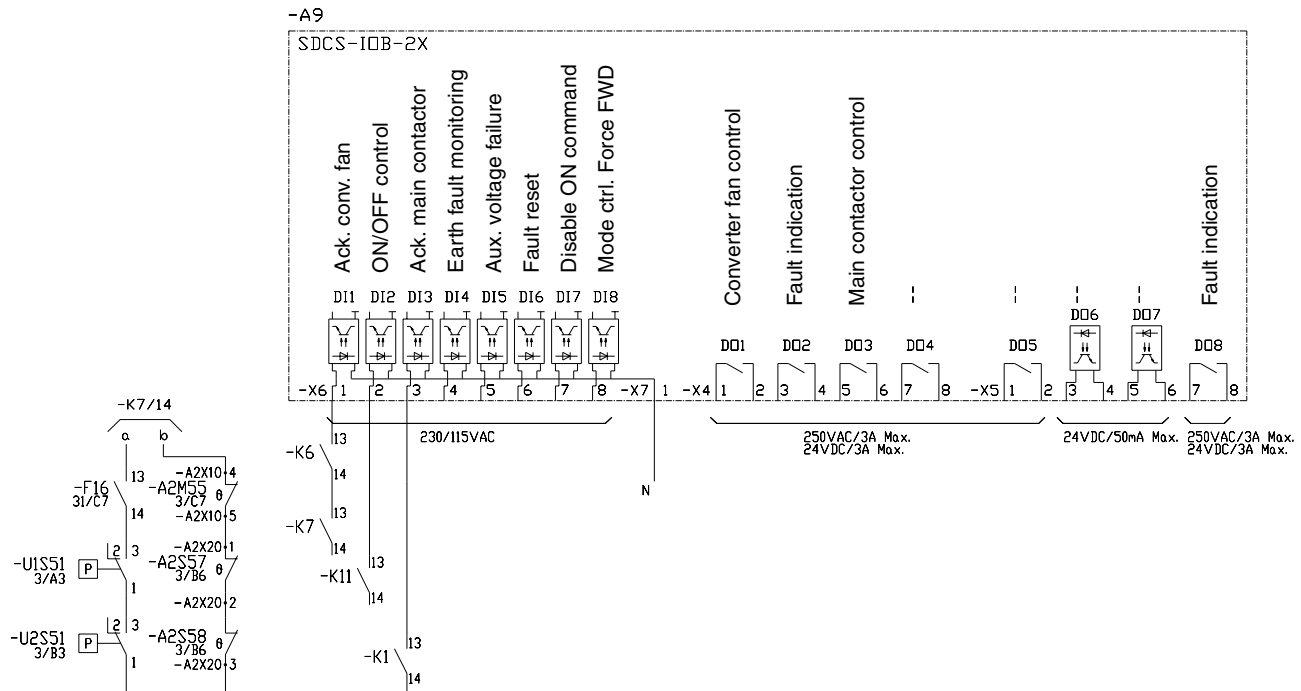
Input/Output	Assignment/Information
DI1	<i>Fan acknowledge, fan temperature protection, fan circuit breaker, pressure switch, DC reactor fan and DC reactor temperature protection</i> This input is used for monitoring the above equipment. (Starting the supply unit is only possible when this input is 1.) 0 = Fan not rotating, main contactor open, etc. 1 = Fan rotating, main contactor closed, etc.
DI2	<i>ON/OFF Control</i> 0 = Stop 0 → 1 = Run
DI3	<i>Main Contactor Acknowledge</i> Feedback from main contactor
DI6	<i>Reset</i> 0 → 1 = Reset
DO1	<i>Fan Control</i>
DO2	<i>Fault</i> 0 = Fault present 1 = No fault present
DO3	<i>Main Contactor Control</i> 0 = Open main contactor 1 = Close main contactor





**Description** The ON signal on DI2 is generated by switch S11, whose START position activates K11. The hold circuit is activated by DO3, which is energised after the start signal on DI2. A50 (reset) is activated by the EMS (Emergency Stop) circuitry, of which contactors K26 and K27 are part.

Digital output DO3 holds K11 and the main contactor is closed. DO1 activates the cooling fans through K6 and K7 (which also control the supply unit fan contactor not presented in this diagram).



**Description** DI1 feedback passes through auxiliary contacts of K6 and K7. This loop also includes all thermal switches (bridge and DC reactor fans, DC reactor windings), DC reactor circuit breaker, and the bridge pressure relay (B4 and B5 only).

The ON/OFF signal on DI2 is controlled by an auxiliary contact of K11.

DI3 feedback is controlled by an auxiliary contact of K1.

The reset signal on DI6 is normally received from a reset circuit in the Emergency Stop circuitry.



## IGBT Supply Unit Wiring

### Charging Circuit

The wire used for connecting the charging components must have a sufficient cross-sectional area. The minimum value for each IGBT supply module type is given in the table below.



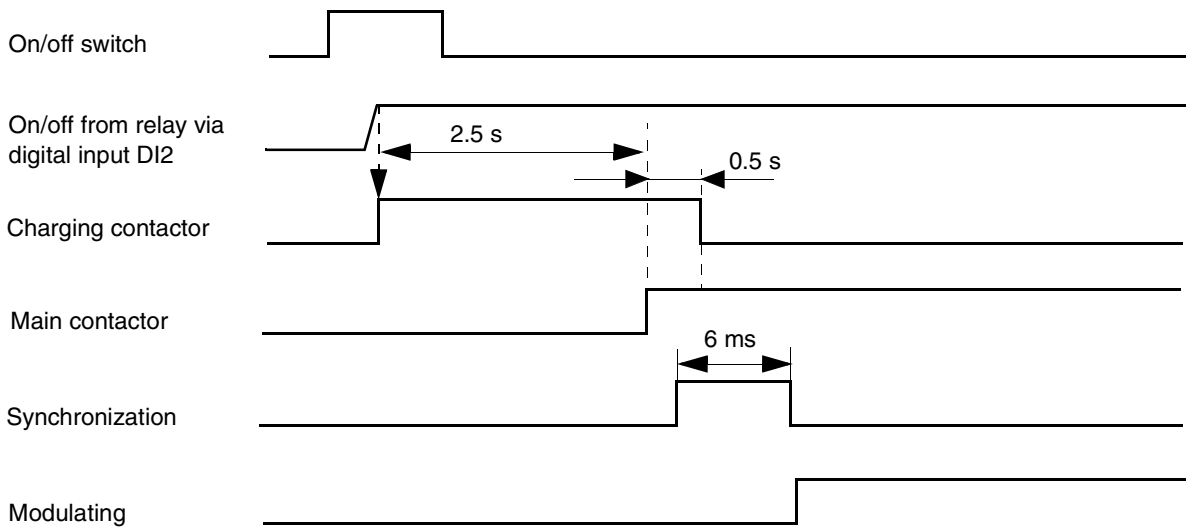
**WARNING!** Use only double-insulated wire for making the connections of the charging circuit.

Supply Module Type – ACN 634...			Min. Area (mm <sup>2</sup> )
0060 3 ... 1125 3	0070 5 ... 0495 5	0060 6 ... 0485 6	6
1445 3 ... 2145 3	0615 5 ... 1765 5	0605 6 ... 1385 6	10
2820-3	2165 5, 2625 5	1715 6	16
	3450 5	2125 6, 2545 6	25
		3350 6	35
		5140 6	50

### Control Wiring

The assignments of the digital inputs and outputs of the NDCU Control Unit and a description of the start sequence are shown below.

Input/Output	Assignment/Information
DI1	<i>Fan Acknowledge and Temperature Supervision</i> 1 = Run
DI2	<i>ON/OFF Control</i> 0 = Off 1 = On
DI3	<i>Main Contactor Acknowledgement</i> 1 = Closed
DI4	<i>External Fault (optional)</i> 1 = Fault
DI6	<i>Reset</i> 0 → 1 = Reset
DO1	<i>Charging Contactor Control</i> 0 = Open charging contactor 1 = Close charging contactor
DO2	<i>Fault</i> 0 = Fault present 1 = No fault present
DO3	<i>Main Contactor Control</i> 0 = Open main contactor 1 = Close main contactor

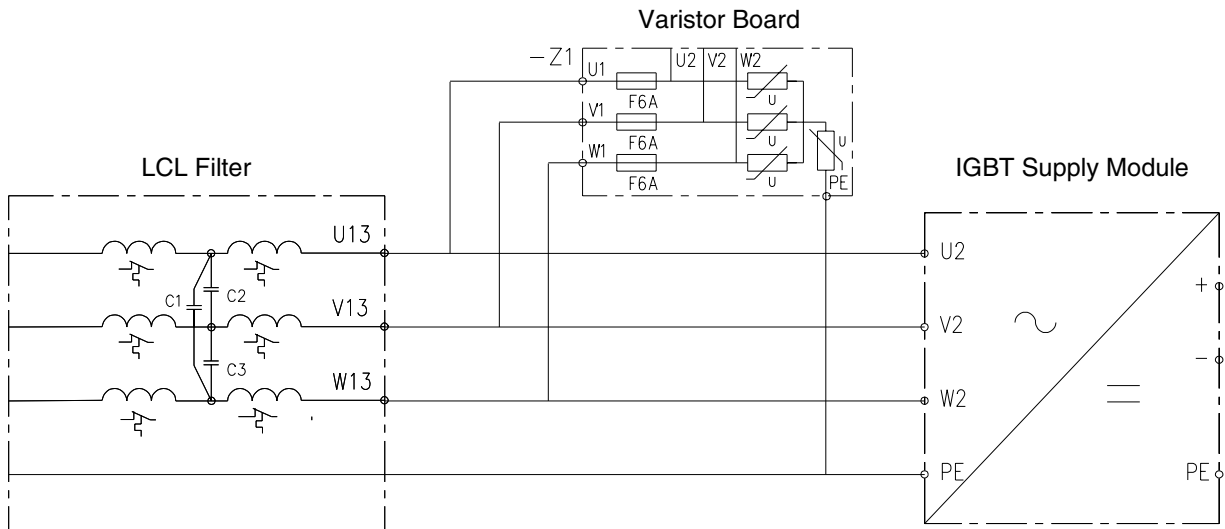


Step	Operation
1	ISU control receives the ON command (DI2 rising edge) from the starting switch.
2	ISU control logic closes the charging contactor control circuit (DO1)
3	ISU control logic closes the main contactor and cooling fan control circuit (DO3).
4	ISU control logic receives the “main contactor on” acknowledgement (DI3).
5	ISU control logic receives the “cooling air fan in operation” acknowledgement (DI1).
6	ISU synchronizes itself to the supply network in case DC voltage is OK (charging is completed successfully).
7	ISU control starts modulation. The inverter units can be started.

**Connecting the NDCU Control Unit** The connection of the NDCU to an IGBT supply module is the same as for an inverter module. See page 3-16.

**R10i...R12i Internal Wiring** Parallel-connected Frame R10i to R12i IGBT supply modules have the same internal connections as inverter modules. See page 3-18.

**Varistor Board** The varistor board (if required) is to be connected between the LCL filter and the supply module as follows:



### Drive Unit Wiring

#### Charging Circuit

The wires used for connecting the charging components must have a sufficient cross-sectional area. The minimum values for each inverter module type is given in the table below. See also the circuit diagrams in Appendix A.



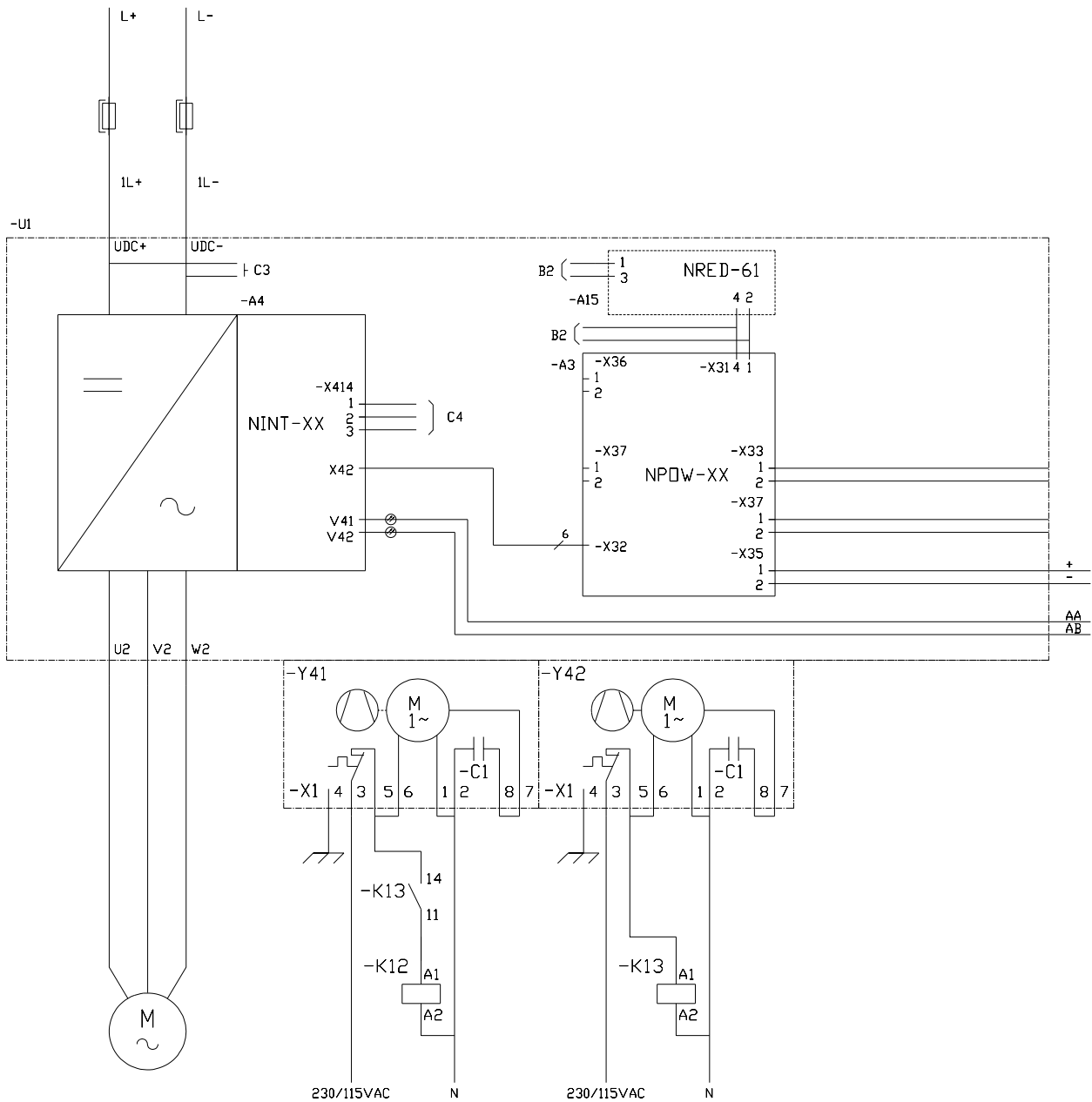
**WARNING!** Use only double-insulated wire types for making the connections of the charging circuit.

Inverter Module Frame	Min. Area (mm <sup>2</sup> )	Where to Use
R5i, R6i	0.75	Charging control
	2.5	Contactors to resistor Between resistors (690 V types only)
R7i to R11i	0.75	Charging control
	1.5	NCHM to ground Fuse to resistor(s)
	2.5	DC bus to fuse Resistor(s) to DC bus
R12i	0.75	Charging control
	1.5	NCHM to ground
	2.5	DC bus to fuse Fuse to resistor(s) Resistor(s) to DC bus

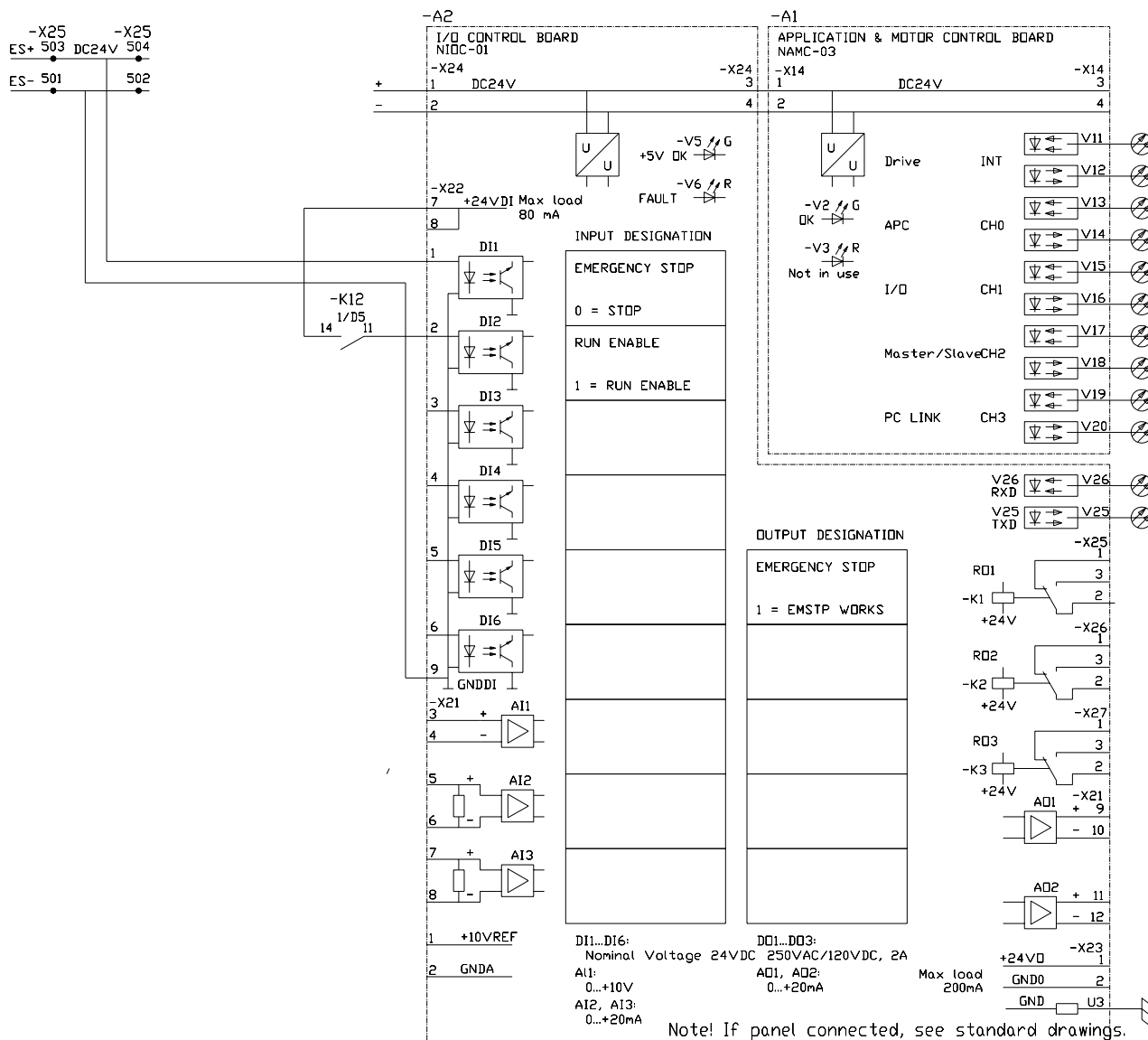
**Control Wiring** The assignments of the digital inputs and outputs of the NDCU Drive Control Unit are shown below.

The example is for the System Application Program, but adaptable for other application programs. For further information, see the *Firmware Manual* of the appropriate application program.

Input/Output	Assignment/Information
DI1	<i>Emergency Stop</i> This input is used for the Emergency Stop function. 0 = Emergency Stop 1 = Continue normal operation
DI2	<i>Run Enable, External Cooling Fan Temperature Supervision</i> The input is normally used for the Run Enable signal. If this input is 0, an attempt to start the drive produces a fault. (Application program-controllable.) 0 = Run Enable signal not present 1 = Run Enabled
DI3*	<i>Start/Stop</i> 0 = Stop 0 → 1 = Start
DI4*	<i>Reverse</i>
DI5*	<i>Reset</i> 0 → 1 = Reset
*Digital inputs DI3...DI5 are assigned these functions in HAND/AUTO Mode when no communication module (e.g. fieldbus adapter) is active. The digital inputs are application program-controllable.	



**Description** The Run Enable signal on DI2 is normally used for cooling fan feedback. Contactors K12 and K13 are used for monitoring the thermal switches in fans Y41 and Y42. The contacts of K12 are connected to DI2; thus the tripping of either fan cancels the Run Enable signal.



**Description** The Emergency Stop control is fed to digital input DI1 (typically from the supply unit). The Run Enable signal is applied via a contact of K12 to digital input DI2. DI2 can however be overridden or assigned to another purpose (e.g. with Frames R2i...R5i, switch fuse feedback) from the application program.

Relay output RO1 is often used for Emergency Stop acknowledgement to the EMS circuitry.

**Connecting the Control Unit**

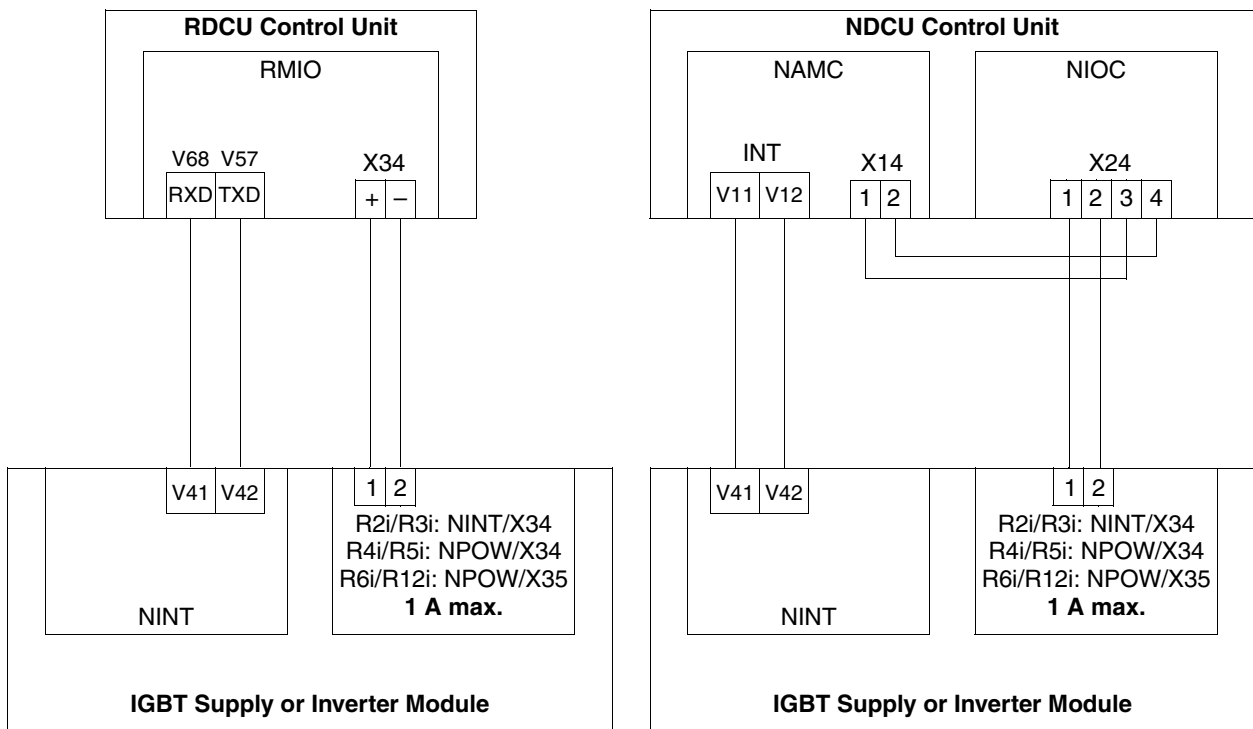
The control unit controls the power module (i.e. IGBT supply module or inverter module) through a fibre optic link between the unit and the NINT board inside the power module.

On an RDCU control unit, the power module is connected to fibre optic connectors V57 and V68.

On an NDCU control unit, the power module is connected to the INT channel.

The control unit can be powered from the inverter/IGBT supply module, provided that the maximum current of 1 A is not exceeded. The control unit can also be powered from an external 24 V DC supply. Note also that the current consumption of the RDCU unit is dependent on the modules attached (see Appendix C).

The diagram below shows the connections between the control unit and the power module.



Fibre Optic Link

Recommended max. distance:  
 Plastic (POF) cable: 20 m  
 Hard-Clad Silica (HCS®) cable: 50 m

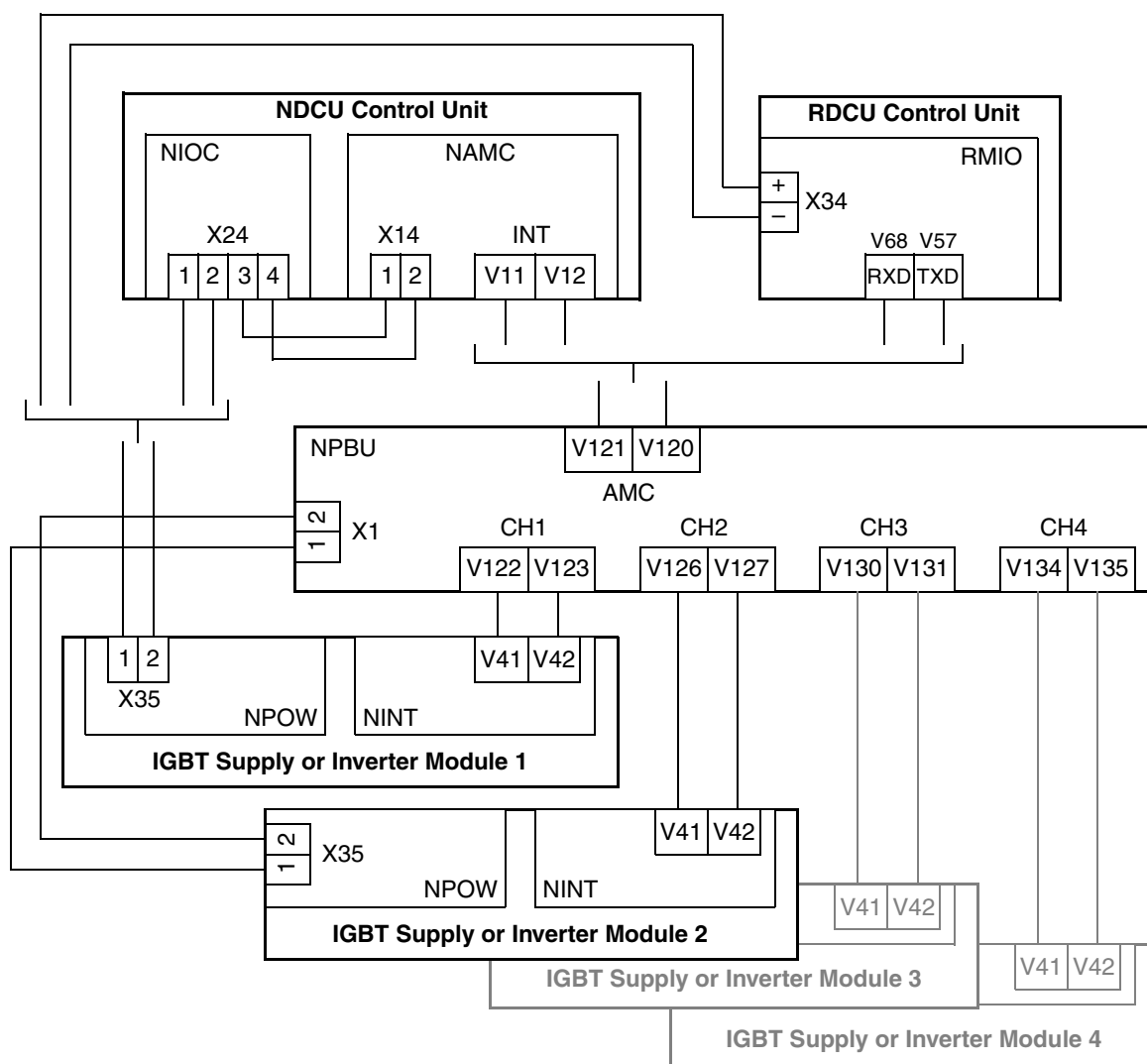
Figure 3-2 Connecting the control unit and the power module.



**Parallel-connected Modules**

Frame 2xR11i to 4xR12i units consist of parallel-connected modules as shown below; one RDCU or NDCU unit controls all the modules through an NPBU optical branching unit.

The control unit can be powered from the inverter/IGBT supply module, provided that the maximum current of 1 A is not exceeded. (Power the NPBU branching unit from a different supply/inverter module to distribute the load.) The control unit and branching unit can also be powered from an external 24 V DC supply. Note also that the current consumption of the RDCU unit is dependent on the modules attached (see Appendix C).



*Figure 3-3 Connection of parallel power modules to an RDCU or NDCU control unit through an NPBU optical branching unit.*

**R10i...R12i Internal Wiring** Frame R10i, R11i, R12i modules consist of individual phase modules, and are internally wired as shown below.

The cables depicted are included in the module kit.

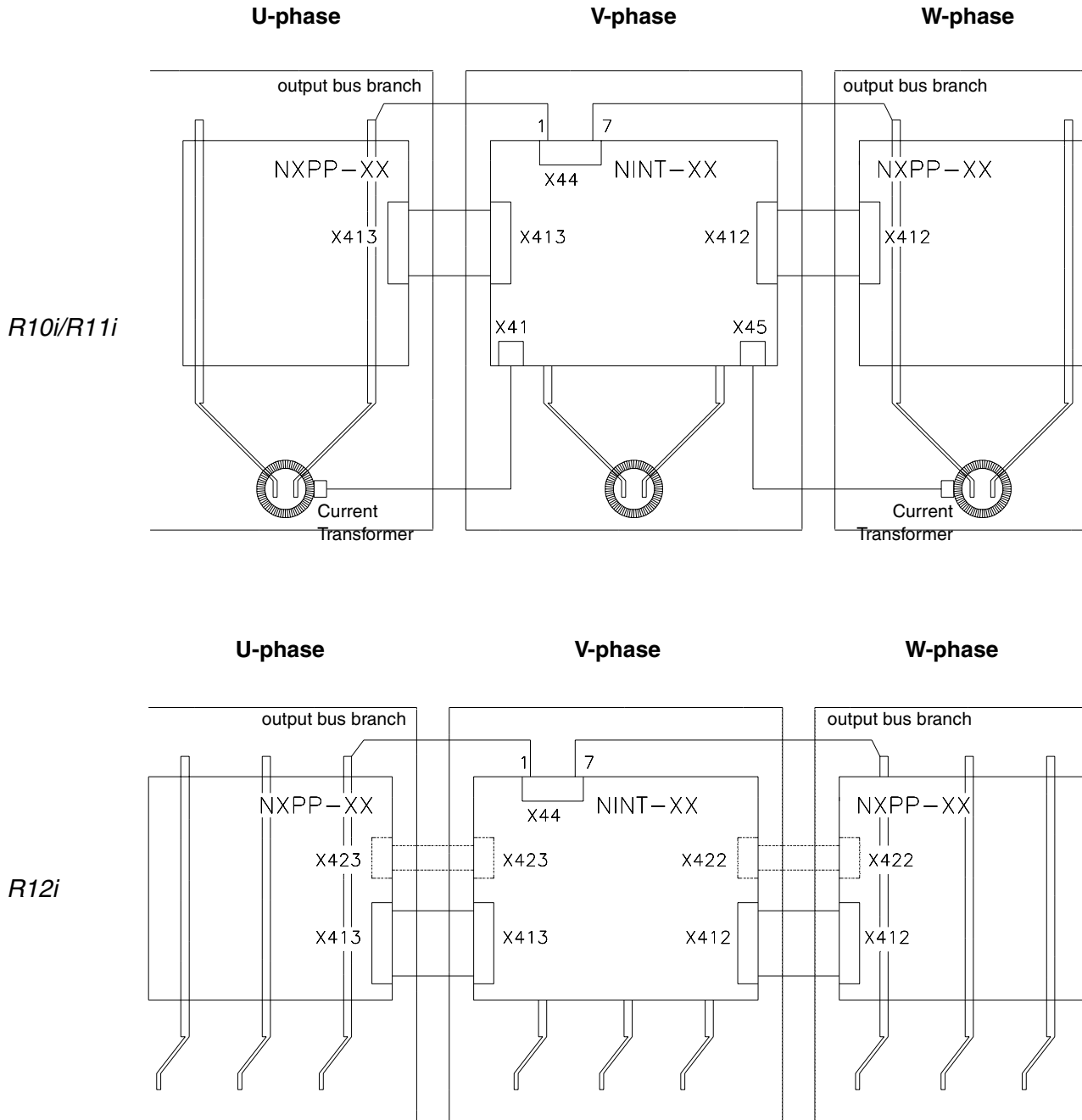


Figure 3-4 Internal wiring of R10i...R12i inverter/IGBT supply modules.

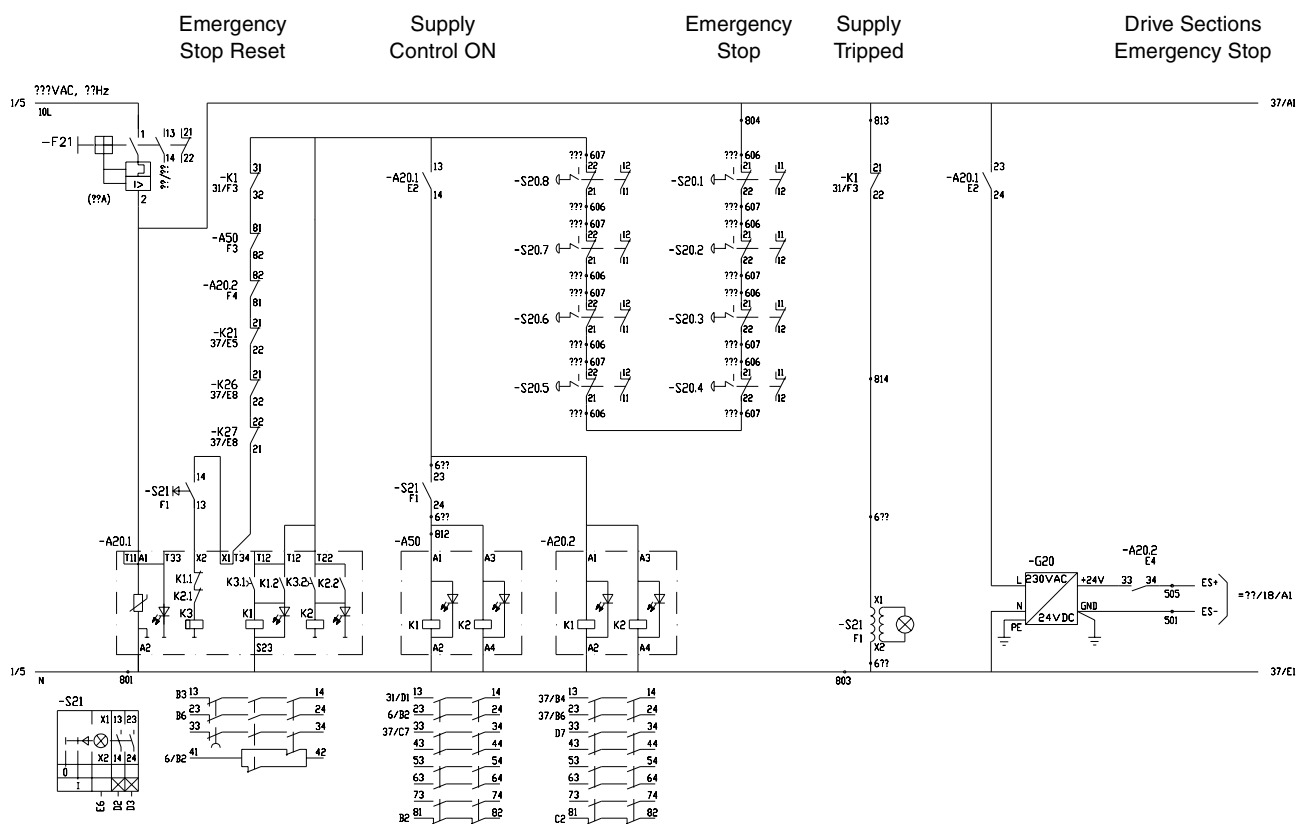
### The Emergency Stop Circuit

The Emergency Stop (EMS) circuit is typically controlled by the supply unit. The circuit controls the drives through a 24 V DC bus.

There are several different Emergency Stop modes in the drive application program:

- Stop by Ramp (adjustable deceleration time)
- Stop by Torque (at torque limit)
- Coast to Stop (torque decreased to zero)
- Follower Stop (for Master/Follower application).

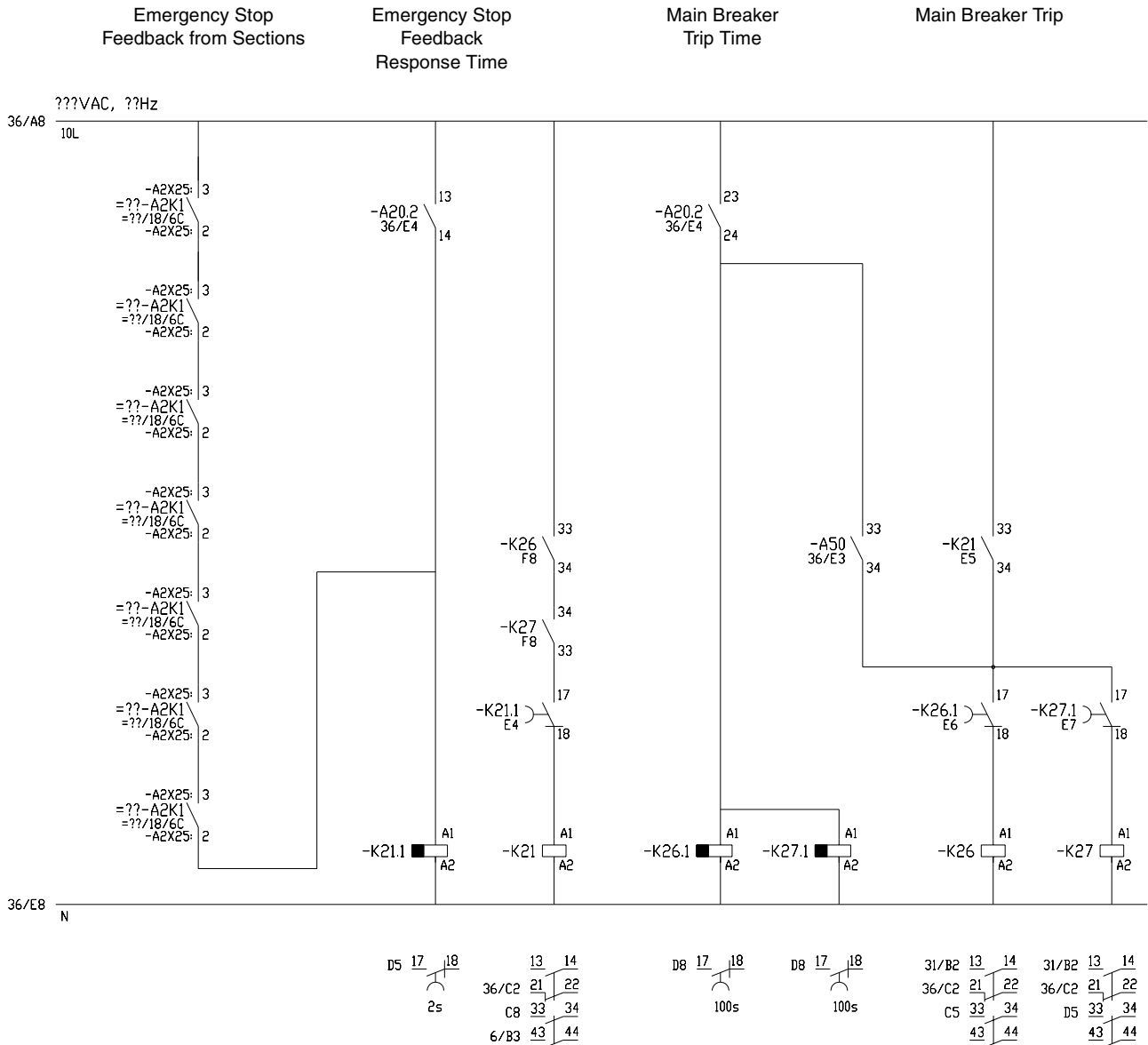
The EMS circuit is acknowledged by each drive unit (relay output RO1). The maximum acknowledgement time and the main contactor trip delay are adjustable. If no acknowledgement is received within the time set, the supply unit is tripped.



#### Description

When the supply is started, the push-button S21 has to be used. This resets the EMS circuit and energises relay A20.2, thus making a connection for the EMS signal to the drives. Relays A20.1, A20.2 and A50 enable the supply control relays and the 24 V signal supply.

When Emergency Stop is activated, A20.2 is de-energised, and its contacts on the 24 V signal open, tripping the supply main contactor after an adjustable delay, and cutting the 24 V signal to the drives. This is interpreted as an Emergency Stop command. The tripping of the supply main contactor is indicated by a pilot light.



**Description**

The supply unit main contactor is tripped after a certain delay. The delay is needed since drives are stopped by ramp and feed energy to the supply network.

The Emergency Stop acknowledgement from the drives is monitored by K21.1. If no acknowledgement is received within a certain time (typically 2 seconds), the supply is tripped. If acknowledgement is received in time, the supply is tripped after an adjustable delay (max. 100 seconds) by means of K26 and K27.

**Prevention of Unexpected Start**

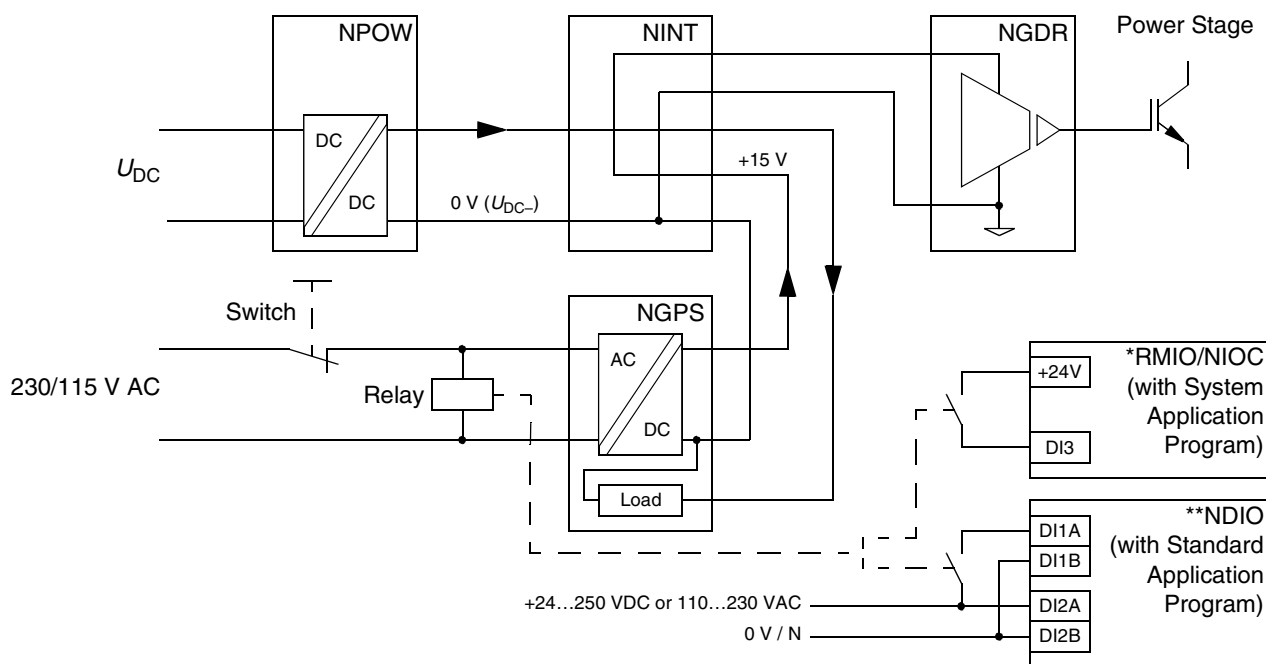
This function makes it possible to prevent an inadvertent starting of the drive so that maintenance work on the machinery can be carried out.



**WARNING!** The Prevention of Unexpected Start function does not disconnect the voltage from the main and auxiliary circuits. Therefore, maintenance work on electrical parts can only be carried out after switching off the main supply of the drive system.

Inverter modules equipped with the Prevention of Unexpected Start option have an additional board (NGPS) fitted. This board provides the control voltage for the output stage of the inverter module. The NGPS board in turn is powered from the 230/115 V AC auxiliary power circuit via a normally-closed switch installed by the customer in a suitable location (for example, a control desk). By opening this switch, the operator can block the control voltage to the inverter power stage, so the voltage needed to rotate the motor cannot be generated.

In addition to the switch, a relay is to be connected in parallel with the power input of the NGPS board. A normally-open contact of this relay is wired to a digital input of the inverter unit. (This is to prevent erroneous control of the power stage and possible damage in case the switch is opened while the inverter is running.) See the wiring diagram below.



\*DI3 is reserved for this function by default.  
 \*\*Additional RDIO/NDIO or fieldbus adapter module required.

Figure 3-5 Wiring of the Prevention of Unexpected Start function.

**NDIO/NAIO/NTAC I/O Module Connection**

The diagram below shows the connection of an NAIO, NDIO or NTAC module to the drive unit. Multiple modules are connected in a ring. (The remainder of the extension module connections are detailed in its accompanying manual.)

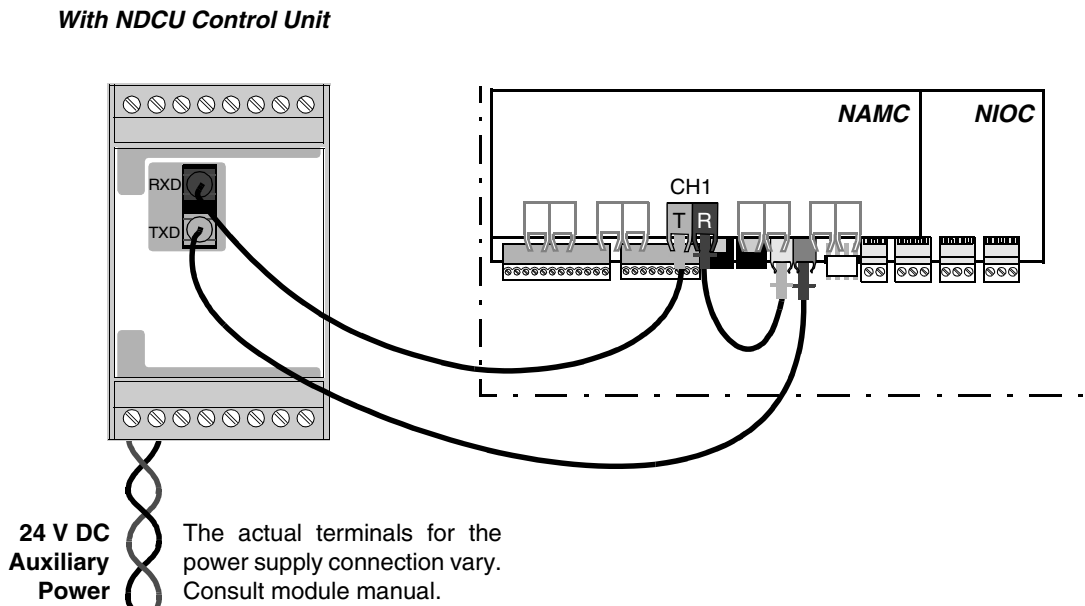
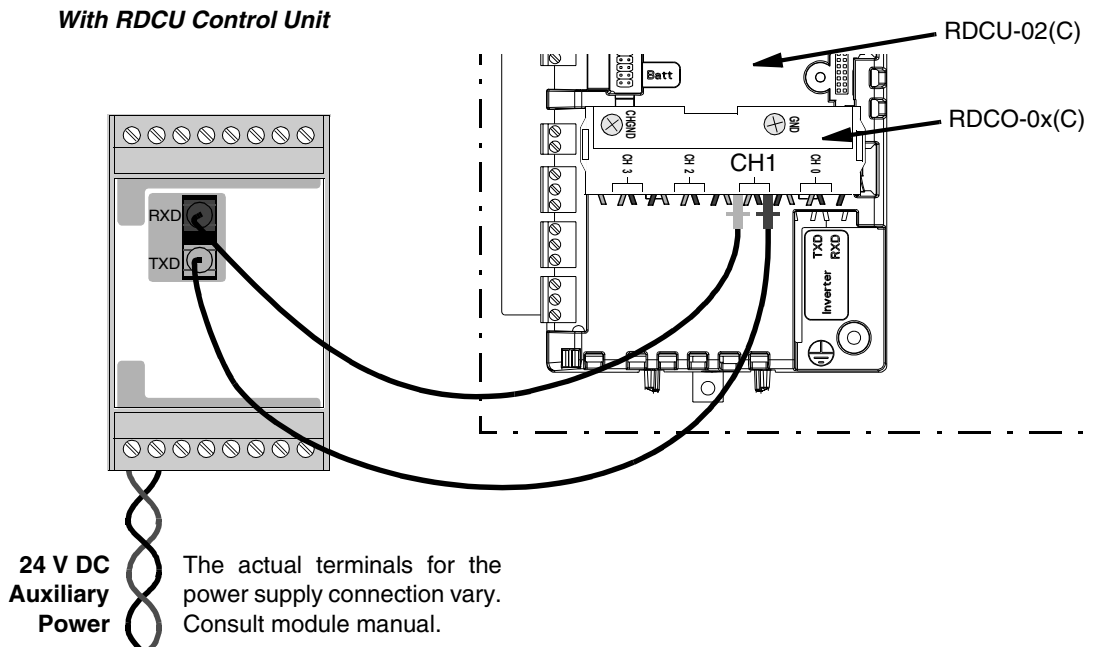


Figure 3-6 Connection of an NDIO/NAIO/NTAC module to the control unit.

**Fieldbus Adapter  
Module Connection  
(Type Nxxx Modules)**

The diagram below shows the connection of a type Nxxx fieldbus adapter module to the drive unit. (The remainder of the adapter module connections are detailed in its accompanying manual.)

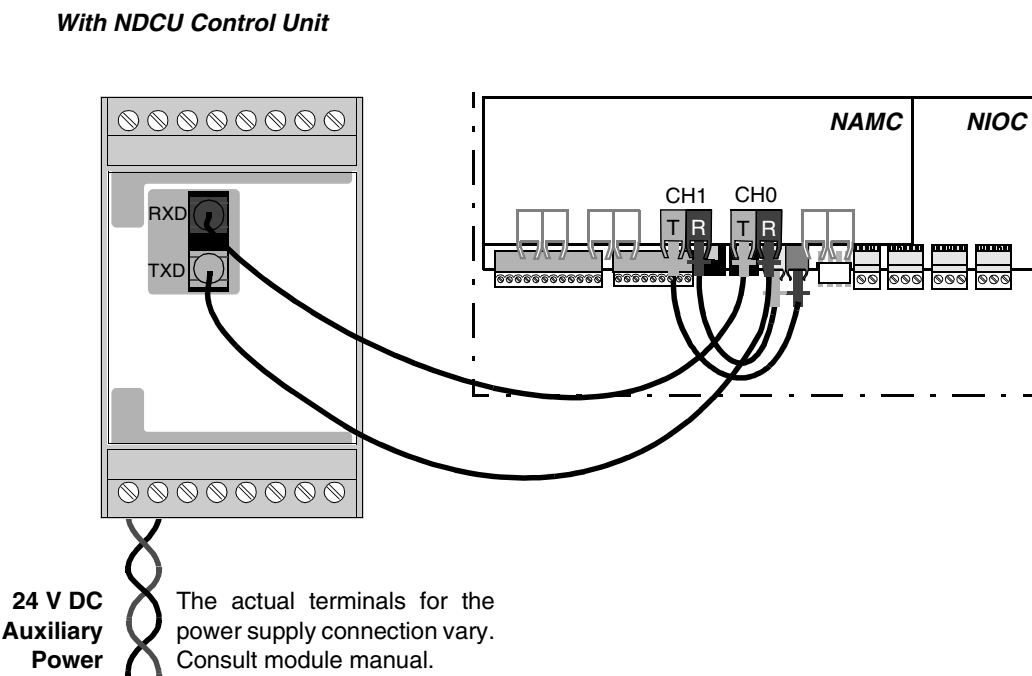
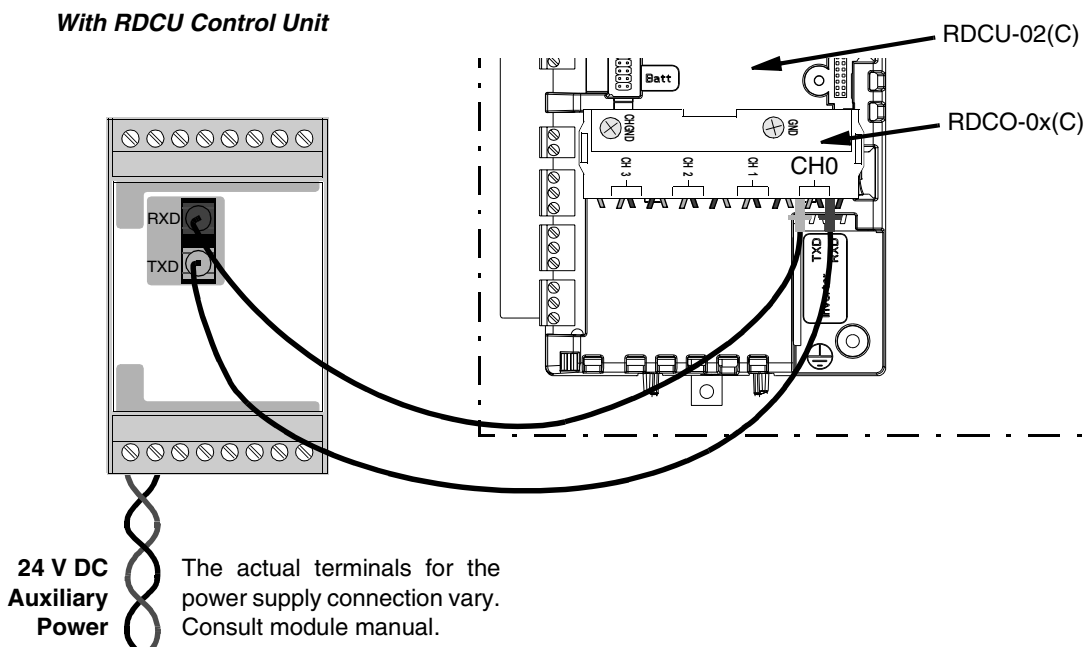


Figure 3-7 Connection of a type Nxxx fieldbus adapter module to the control unit.

**PC Connection**

The diagram below shows the connection of a PC to the control unit.

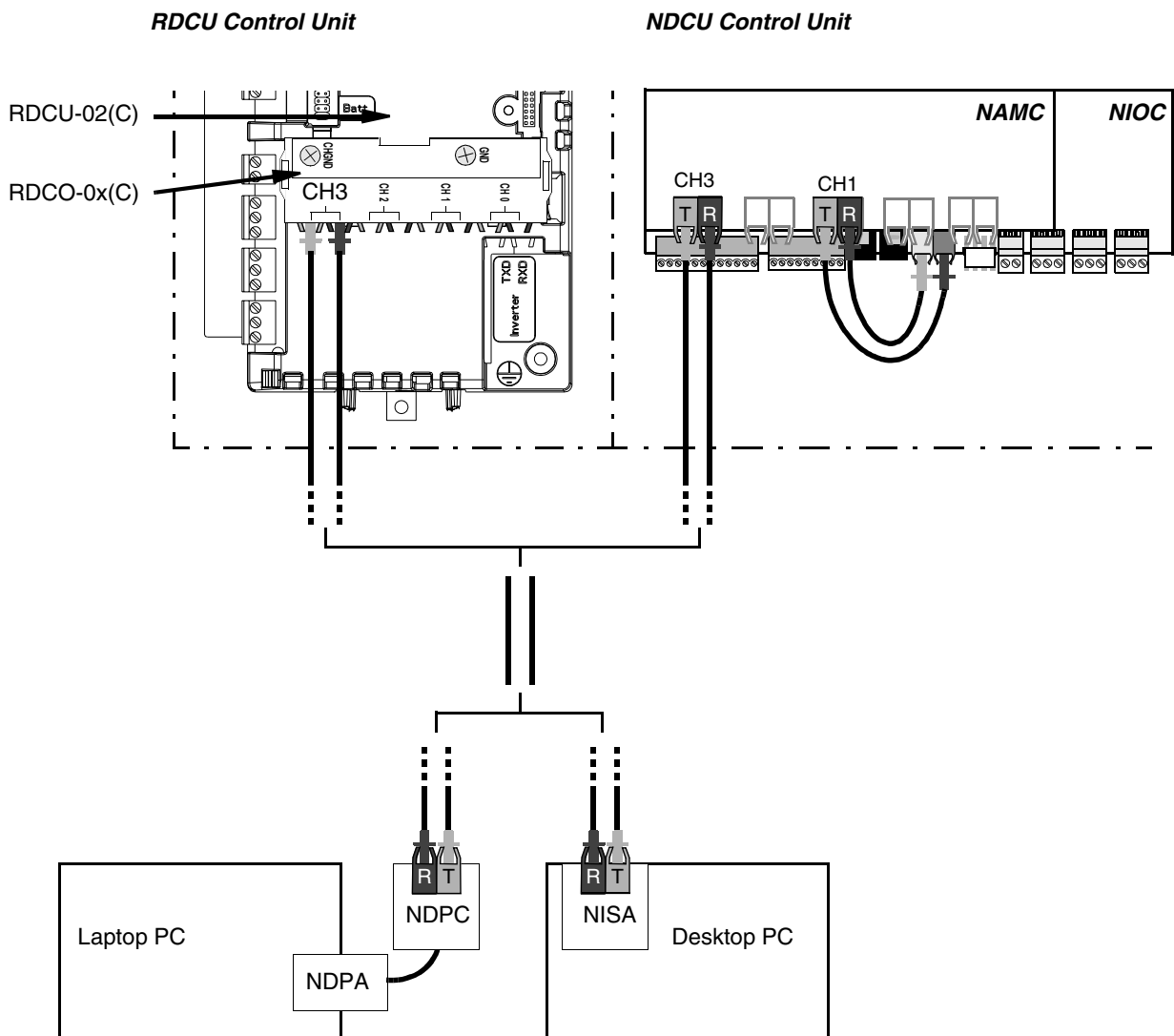


Figure 3-8 Connection of a PC to the control unit.



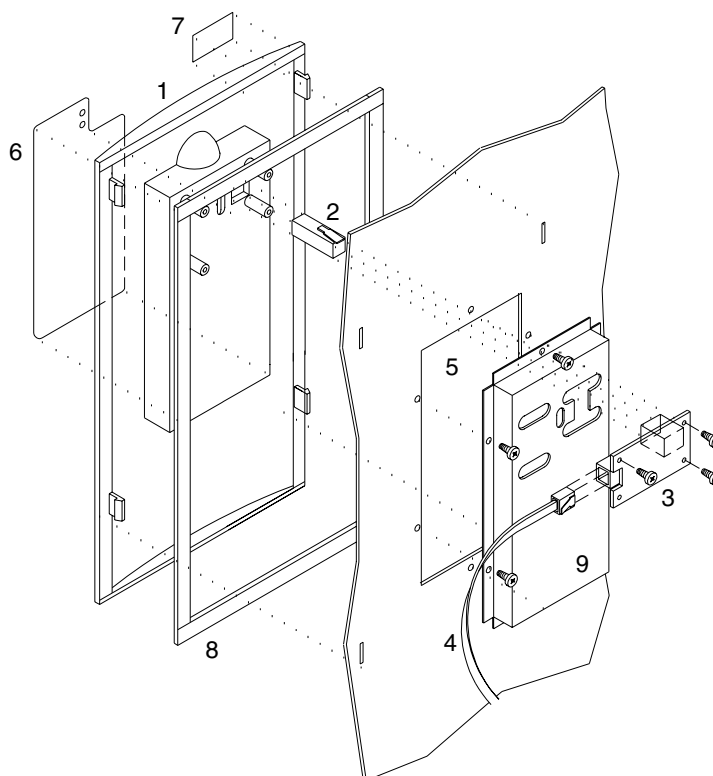
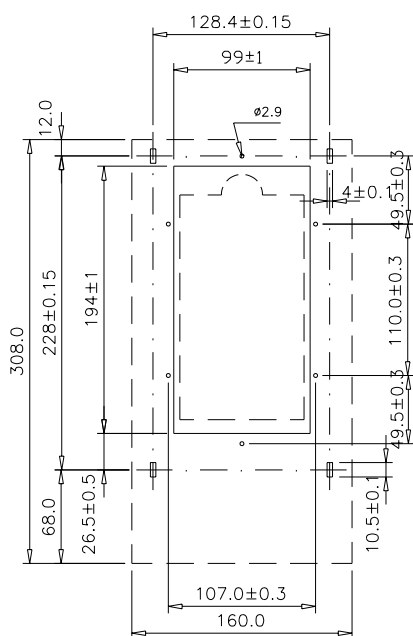
**Man/Machine Interface Installation**

The diagrams below show the mechanical installation and wiring of the CDP 312 Control Panel and the NLMD-01 LED Monitoring Display.

**Mechanical Installation**

The diagrams below show the required perforation for the Control Panel Mounting Platform and the NLMD LED Monitoring Display.

- 1 Control Panel Mounting Platform
- 2 Connector
- 3 NDPI-21
- 4 Cable to drive unit (NDCU)
- 5 Opening in the cabinet door
- 6 Sticker
- 7 ABB logo
- 8 IP 54 weatherstrips
- 9 EMC enclosure



Mounting Platform

Dimensions (H x W x D):  
308 x 160 x 33 mm  
Protrusion: 8 mm

Figure 3-9 Installation of the Control Panel Mounting Platform.

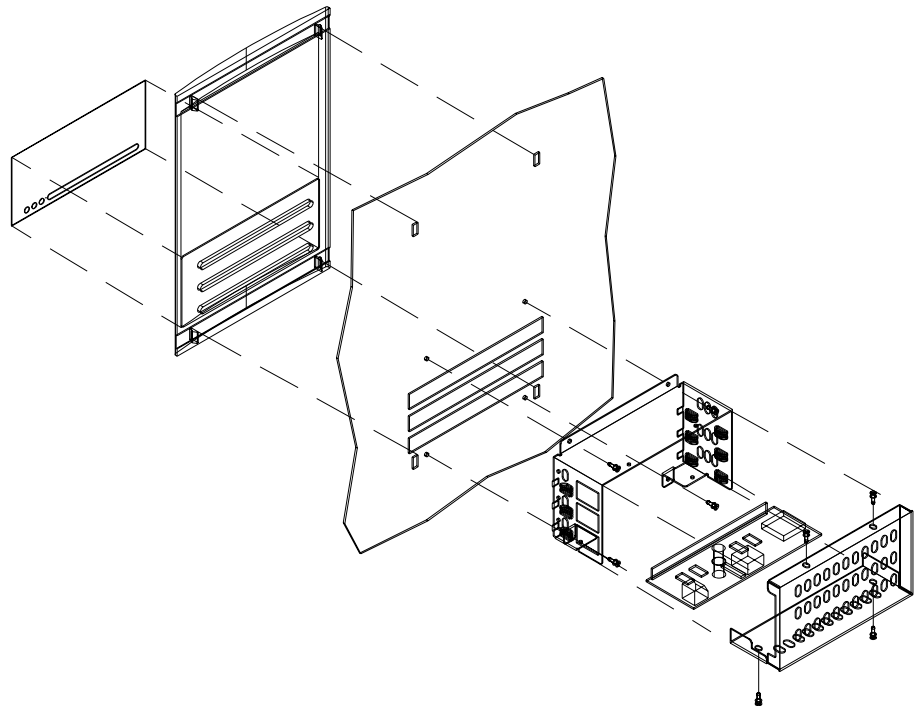
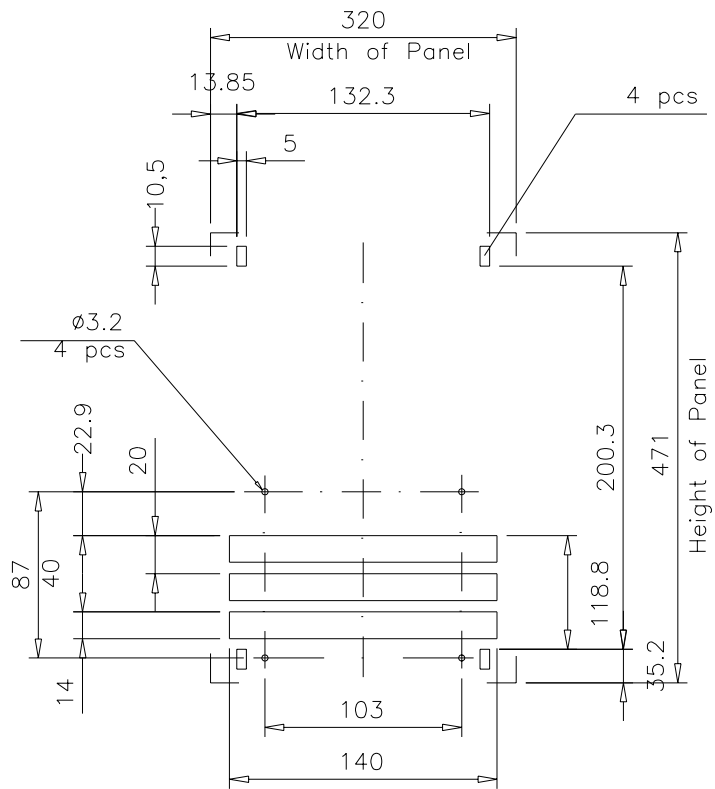
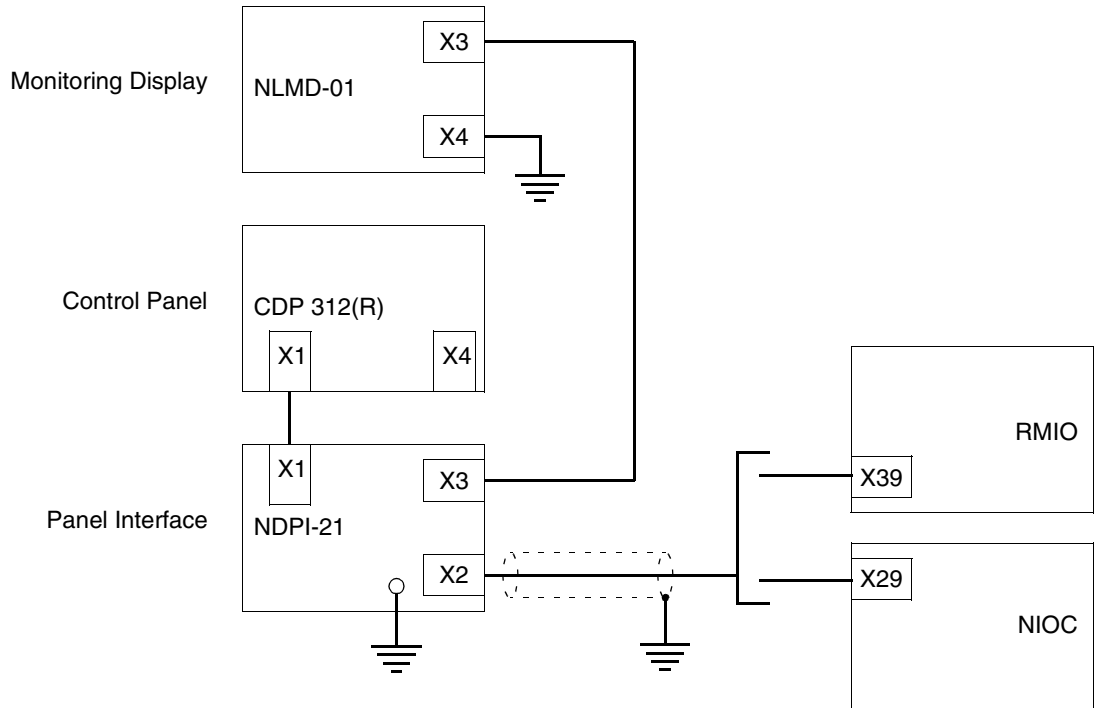


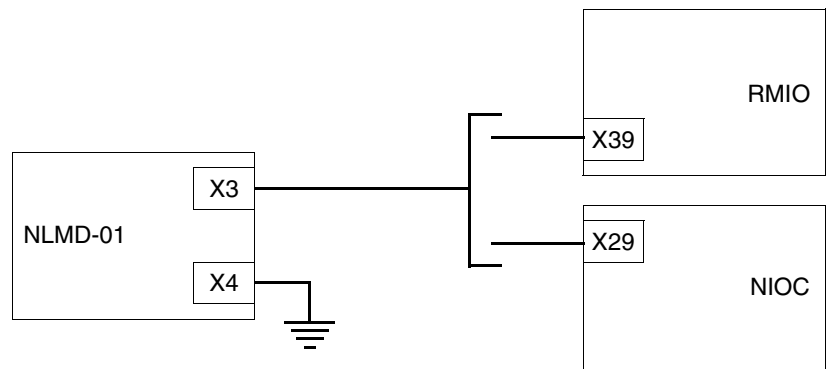
Figure 3-10 Installation of the NLMD-01 LED Monitoring Display.

**Wiring**

**Control Panel + Monitoring Display**



**Monitoring Display only**



**Earthing** The NLMD Monitoring Display and the NDPI board are earthed to the chassis as shown below.

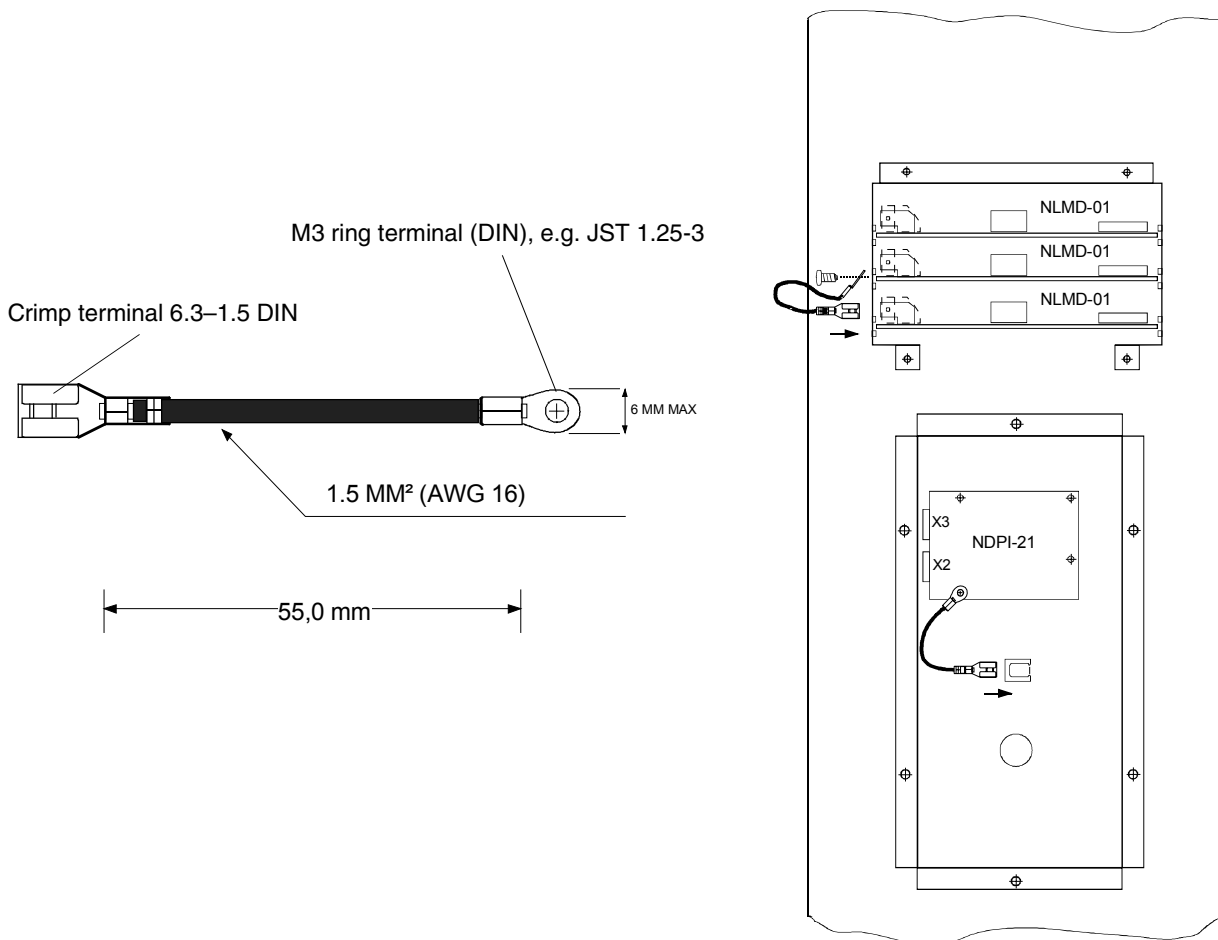


Figure 3-11 Earthing of the NLMD-01 LED Monitoring Display and the NDPI Connection Board.

## ***Appendix A – Circuit Diagrams***

---

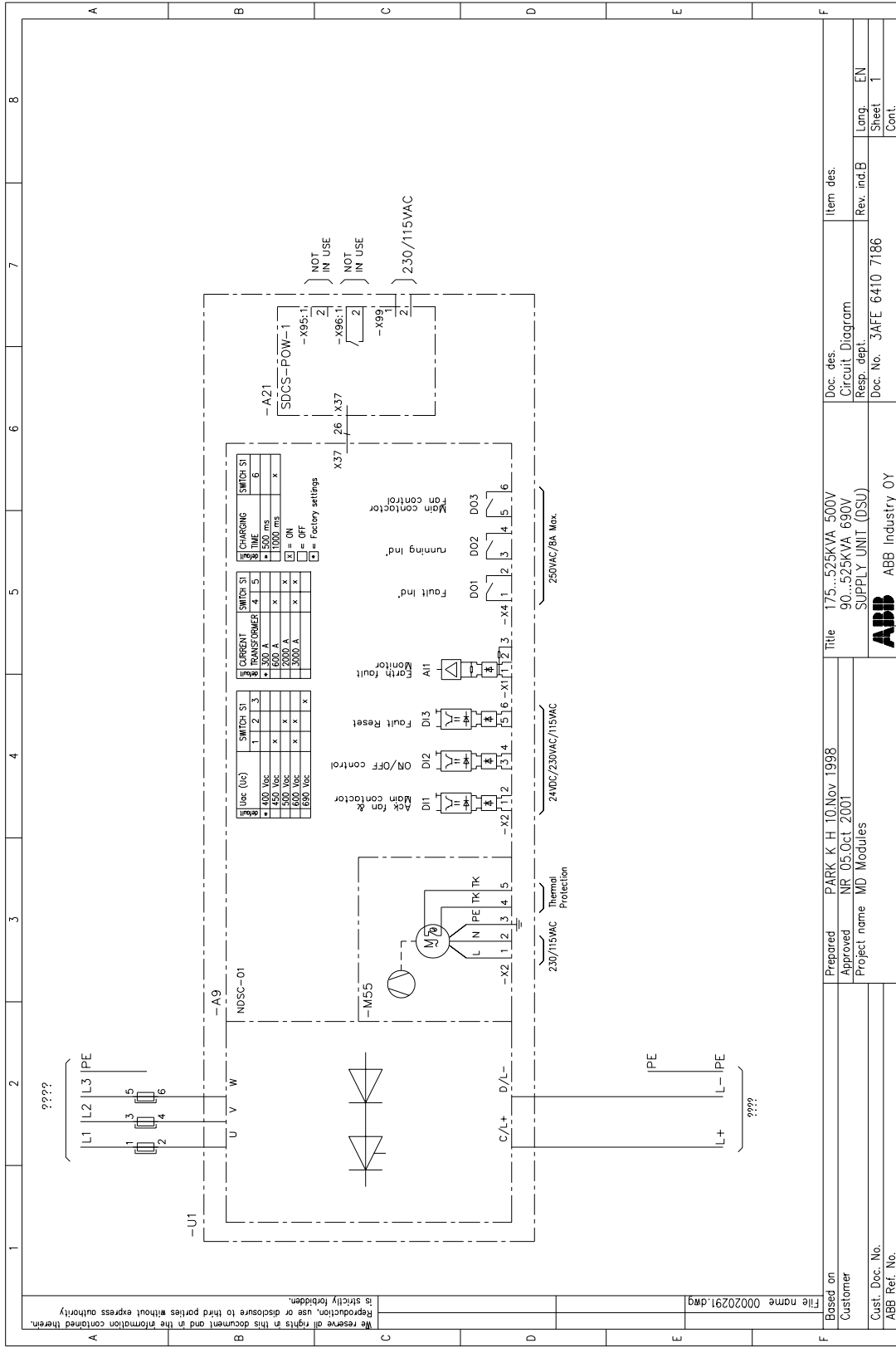
This Appendix contains basic circuit diagrams for ACS 600 MultiDrive Modules components.

---

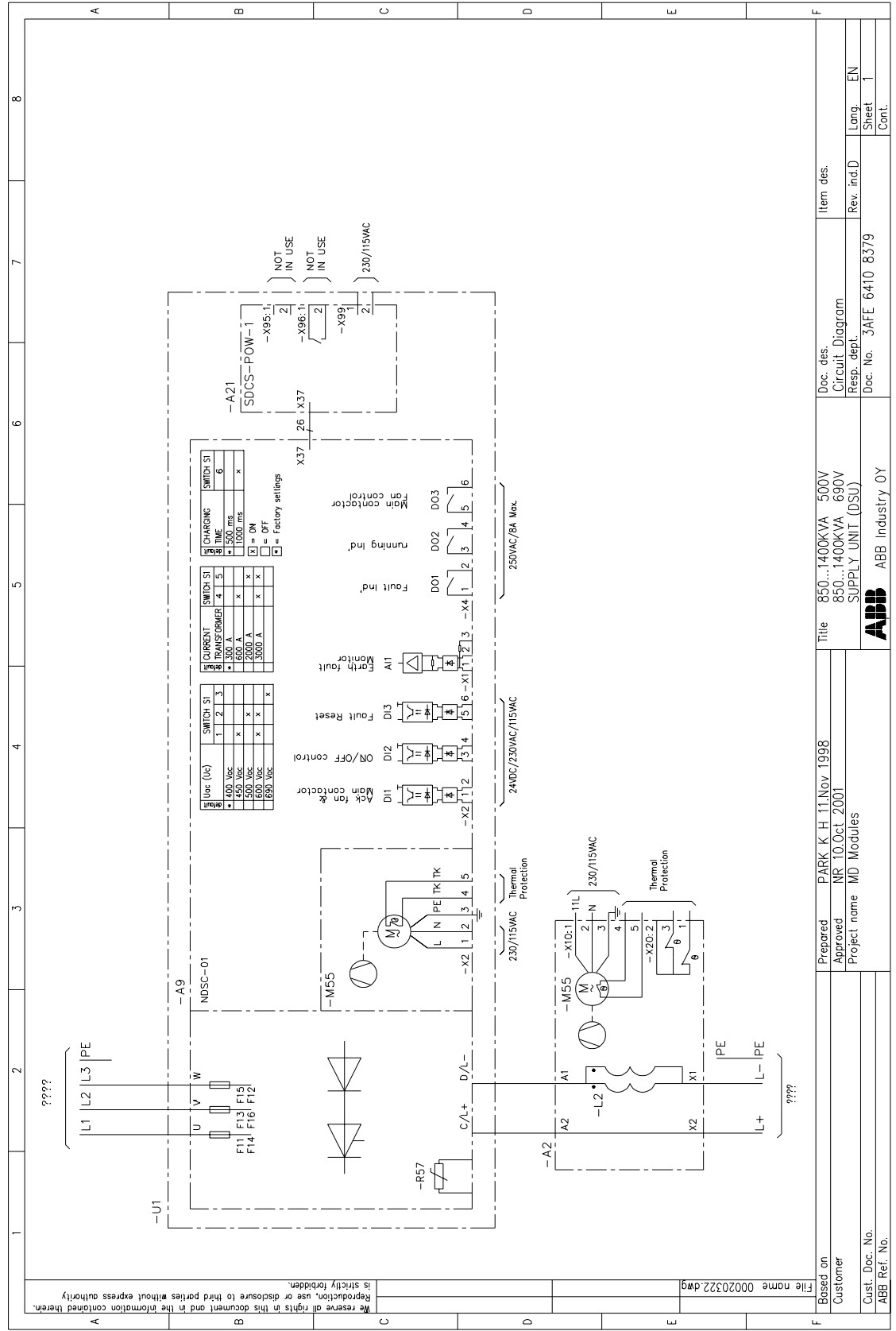
**Note:** A CD-ROM containing relevant circuit diagrams, dimensional drawings, component selection tables, manuals and other documentation is available. Contact your local ABB representative.

---

Diode Supply Units

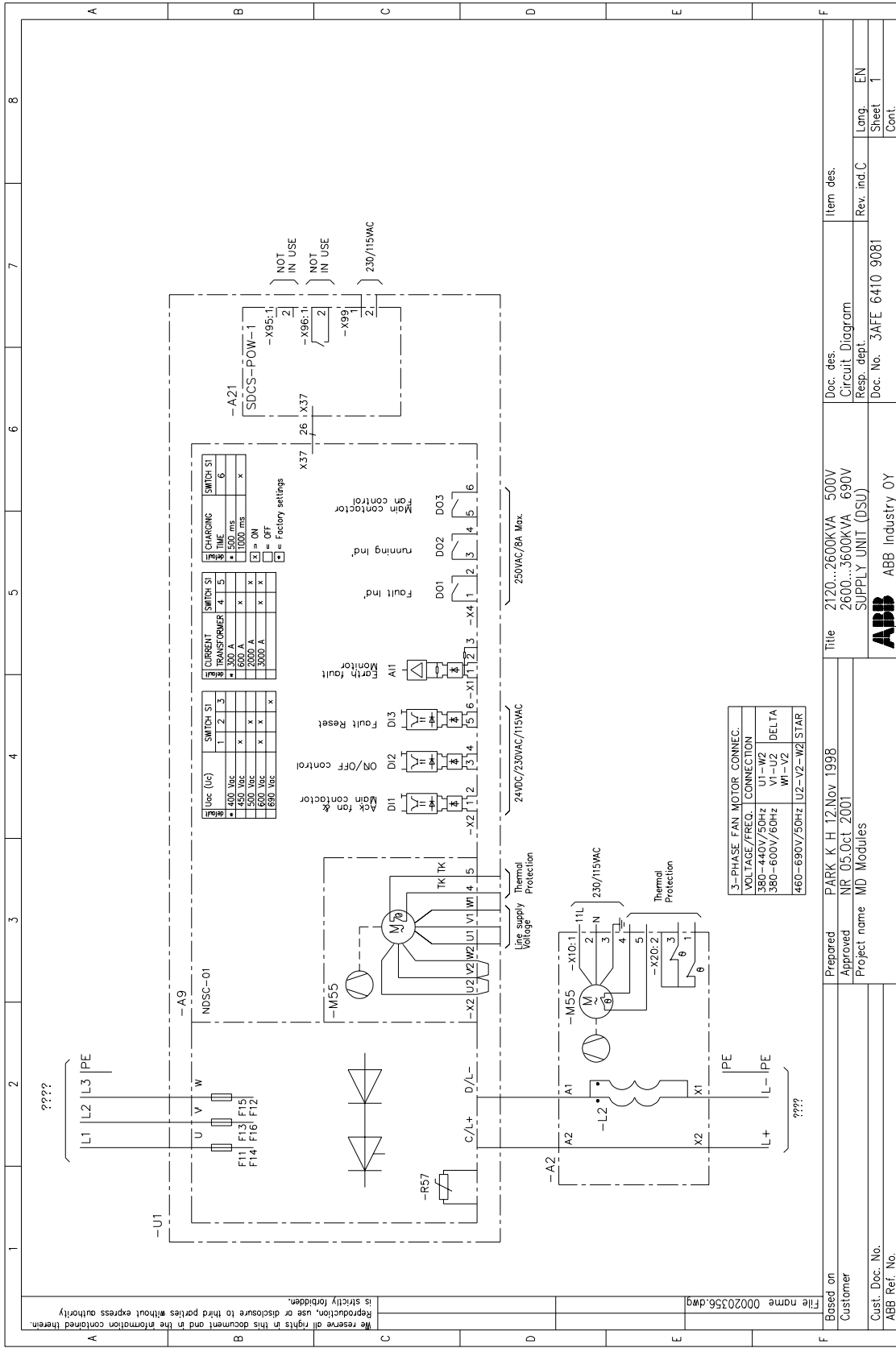


File name: 00020291.dwg	Prepared: PARK K H 10 Nov 1998	Title: 175...525KVA 500V	Doc. des.:
Customer:	Approved: NR 05 Oct 2001	90...525KVA 690V	Circuit Diagram
Cust. Doc. No.:	Project name: MD Modules	SUPPLY UNIT (DSU)	Resp. dept.:
ABB Ref. No.:		ABB ABB industry OY	Doc. No. 3AFE 6410 7186
			Rev. ind.B
			Long
			Sheet 1
			Cont.



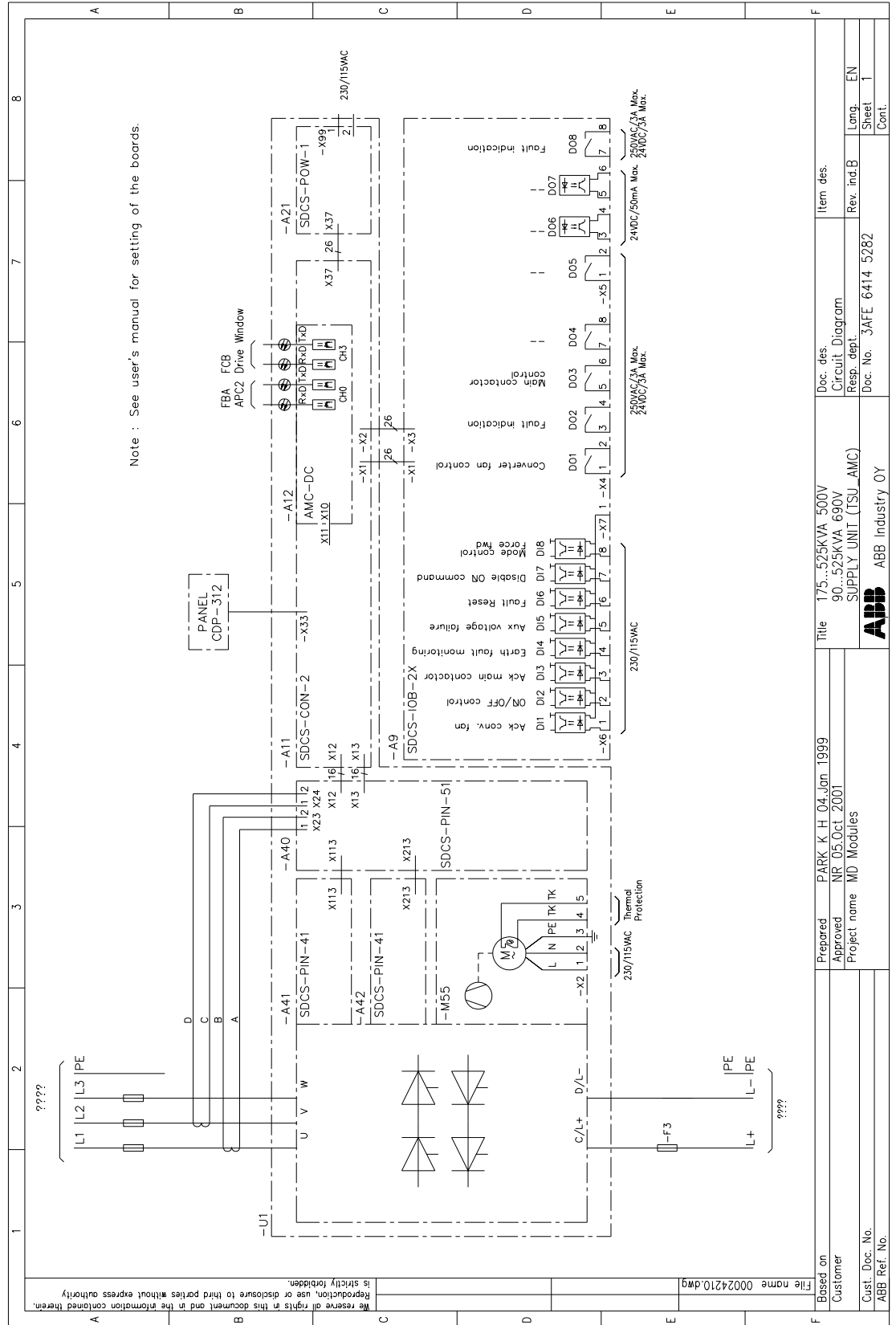
We reserve all rights in this document and in the information contained therein. Reproduction, use or disclosure to third parties without express authority is strictly forbidden.

Based on	PARK K H 11.Nov. 1998	Title	850...1400KVA 500V SUPPLY UNIT (DSU)	Doc. des.	Circuit Diagram	Item des.	
Customer	NR 10.Oct 2001	Prepared	MD Modules	Approved	Resp. dept.	Rev. ind.D	Long. EN
Cust. Doc. No.		Project name		Doc. No.	3AFE 6410 8379	Sheet	1
ABB Ref. No.						Cont.	



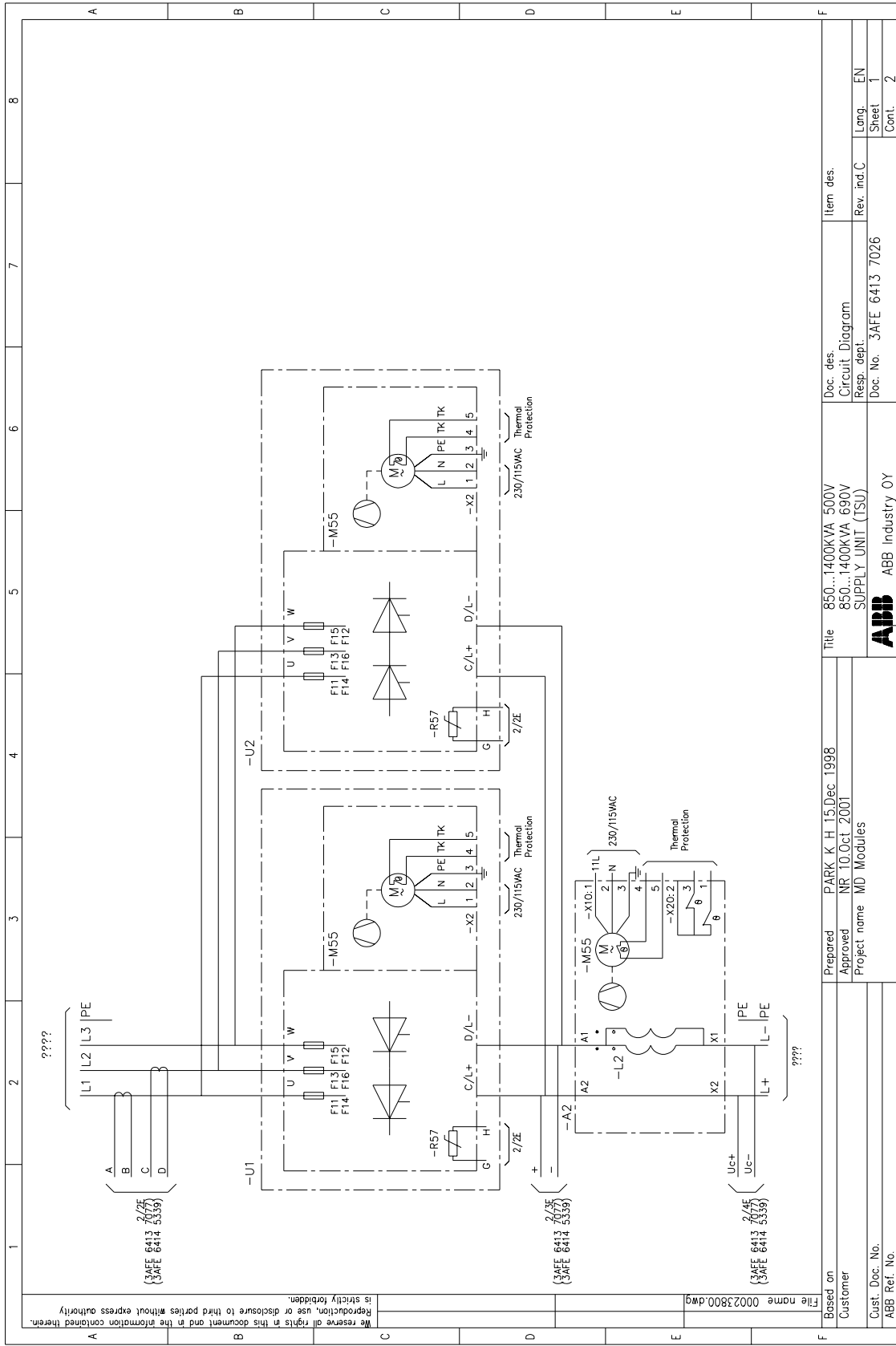


# Thyristor Supply Units



File name 00024210.dwg  
 Based on Customer  
 Customer  
 Project name MD Modules  
 Prepared PARK K H 04.Jan 1999  
 Approved NR 05.Oct 2001  
 Project name MD Modules

Doc. No.	3AFE 6414 5282	Doc. des.	Circuit Diagram	Item des.	
Rev.	EN	Resp. dept.		Rev. int.B	
Lang.	EN				
Sheet	1				
Cont.					

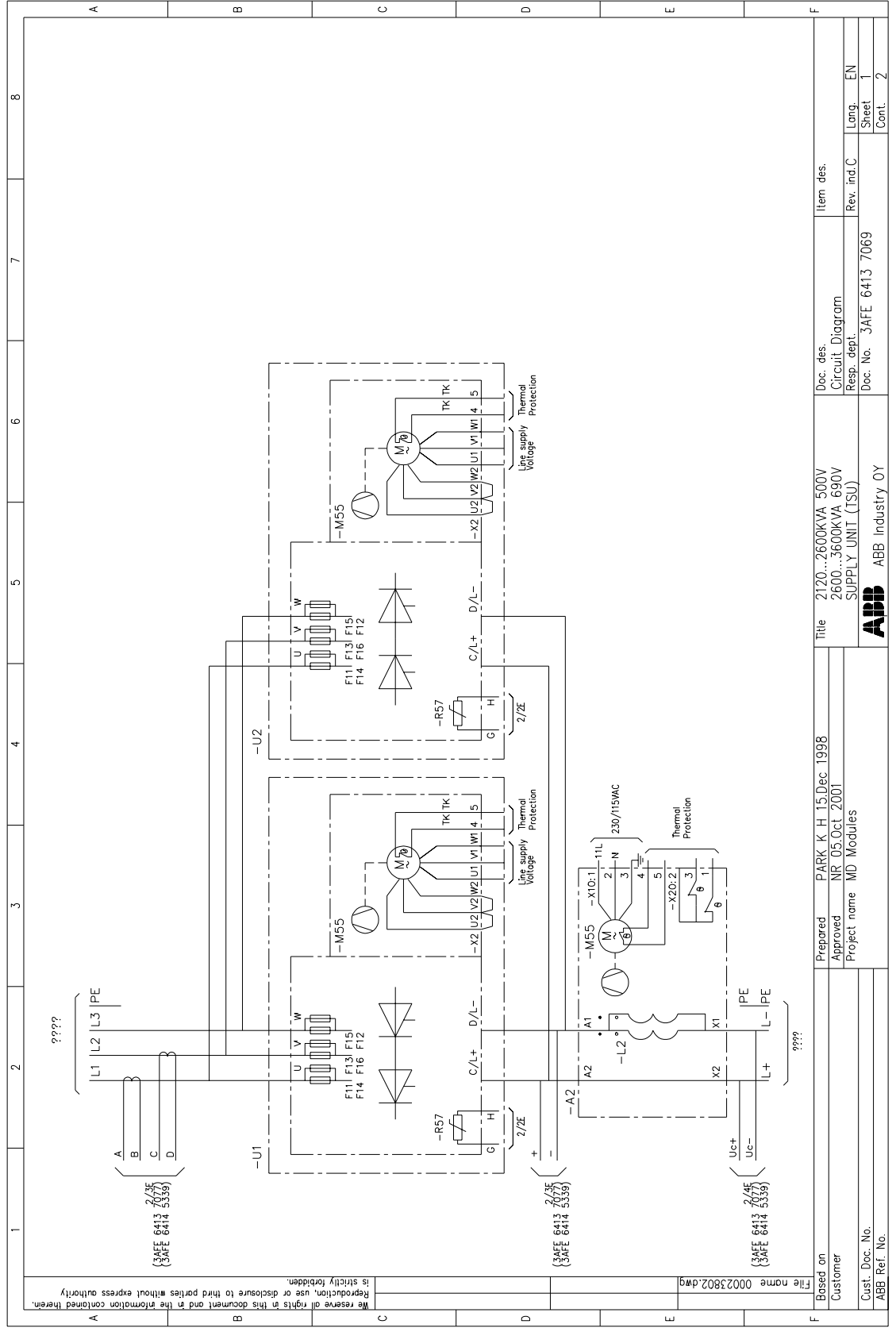


The name 00023800.dwg  
 Title  
 Based on  
 Customer  
 Cust. Doc. No.  
 ABB Ref. No.

Prepared	PARK K H 15.Dec 1998	Doc. des.	850...1400KVA 500V	Item des.	
Approved	NR 10.Oct 2001	Circuit Diagram	850...1400KVA 690V	Resp. ind.C	
Project name	MD Modules	Doc. No.	3AFE 6413 7026	Lang.	EN
				Sheet	1
				Cont.	2

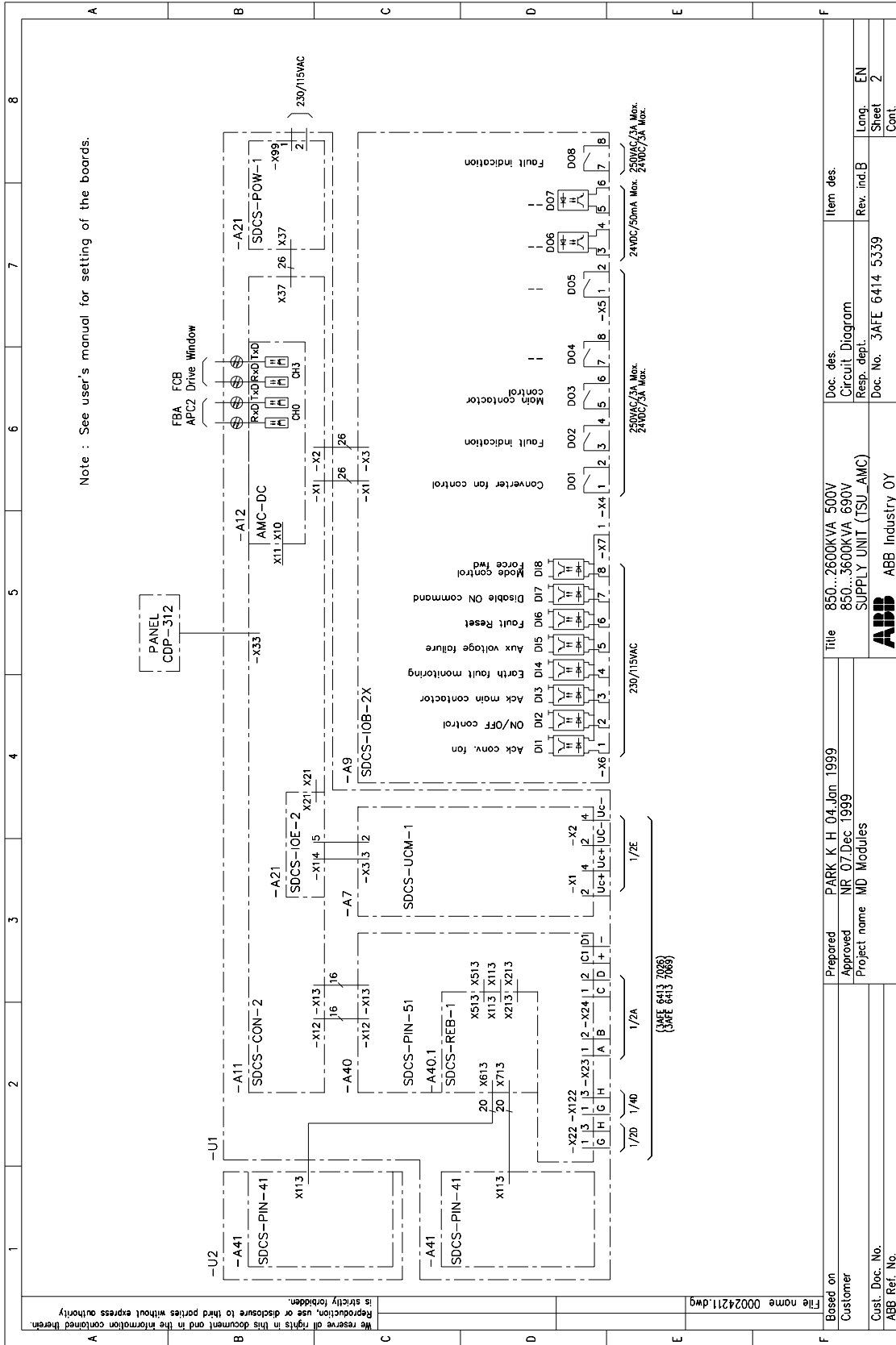


ABB industry OY

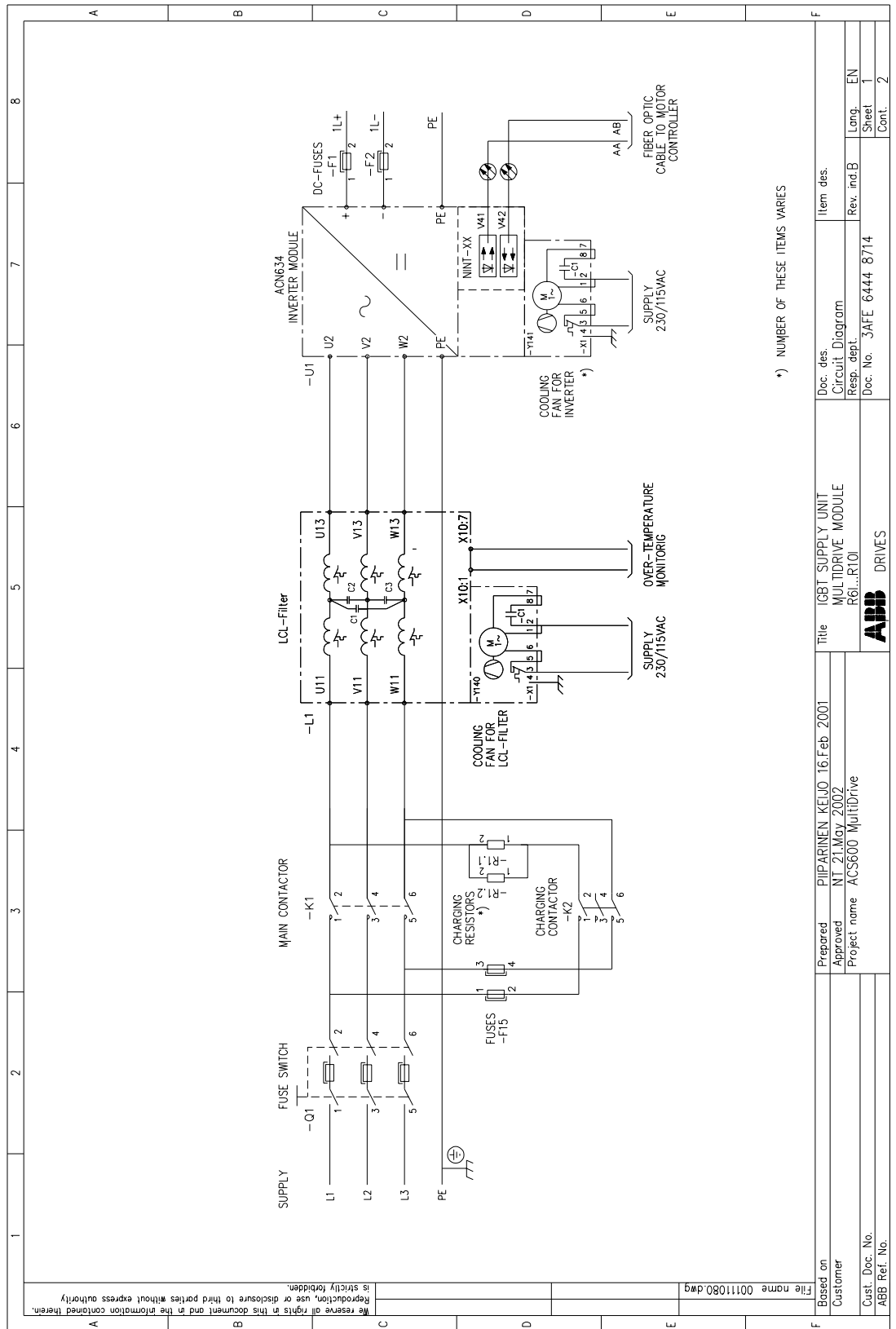


We reserve all rights in this document and in the information contained therein. Reproduction, use or disclosure to third parties without express authority is strictly forbidden.

File name	00023802.dwg
Based on	
Customer	
Cust. Doc. No.	
ABB Ref. No.	
Prepared	PARK, K. H. 15. Dec. 1998
Approved	NR 05. Oct. 2001
Project name	MD Modules
Title	2120...2600KVA 500V 2600...3600KVA 690V SUPPLY UNIT (TSU)
Doc. des.	Circuit Diagram
Resp. dept.	
Doc. No.	3AFE 6413 7069
Item des.	
Rev. ind. C	
Lang.	EN
Sheet	1
Cont.	2



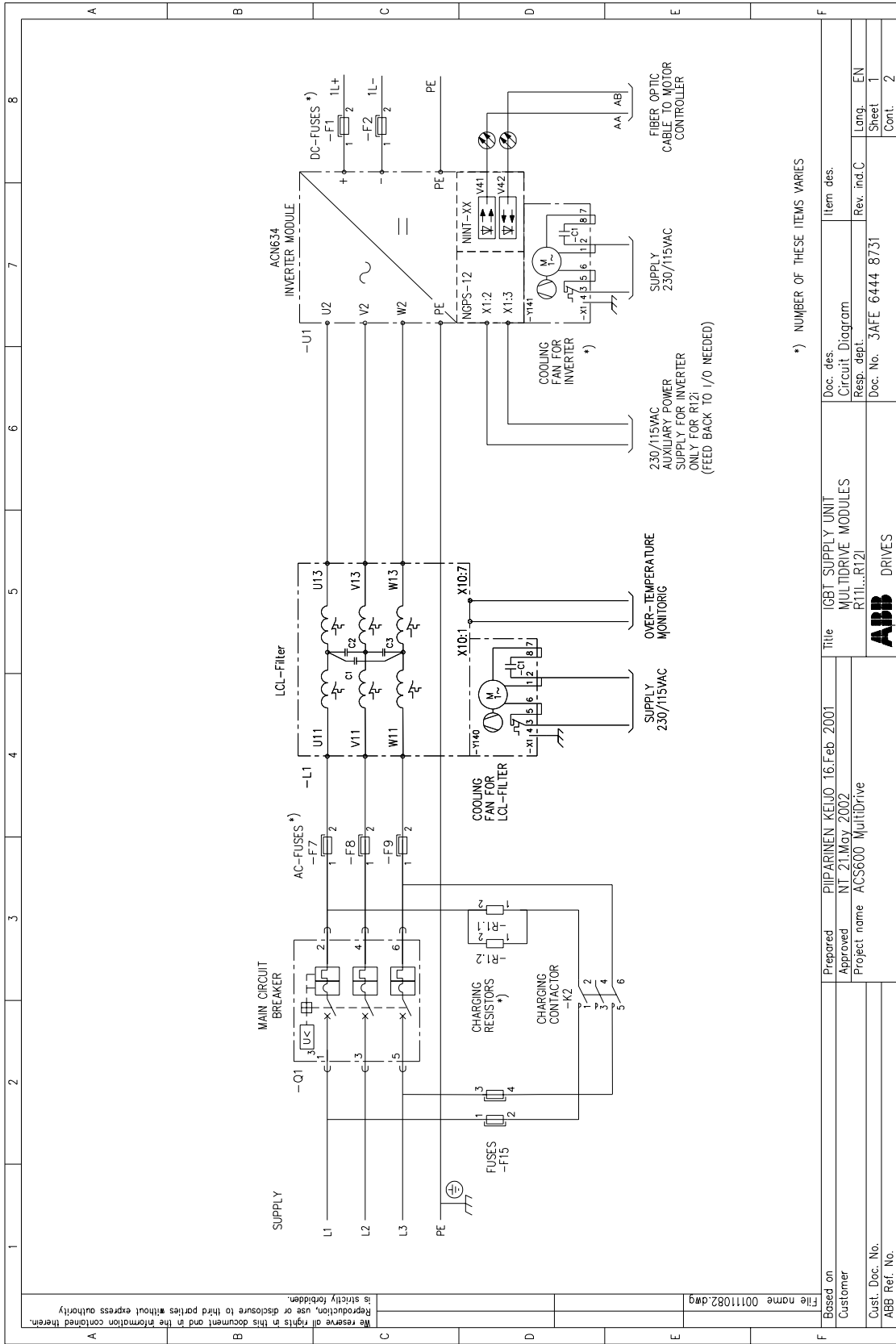
IGBT Supply Units



\*) NUMBER OF THESE ITEMS VARIES

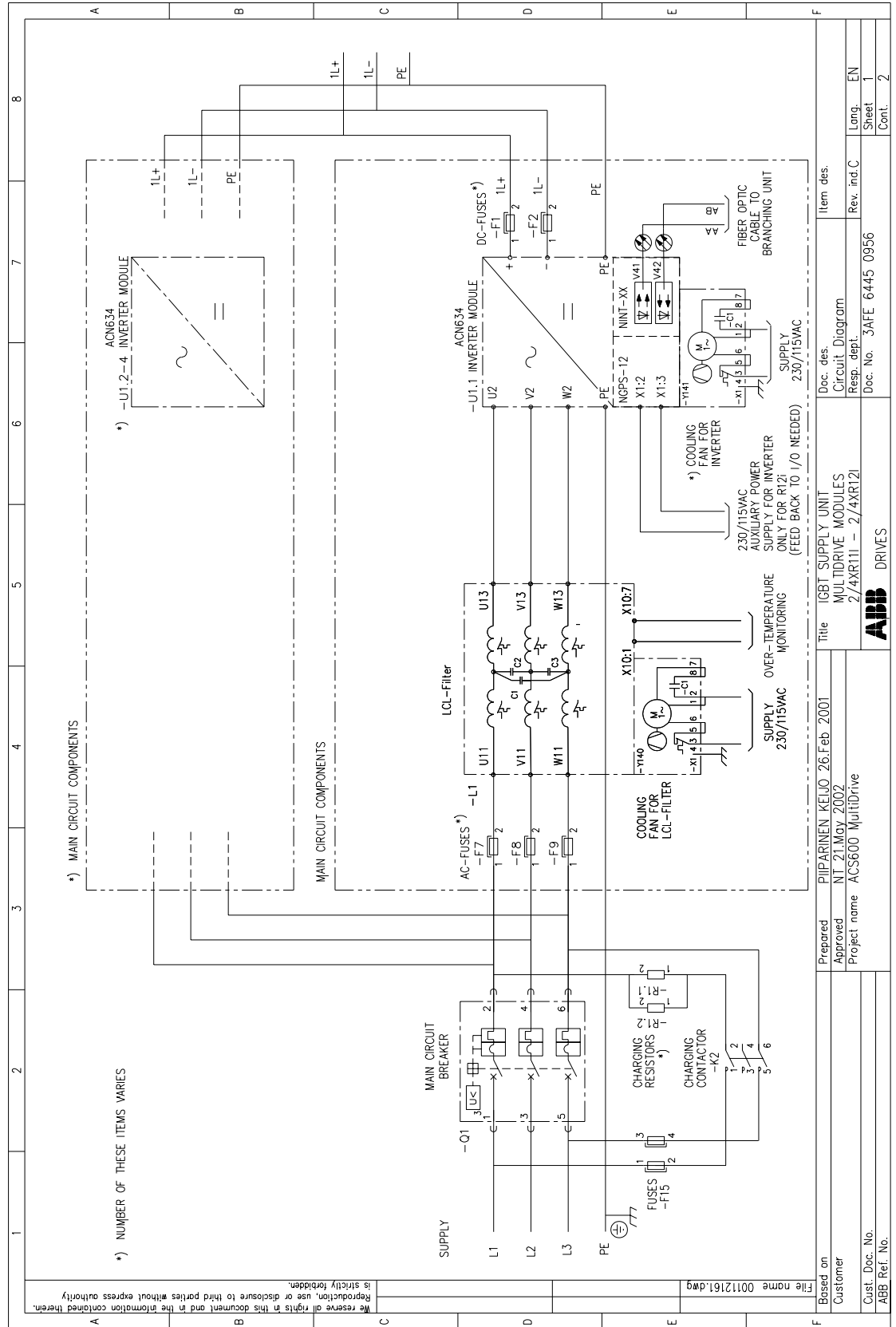
File name 00111080.dwg  
 Based on  
 Customer  
 Cust. Doc. No.  
 ABB Ref. No.

Prepared	PIIPARINEN KEIJO 16.Feb. 2001	Title	IGBT SUPPLY UNIT	Doc. des.	Item des.
Approved	NT 21.May 2002		MULTIDRIVE MODULE	Circuit Diagram	
Project name	ACS600 MultiDrive		RG...RTOI	Resp. dept.	Rev. ind.B
					Long. EN
					Sheet 1
					Cont. 2



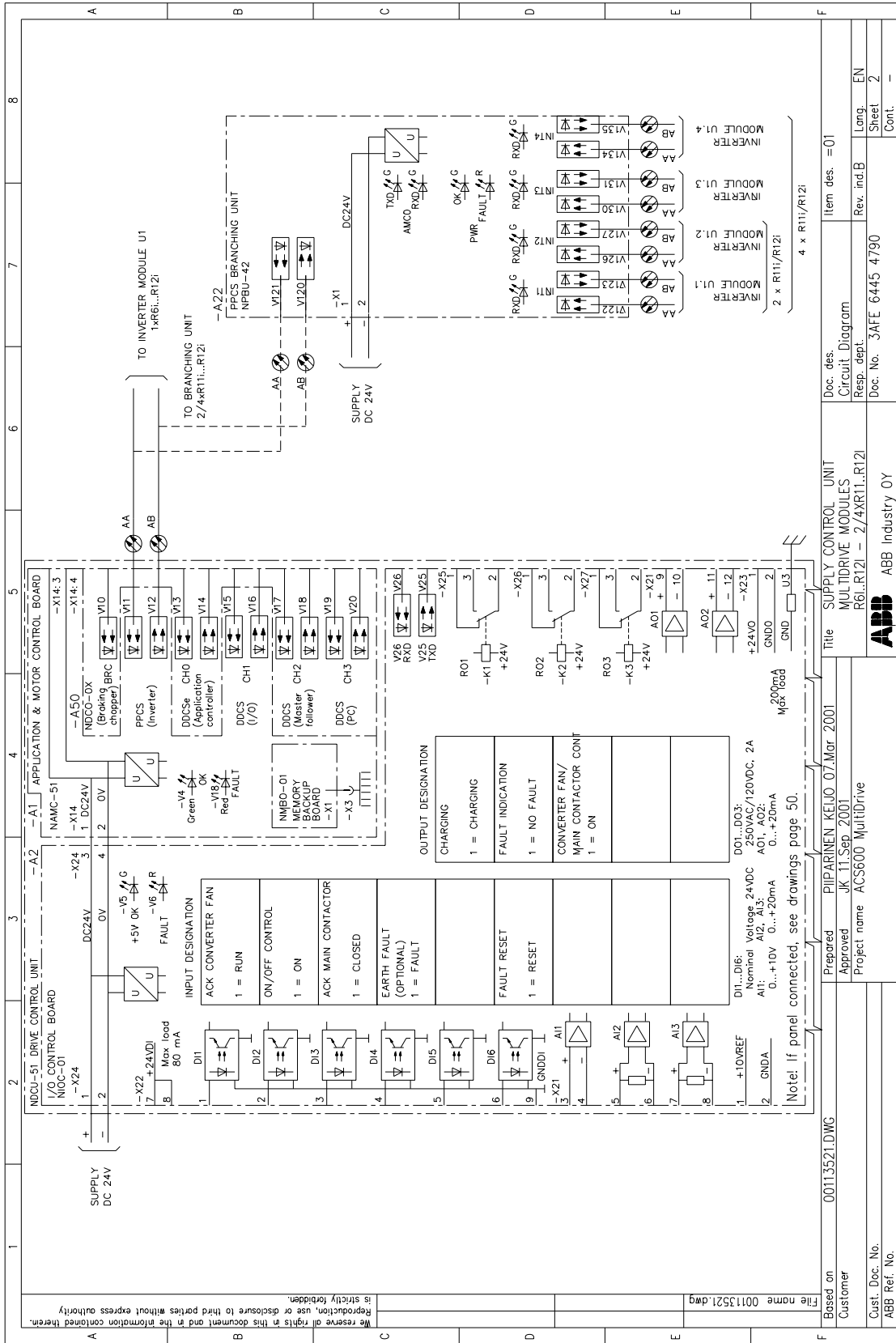
\*) NUMBER OF THESE ITEMS VARIES

File name	00111082.dwg
Based on	
Customer	
Prepared	PIIPARINEN KEIJO 16.Feb.2001
Approved	NI 21.May.2002
Project name	ACS600 MultiDrive
Doc. No.	3AFE 6444 8731
Rev. ind.C	
Long	EN
Sheet	1
Cont.	2



We reserve all rights in this document and in the information contained therein. Reproduction, use or disclosure to third parties without express authority is strictly forbidden.

File name	0012161.dwg
Based on	
Customer	
Cust. Doc. No.	ABB Ref. No.
Prepared	PIIPARINEN, KEIJO, 26.Feb. 2001
Approved	NI, 21.May 2002
Project name	ACS600 MultiDrive
Title	IGBT SUPPLY UNIT MULTIDRIVE MODULES 2/4XR111 - 2/4XR121
Doc. des.	Circuit Diagram
Item des.	
Rev. ind. C	Lang. EN
Doc. No. 3AFE 6445 0956	Sheet 1
	Cont. 2



Doc. des.	Item des. =01
Circuit Diagram	
Resp. dept.	Rev. ind.B
Doc. No. 3AFE 6445 4790	Lang. EN
	Sheet 2
	Cont. -

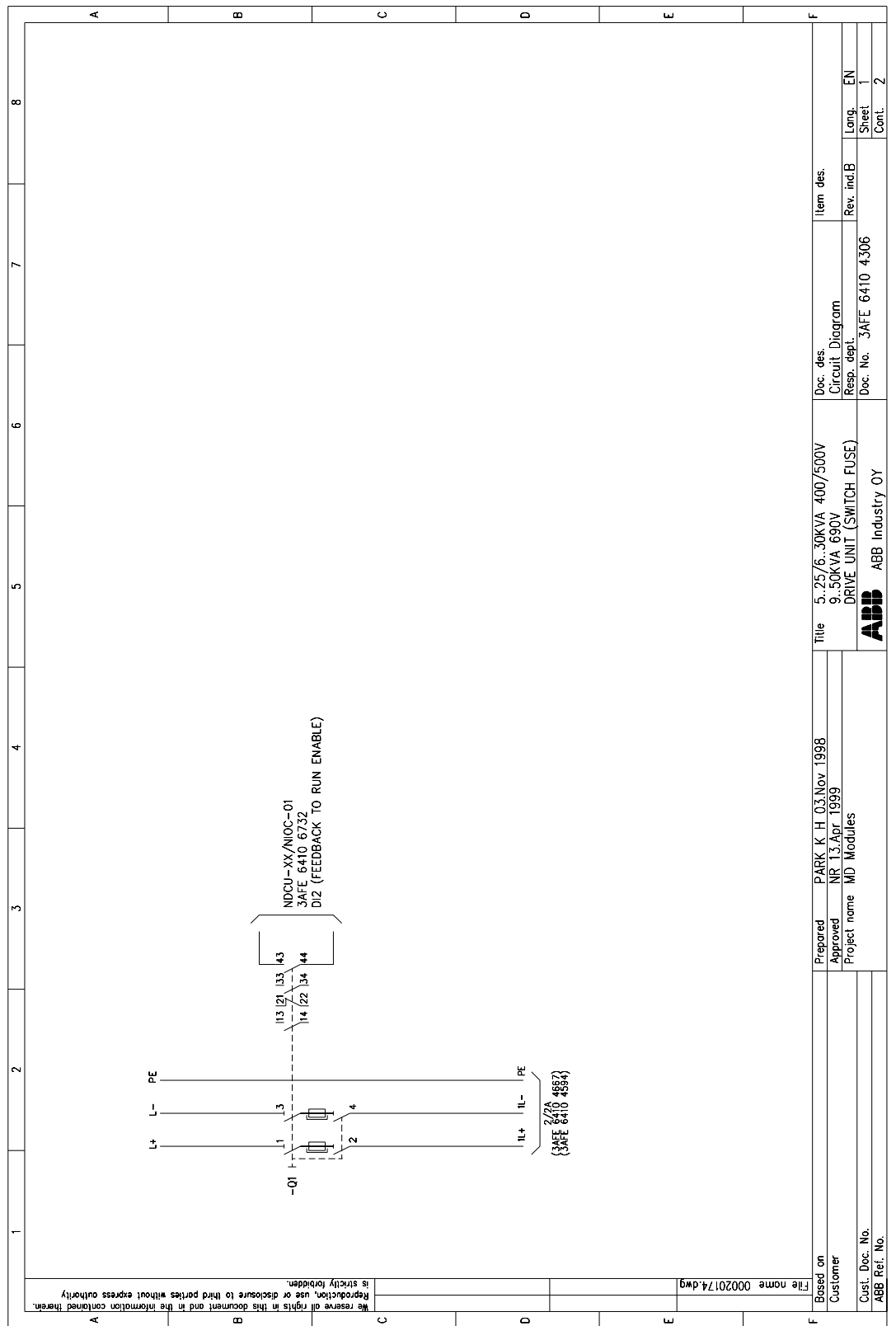
Title	SUPPLY CONTROL UNIT MULTIDRIVE MODULES R6i.R12i - 2/4XR11...R12i
Prepared	PIIPARINEN KEIJO 07.Mar.2001
Approved	JK 11.Sep.2001
Project name	ACS600 MultiDrive

Based on	00113521.DWG
Customer	
Cust. Doc. No.	
ABB Ref. No.	

File name 00113521.dwg  
 We reserve all rights in this document and in the information contained therein. Reproduction, use or disclosure to third parties without express authority is strictly forbidden.

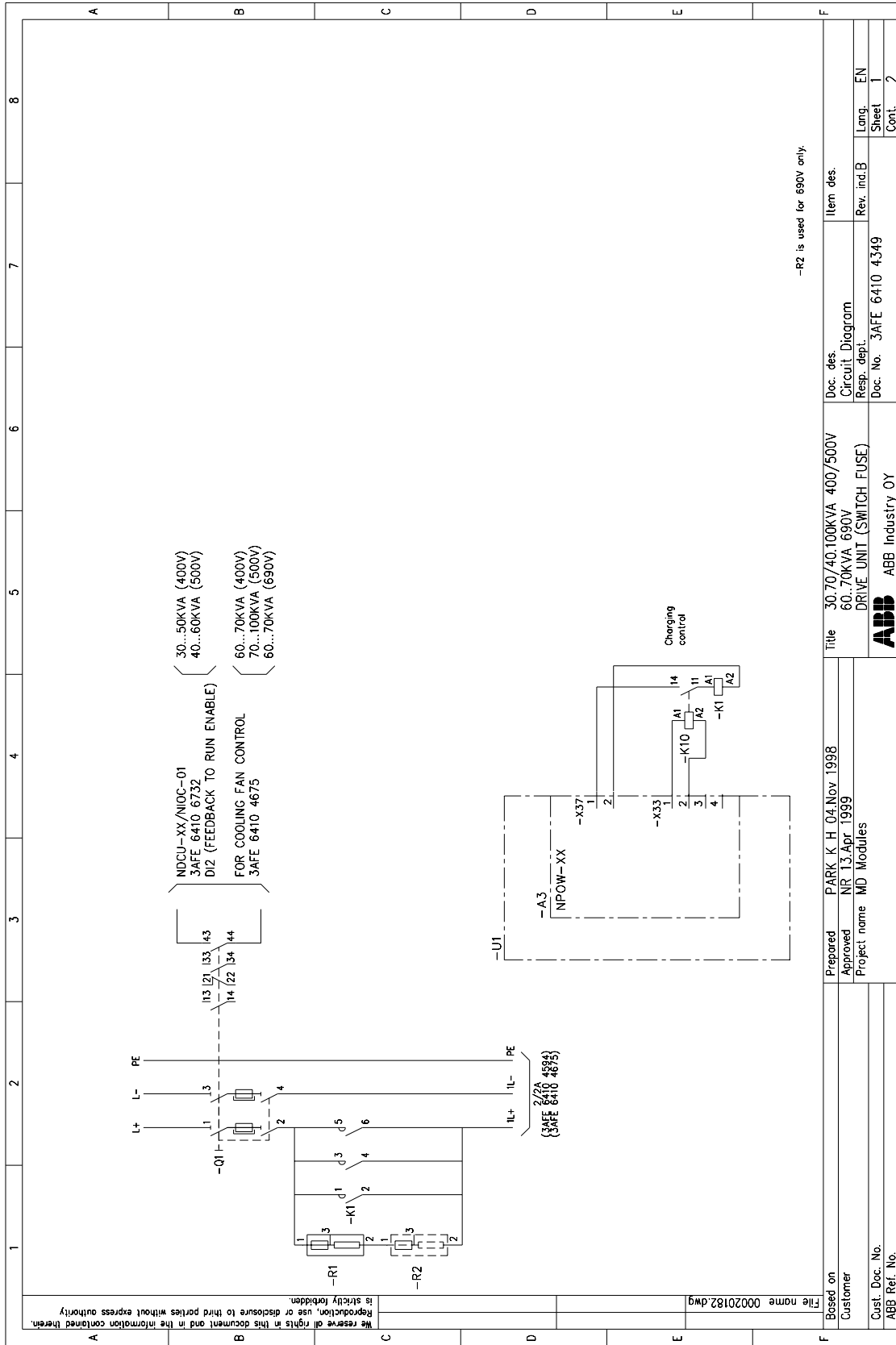


### Switch Fuses with Charging Circuitry

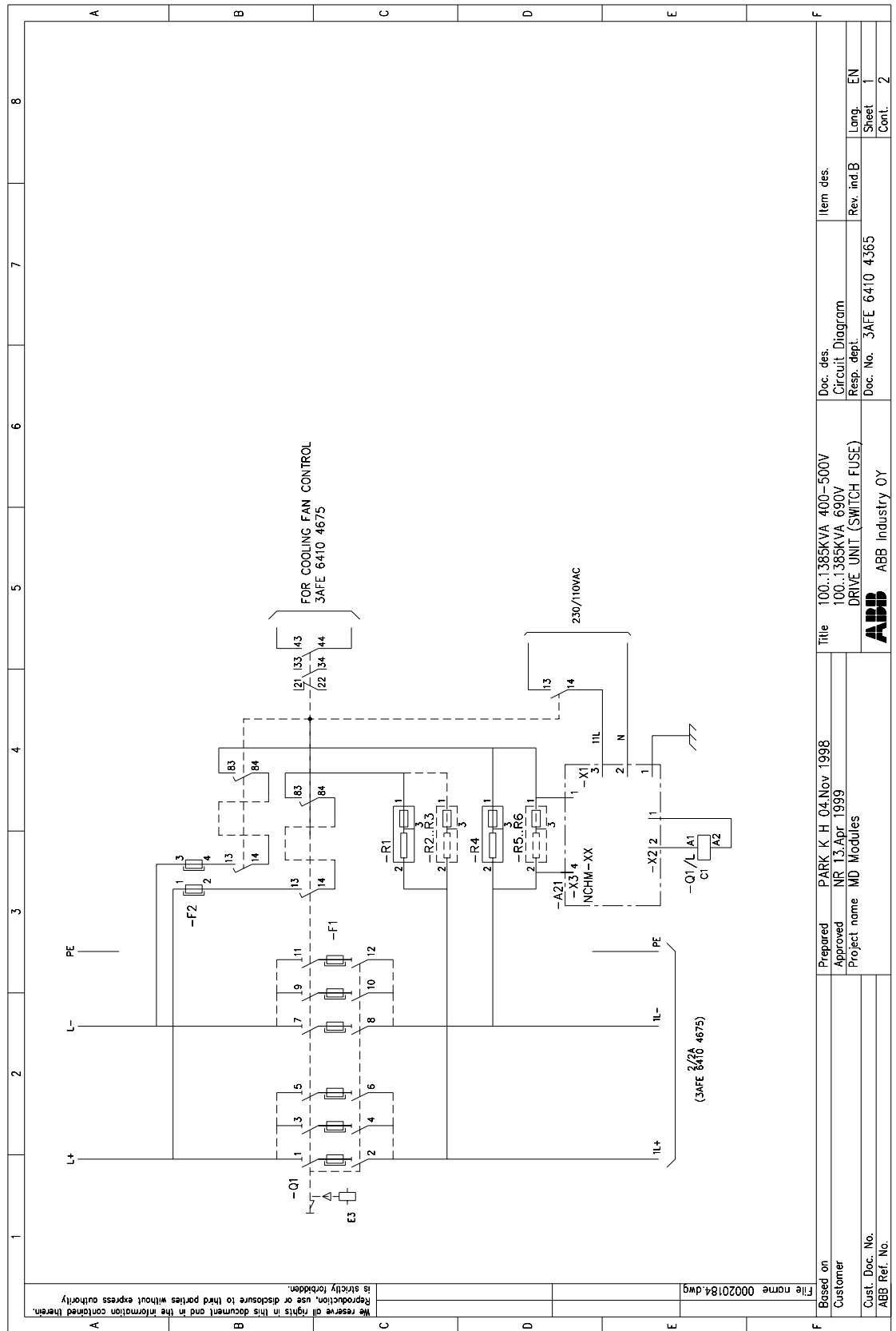


We reserve all rights in this document and in the information contained therein. Reproduction, use or disclosure to third parties without express authority is strictly forbidden.

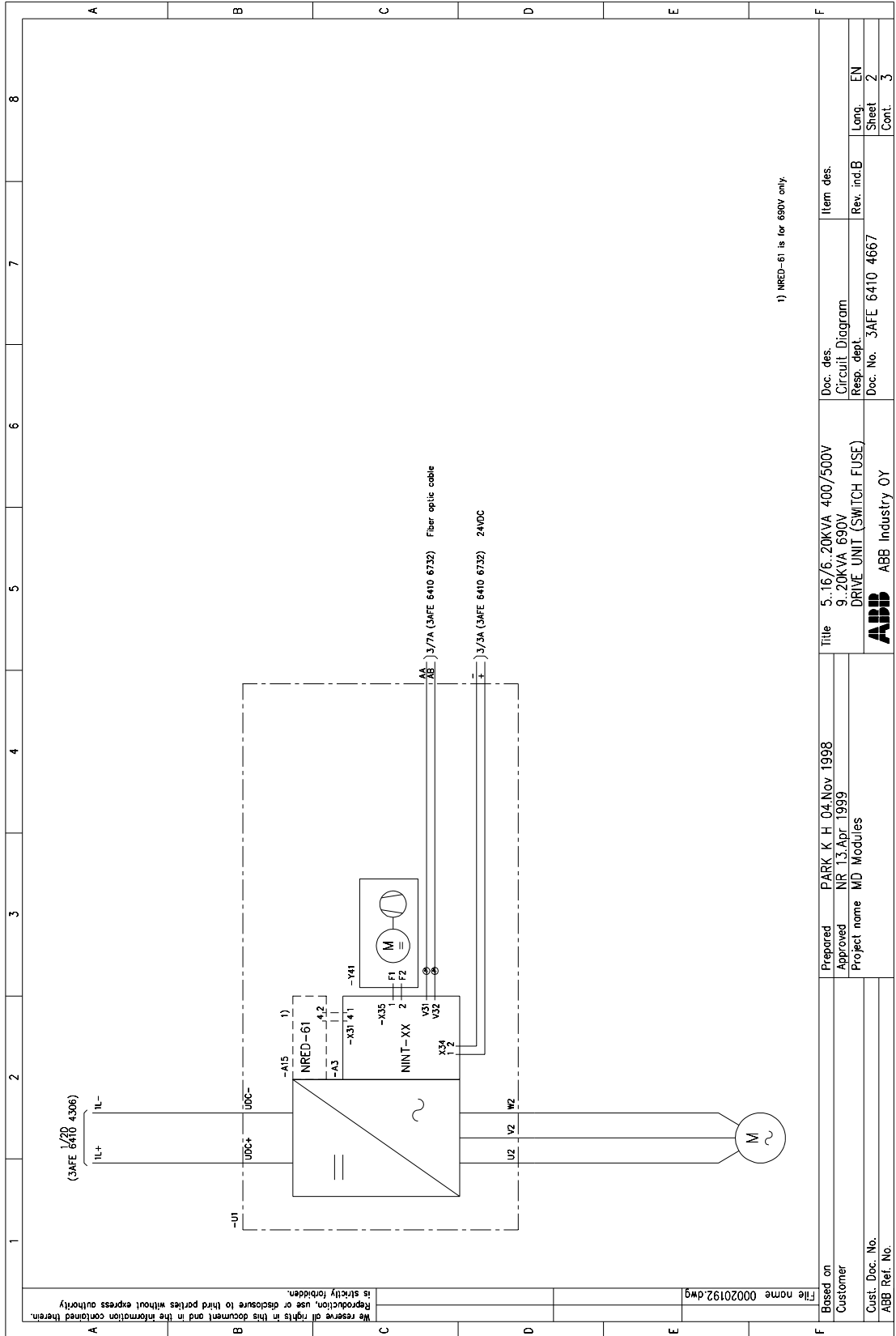
File name	00020174.dwg
Based on	
Customer	
Cust. Dec. No.	
ABB Ref. No.	
Prepared	PARK, K. H. 03.Nov. 1998
Approved	NR 13.Apr. 1999
Project name	MD Modules
Title	5, 25/6, 30KVA 400/500V 9, 50KVA 690V DRIVE UNIT (SWITCH FUSE)
Doc. des.	Circuit Diagram
Resp. dept.	
Doc. No.	SAFE 6410 4306
Item des.	
Rev. ind.B	
Rev. ind.B	
Lang.	EN
Sheet	1
Cont.	2

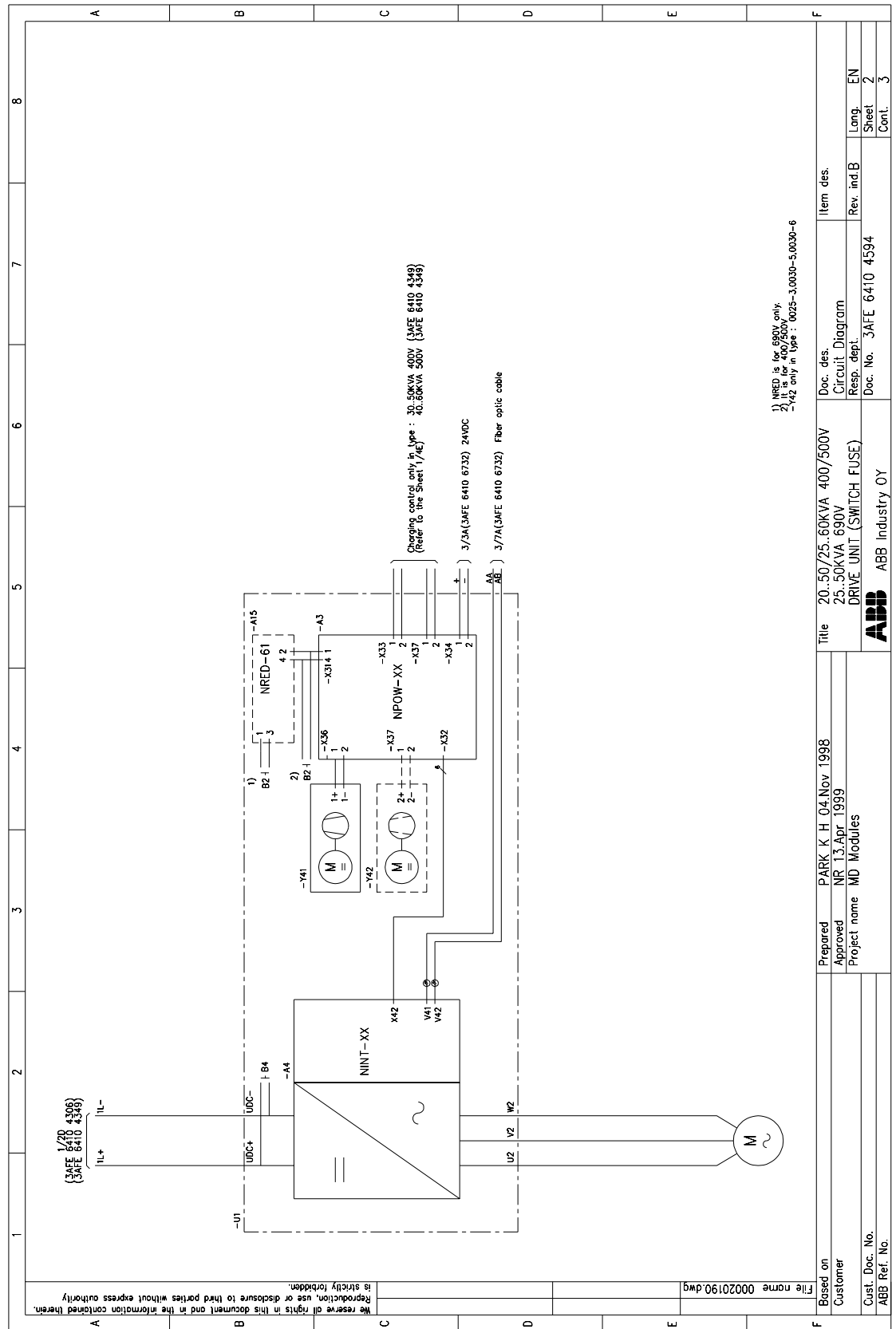


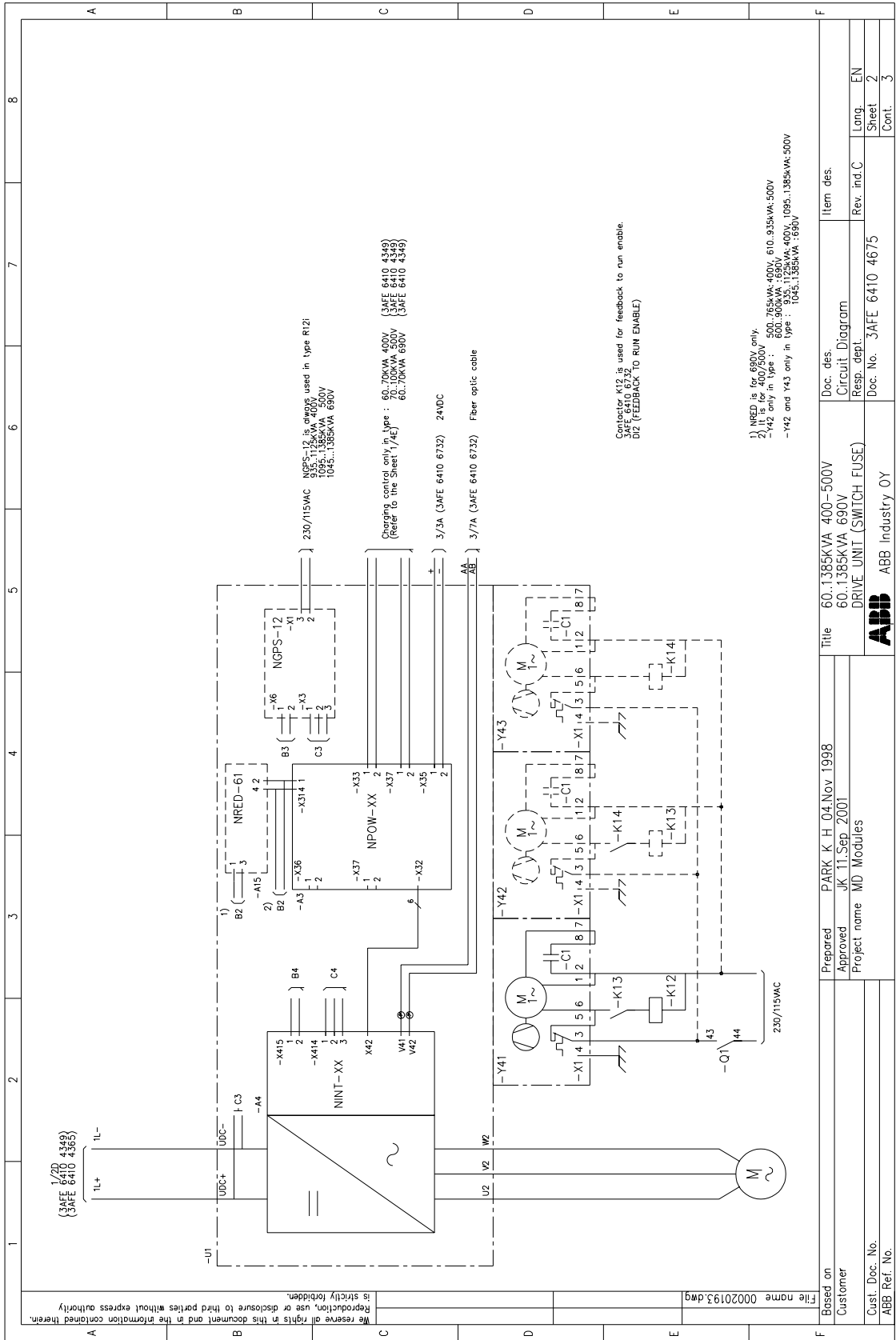
-R2 is used for 690V only.



Drive Units



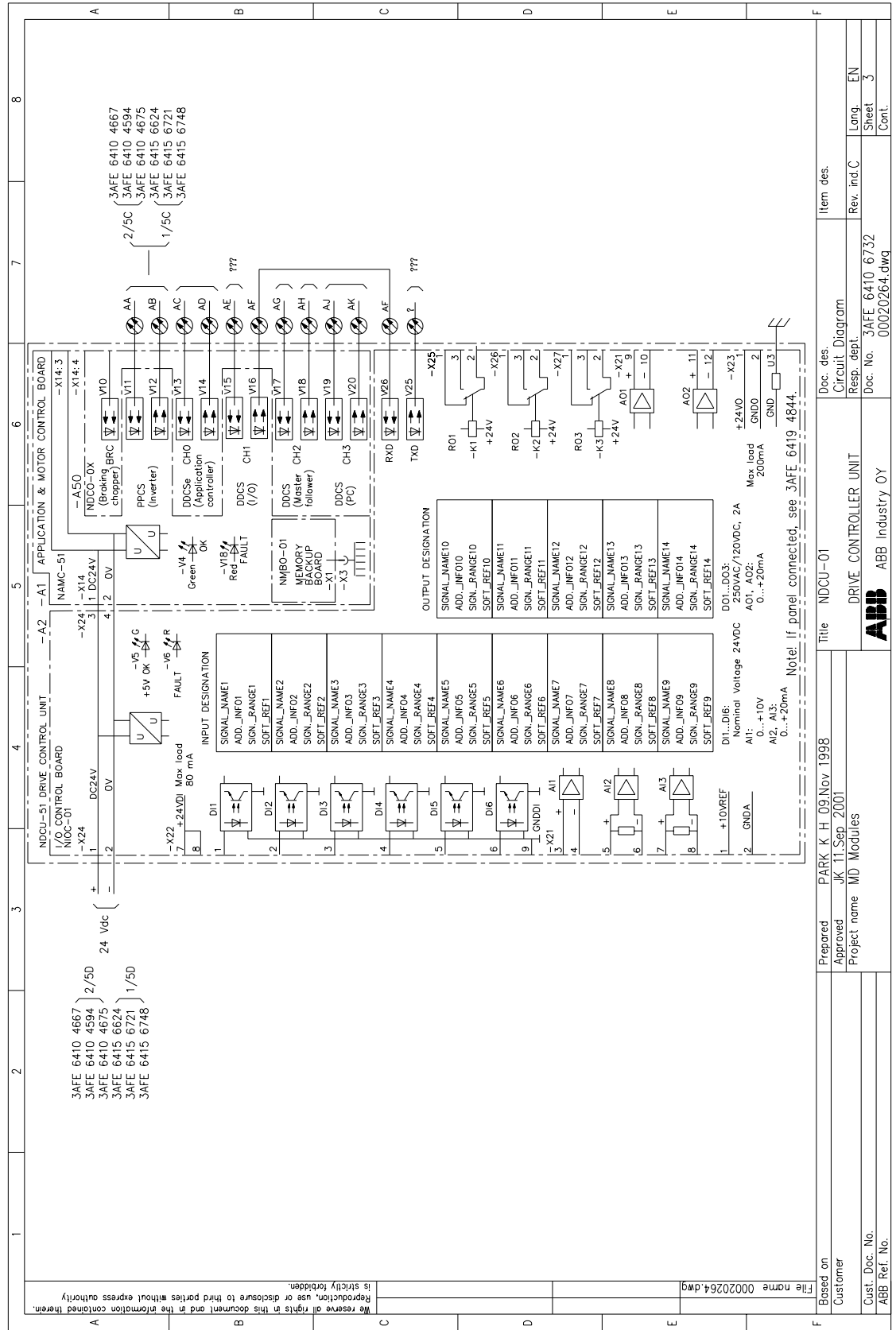




We reserve all rights in this document and in the information contained herein. Reproduction, use or disclosure to third parties without express authority is strictly forbidden.

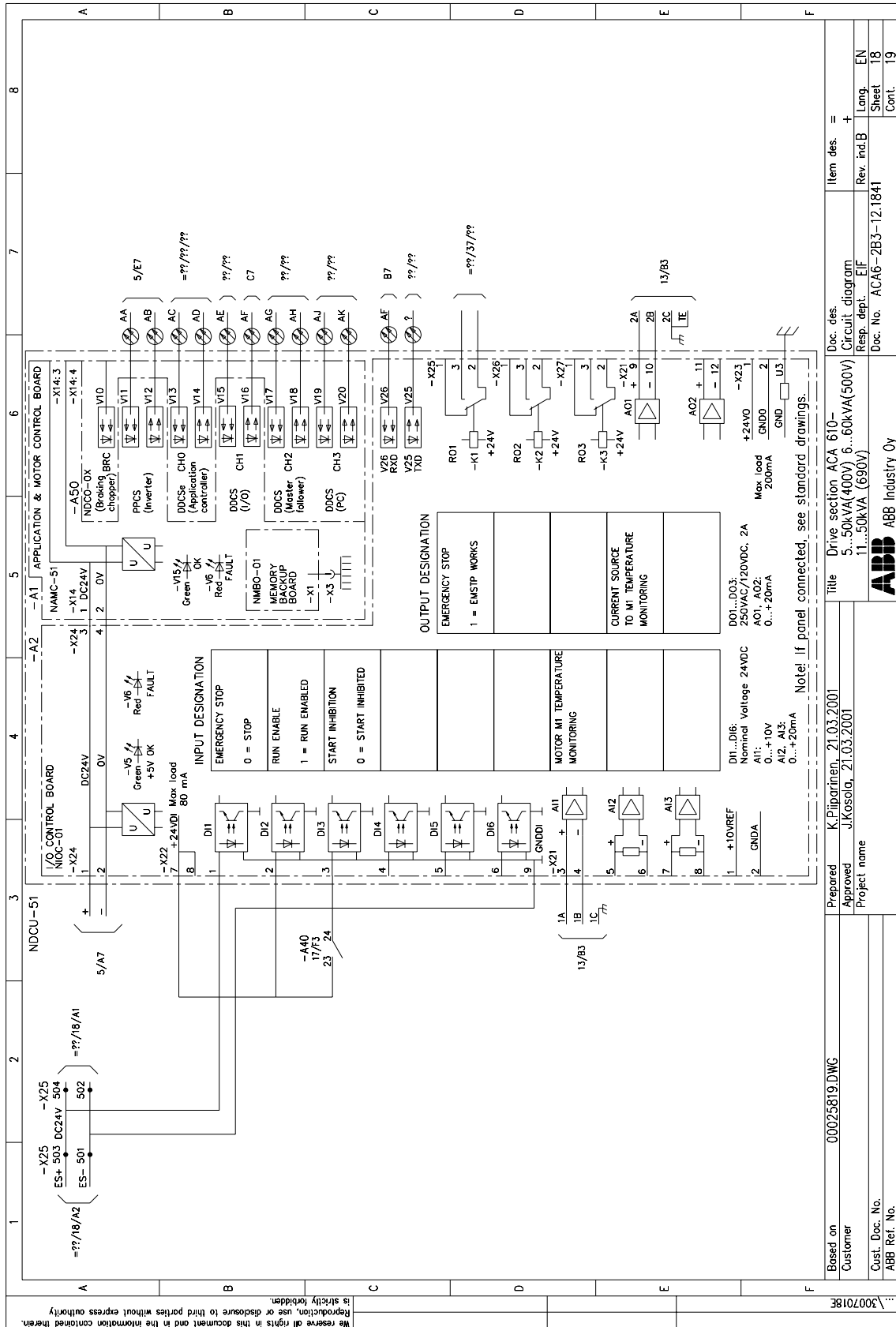
File name 00020193.dwg

Based on	Prepared	PARK K H 04.Nov.1998	Title	60.1385kVA 400-500V	Doc. des.	Item des.
Customer	Approved	JK T1.Sep.2001	60.1385kVA 690V	Circuit Diagram	Rev. ind.C	Lang. EN
Cust. Doc. No.	Project name	MD Modules	DRIVE UNIT (SWITCH FUSE)	Doc. No.	SAFE 6410 4675	Sheet 2
ABB Ref. No.	ABB Industry OY				Doc. No.	Cont. 3

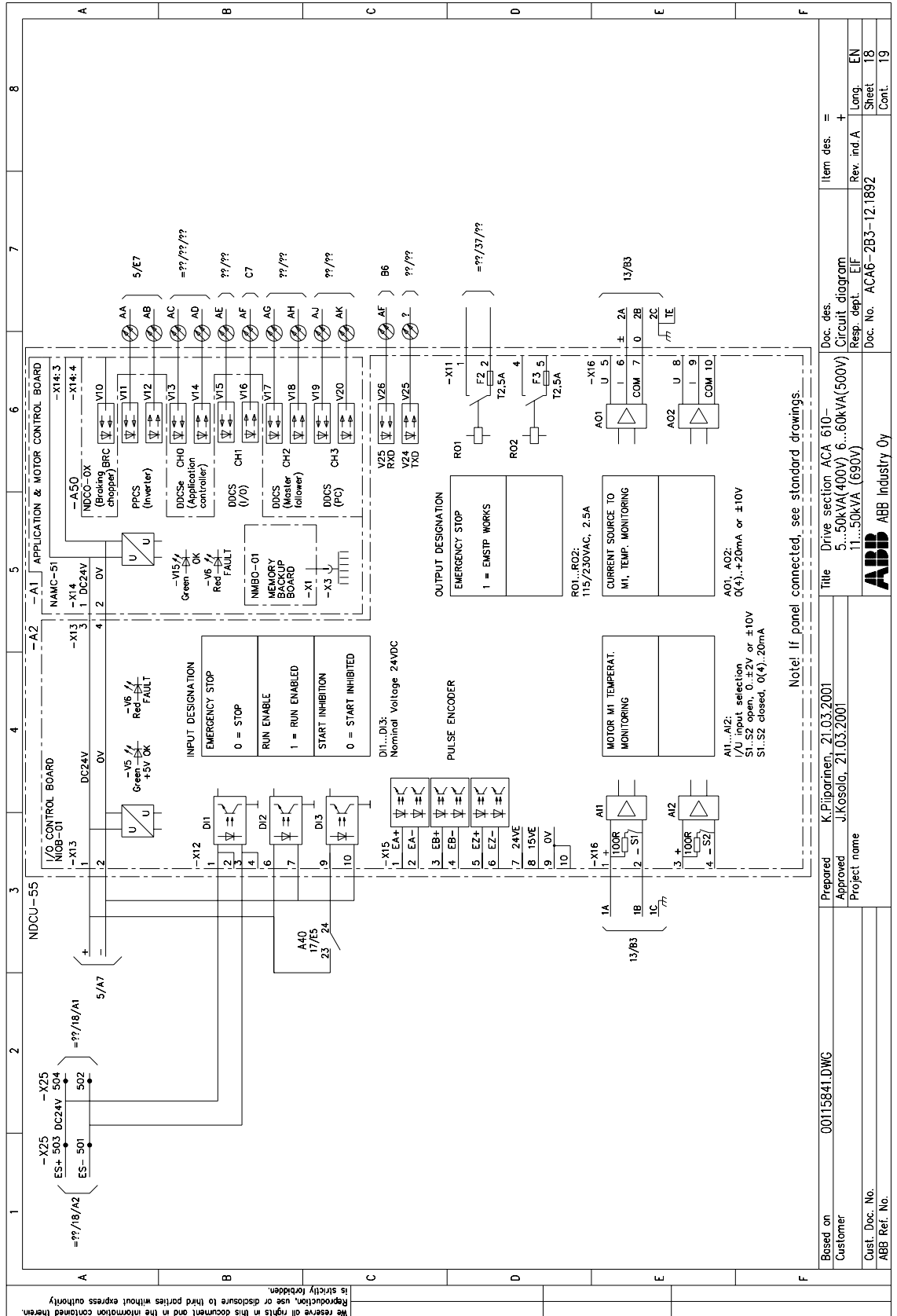


We reserve all rights in this document and in the information contained therein. Reproduction, use or disclosure to third parties without express authority is strictly forbidden.

File name	00020264.dwg
Based on	PARK K H 09.Nov.1998
Customer	JK 11.Sep.2001
Project name	MD Modules
Cust. Doc. No.	3AFE 6410 6732
ABB Ref. No.	00020264.dwg
Prepared	PARK K H 09.Nov.1998
Approved	JK 11.Sep.2001
Project name	MD Modules
Title	NDCU-01
Doc. des.	Circuit Diagram
Item des.	DRIVE CONTROLLER UNIT
Rev. ind. C	3AFE 6410 6732
Lang.	EN
Sheet	3
Cont.	



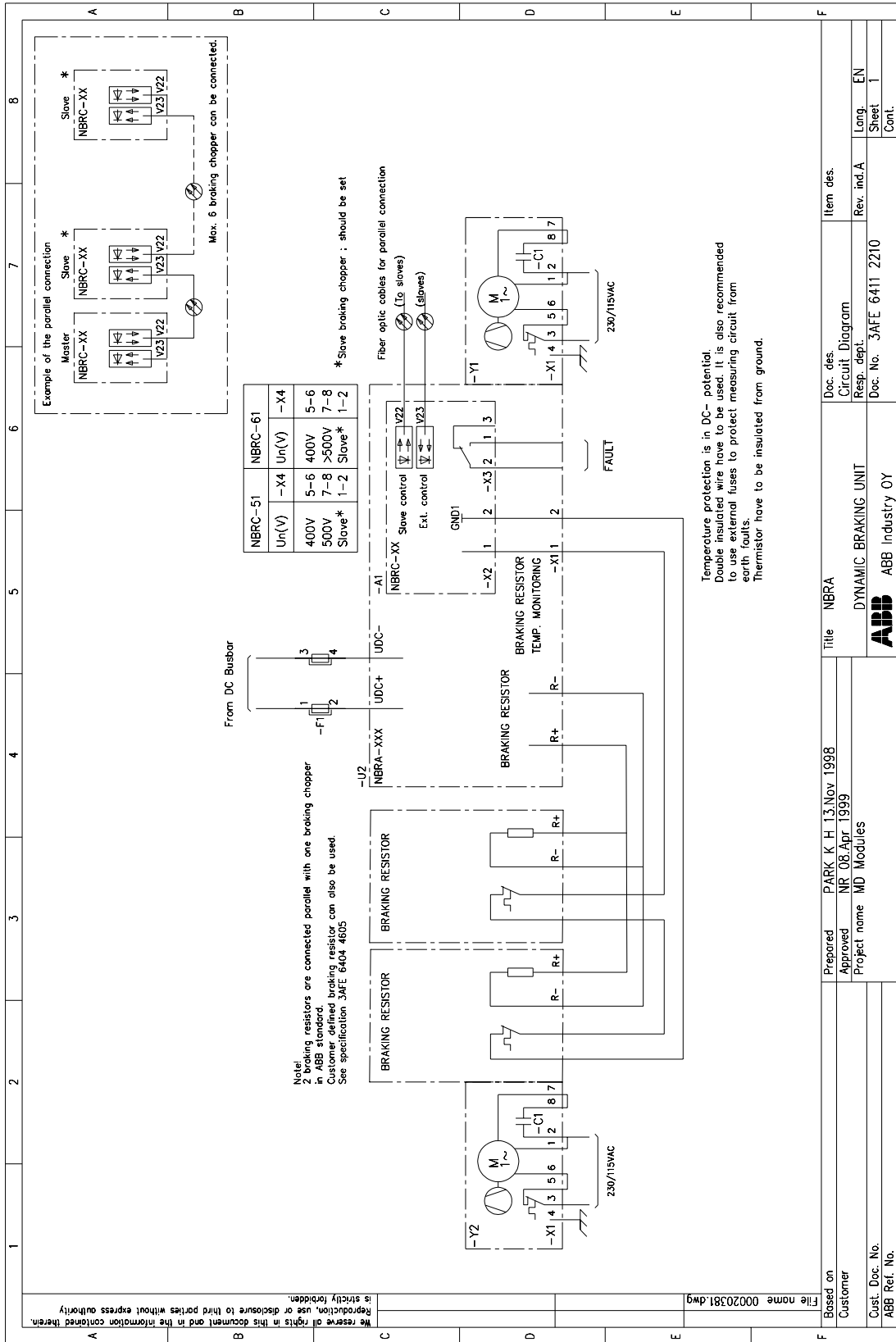




We reserve all rights in this document and in the information contained herein. Reproduction, use or disclosure to third parties without express authority is strictly forbidden.

Based on	00115841.DWG	Prepared	K.Piiparinen, 21.03.2001	Title	Drive section ACA 610-	Doc. des.	Circuit diagram	Item des.	=
Customer		Approved	J.Koskela, 21.03.2001		5...50kVA(400V) 6...60kVA(500V)	Responsible	EIF	Rev. ind. A	Long. EN
Cust. Doc. No.		Project name			11...50kVA (690V)	Doc. No.	ACA6-2B3-12.1892	Rev. ind. A	Sheet 18
ABB Ref. No.								Rev. ind. A	Cont. 19

# Dynamic Braking Unit



Based on	Customer	Prepared	PARK K H 13.Nov.1998	Title	NBRA	Doc. des.	Item des.
Customer		Approved	NR 08.Apr.1999	DYNAMIC BRAKING UNIT		Circuit Diagram	
Cust. Doc. No.		Project name	MD Modules	ABB		Resp. dept.	Rev. ind.A
ABB Ref. No.				ABB Industry OY		Doc. No.	SAFE 6411 2210
						Lang.	EN
						Sheet	1
						Cont.	

# Appendix B – Type Code Key

- 1 **A** **Product Category**  
A = AC Drive
- 2..3 **C N** **Product Type**  
CN = MultiDrive Module construction
- 4 **6** **Product Family**  
6 = ACS 600
- 5  **Type**  
3 = Inverter module / IGBT supply module  
4 = Inverter phase module  
5 = Thyristor supply module / Forward (TSU)  
6 = Thyristor supply module / Reverse (TSU)  
7 = 4Q Thyristor supply module (TSU)  
8 = Diode supply module (DSU)
- 6 **4** **Construction**  
4 = Module
- 7..10  **Power Rating (kVA)**

Frame size:	Diode Supply Modules							
	B2		B3		B4		B5	
500 V:	0175	0250	0375	0525	0855	1405	2120	2600
690 V:	0090	0175	0375	0525	0855	1405	2600	3600
	0250							

Frame size:	Thyristor Supply Modules									
	B1		B2		B3		B4		B5	
500 V:	0016	0032	0175	0250	0375	0525	0855	1405	2120	2600
690 V:	0047	0088	0090	0175	0375	0525	0855	1405	2600	3600
830 V:			0250				1685		3100	3520
									4310	

Frame size:	Inverter Modules														
	R2i			R3i			R4i		R5i			R6i		R7i	
(380-415V):	0005	0006	0009	0011	0016	0020	0025	0030	0040	0050	0060	0070	0100	0120	
(380-500V):	0006	0009	0011	0016	0020	0025	0030	0040	0050	0060	0070	0100	0120	0140	
(525-690V):				0009	0011	0016	0020	0025	0030	0040	0050	0060	0070	0100	0120

Frame size:	R8i			R9i		R10i		R11i		R12i	
	(380-415V):	0185	0225	0265	0335	0405	0505	0635	0755	0935	1125
(380-500V):	0215	0255	0325	0395	0495	0615	0775	0925	1095	1385	
(525-690V):	0185	0205	0255	0315	0375	0485	0605	0755	0905	1045	1385

- 11  **Voltage Rating**  
3 = 380, 400, 415 V  
5 = 440, 460, 500 V  
6 = 525, 575, 600, 660, 690 V  
8 = 830 V / Not Applicable to Inverter Modules (R2i - R12i)
- 12...15  **Reserved**  
0 = Default
- 16  **Parallel Unit**  
0 = U,W-Phase module (R10i - R12i) / Default for TSU, DSU, R2i - R9i  
3 = V-Phase module (R10i - R12i) / Not Applicable to TSU, DSU, R2i - R9i

Appendix B – Type Code Key

17	<input type="checkbox"/>	<b>Degree of Protection</b> 0 = IP00 3 = IP00 with Coated boards
18	<input type="checkbox"/>	<b>Reserved</b> 0 = Default
19	<input type="checkbox"/>	<b>Fan Supply</b> 0 = 230V (B1-B4) or 380-690V (B5) / Default for inverters (R2i-R12i) A = 115V (B2-B4) / Not Applicable to inverters (R2i-R12i)
20	<input type="checkbox"/>	<b>EMC Filters</b> 9 = No internal EMC filter board, Default
21	<input type="checkbox"/>	<b>Reserved</b> 0 = Default
22	<input type="checkbox"/>	<b>Other Options</b> 0 = None 1 = Not used anymore 2 = Prevention of unexpected start-up (NGPS) board included (ACN634/644, R10i - R11i V-phase, R2i - R9i) / R12i always included / Not Applicable to TSU, DSU 3 = Not used anymore 4 = DSU (NDSC-01) / TSU (CON-1 + COM1) control included (HW&SW) / Not Applicable to inverters 5 = 4 + varistors (U,max = 600V) in ACN654/684 / Not Applicable to inverters 6 = TSU (CON-2 + AMC) control included (HW&SW) / Not Applicable to inverters 7 = 6 + varistors (U,max = 600V) in ACN654 / Not Applicable to inverters





---

**ABB Oy**

Drives

P.O. Box 184

FIN-00381 Helsinki

FINLAND

Telephone: +358 10 22 11

Fax: +358 10 22 22681

Internet: [www.abb.com](http://www.abb.com)

MultiDrive Modules Inst. Manual/EN  
3BFE 64119010 R0325  
EFFECTIVE: 19.9.2002