

Experion PKS
Series C I/O User's Guide

EPDOC-X126-en-500G
February 2018

Release 500

Document	Release	Issue	Date
EPDOC-X126-en-500G	500	0	February 2018

Disclaimer

This document contains Honeywell proprietary information. Information contained herein is to be used solely for the purpose submitted, and no part of this document or its contents shall be reproduced, published, or disclosed to a third party without the express permission of Honeywell International Sàrl.

While this information is presented in good faith and believed to be accurate, Honeywell disclaims the implied warranties of merchantability and fitness for a purpose and makes no express warranties except as may be stated in its written agreement with and for its customer.

In no event is Honeywell liable to anyone for any direct, special, or consequential damages. The information and specifications in this document are subject to change without notice.

Copyright 2018 - Honeywell International Sàrl

Contents

1 About this guide	17
1.1 Intended audience	18
1.2 Prerequisite Skills	19
1.3 References	20
1.4 Terms and acronyms	21
2 Series C I/O Purpose	23
2.1 Comparing Process Manager I/O and Series C I/O	24
2.2 What is Series C I/O?	25
2.3 Series C Pulse Input Module (SCPIM)	26
2.3.1 Features of PIM	26
2.3.2 Comparison between Series A and Series C PIM	26
2.4 What is Universal Input/Output (UIO) Module?	28
2.4.1 Features of UIO	28
2.4.2 UIO features	28
2.4.3 Differences between UIO channels and existing Series C AI, AO, DI, and DO modules	29
2.5 What is Low Level Analog Input (LLAI) Module	30
2.6 Overview of the Universal Horizontal Input/Output (UHIO)	31
2.6.1 Mapping the CB/EC racks with UHIO components	32
2.6.2 Features of UHIO	33
2.6.3 UHIO hardware	34
2.6.4 Differences between the Series C IOTA and the UHIO IOTA	34
2.6.5 About UHIO certification	34
3 Series C I/O Planning and Design	37
3.1 General Planning References	38
3.1.1 Series C I/O appearance	38
3.1.2 Series C I/O features	38
3.2 Series C I/O and C300 topology	42
3.2.1 Examining the topology rules	42
3.3 Supported Series C I/O modules	44
3.3.1 Compatibility matrix between AI modules and differential AI modules	46
3.3.2 Compatibility matrix between AO modules and differential AO modules	47
3.3.3 Difference between AI-HART modules Cx-PAIH01 and Cx-PAIH51	48
3.3.4 Difference between AO-HART modules Cx-PAOH01 and Cx-PAOH51	48
3.3.5 Difference between bussed low voltage Digital Input modules Cx-PDIL01 and Cx-PDIL51	48
3.3.6 Difference between low voltage Digital Output modules Cx-PDOB01 and Cx-PDOD51	49
3.3.7 Difference between AI-LLMUX and CC-PAIL51 modules Cx-PAIM01 and Cx-PAIM51	49
3.3.8 Identifying supported Series C I/O modules	49
3.3.9 Considerations for replacing or pairing Series C Analog I/O modules in a redundant configuration	50
3.4 Supported Series C I/O options	51
3.4.1 Inspecting the I/O library	51
3.4.2 Inspecting IOM function blocks	51
3.4.3 Inspecting channel function blocks	52
3.4.4 Defining module containment	53
3.4.5 Temperature Derating for UIO	54

3.4.6	Internal dissipation calculation for UIO	54
3.4.7	Temperature Derating curves for UIO	55
3.4.8	Maximum Temperature Alarm for UIO-2	55
3.4.9	High Temperature Limit Calculation for UIO-2	56
3.5	I/O Link performance specifications	57
3.5.1	Reviewing Link Unit utilization	57
3.5.2	Reducing I/O Link traffic	57
3.5.3	Event collection	58
3.5.4	PV and Back calculation scanning	58
3.6	Universal Input/Output Module-2 (UIO-2)	59
3.6.1	New and enhanced features of UIO-2	59
3.6.2	UIO-2 and UIO-1 compared	59
4	Series C I/O Installation and Upgrades	61
4.1	Installation Declarations	62
4.1.1	Introduction	62
4.1.2	I/O Link Address Jumpers	63
4.1.3	Cabling	63
4.2	Installing the Series C IOTA on the carrier	65
4.3	Mounting the I/O module on the IOTA	67
4.4	Grounding and power considerations - IOTA boards	68
4.4.1	Testing for power	68
4.5	Connecting IOMs and field devices through I/O Termination Assemblies	70
4.6	Powering the Series C system	74
4.7	Fusing - Series C IOTA boards	75
5	Series C IOTA Pinouts	77
5.1	Analog Input IOTA Models CC-TAIX01, CC-TAIX11	78
5.1.1	Field wiring and module protection - Analog Input module	80
5.1.2	Two-wire transmitter wiring - Analog Input module	81
5.1.3	Non two-wire transmitter wiring - Analog Input module	81
5.1.4	Custom wiring - Analog Input module	81
5.1.5	Analog Input wiring reference table	85
5.1.6	Allowable field wiring resistance - Analog Input module	86
5.1.7	IOTA board and connections - Analog Input module	86
5.2	Analog Input non-HART/HARTIOTA Models Cx-TAIX51, Cx-TAIX61	89
5.2.1	Field wiring and module protection - Analog Input HART module	90
5.2.2	Two-wire transmitter wiring - Analog Input HART module	91
5.2.3	Standard and self-powered two-wire transmitter wiring - Analog Input HART module	91
5.2.4	Self-powered 3-wire transmitter (system ground) - Analog Input HART module	92
5.2.5	Analog Input HART module wiring reference table	93
5.2.6	Allowable field wiring resistance - Analog Input HART module	93
5.2.7	IOTA board and connections - Analog Input HART module	93
5.3	Non-HART Analog Input IOTA (Models CC-TAIN01, CC-TAIN11)	95
5.3.1	Field wiring and module protection - non-HART Analog Input module	96
5.3.2	Two-wire transmitter wiring - non-HART Analog Input module	97
5.3.3	Standard and self-powered two-wire transmitter wiring - non-HART Analog Input module	97
5.3.4	Self-powered 3-wire transmitter (system ground) - non-HART Analog Input module	98
5.3.5	Non-HART Analog Input module wiring reference table	99
5.3.6	Allowable field wiring resistance - non-HART Analog Input module	99
5.3.7	IOTA board and connections - non-HART Analog Input module	99
5.4	Differential Analog input IOTA (Models CC-TAID01 and CC-TAID11)	102
5.4.1	Compatible IOTA models for differential analog input and output channels	102
5.4.2	Standard and self-powered two-wire transmitter wiring - Differential Analog input module	102
5.4.3	Custom wiring - Differential Analog input module	104

5.4.4	Jumper configuration for differential configuration - Differential Analog input module	109
5.4.5	IOTA board and connections - Differential Analog input module	111
5.5	Analog Output IOTA Models CC-TAOX01, CC-TAOX11, CC-TAON01 and CC-TAON11	115
5.5.1	Field wiring and module protection - Analog Output module	115
5.5.2	IOTA board and connections - Analog Output module	115
5.5.3	Non-HART Analog Output IOTA (Models CC-TAON01, CC-TAON11)	118
5.5.4	IOTA board and connections - non-HART Analog Output module	118
5.6	Analog Output HART IOTA Models Cx-TAOX51, Cx-TAOX61	122
5.6.1	Field wiring and module protection - Analog Output HART module	122
5.6.2	IOTA board and connections - Analog Output HART module	122
5.7	Low Level Analog Input Mux (LLMUX) IOTA Models CC-TAIM01	126
5.7.1	Field wiring and module protection - Low Level Analog Input Mux (LLMUX) module	126
5.7.2	IOTA board and connections - Low Level Analog Input Mux (LLMUX) module	126
5.8	Digital Input High Voltage IOTA Models CC-TDI110, CC-TDI120, CC-TDI220, CC-TDI230	130
5.8.1	Field wiring and module protection - Digital Input High Voltage module	130
5.8.2	IOTA board and connections - Digital Input High Voltage module	130
5.9	Digital Input High Voltage PROX IOTA Model Cx-TDI151	135
5.9.1	Difference between CC-TDI151 and CC-TDI110/CC-TDI120 IOTAs	135
5.9.2	Field wiring and module protection - Digital Input High Voltage PROX IOTA (Cx - TDI151)	135
5.9.3	IOTA board and connections - Digital Input High Voltage module	135
5.10	Digital Input 24V IOTA Models CC-TDIL01, CC-TDIL11	139
5.10.1	Field wiring and module protection - Digital Input 24V module (CC-TDIL01, CC-TDIL11)	139
5.10.2	Using DI 24V module (CC-TDIL01, CC-TDIL11) channels to report system alarms	143
5.10.3	Connecting the Power System alarm cable for RAM Charger Assembly 51199932-200	144
5.11	Digital Input 24V IOTA Models Cx - TDIL51, Cx - TDIL61	147
5.11.1	Field wiring and module protection - Digital Input 24V module (Cx - TDIL51, Cx - TDIL61) ..	147
5.11.2	Using DI 24V module (Cx - TDIL51, Cx - TDIL61) channels to report system alarms	150
5.12	Digital Output 24V IOTA Models CC-TDOB01, CC-TDOB11	153
5.12.1	Field wiring and module protection - Digital Output 24V module (CC-TDOB01, CC-TDOB11)	153
5.12.2	IOTA board and connections - Digital Output 24V module (CC-TDOB01, CC-TDOB11)	153
5.13	Digital Output 24V IOTA Models Cx-TDOD51, Cx-TDOD61	158
5.13.1	Field wiring and module protection - Digital Output 24V (Cx-TDOD51, Cx-TDOD61)	158
5.13.2	IOTA board and connections - Digital Output 24V (Cx-TDOD51, Cx-TDOD61)	158
5.14	Digital Output Relay Module IOTA Models CC-TDOR01, CC-TDOR11	163
5.15	Digital Output Relay Extender board Models CC-SDOR01	165
5.15.1	DO Relay cover	167
5.15.2	To mount the DO Relay cover	167
5.16	Speed Protection Module IOTA Model CC-TSP411	169
5.16.1	SPM Input wiring	171
5.17	Servo Valve Positioner Module IOTA Models CC-TSV211	176
5.17.1	SVPM Input wiring	178
5.18	Universal Input/Output IOTA Models CC-TUIO01 and CC-TUIO11	184
5.18.1	UIO channel configured as Analog Input	186
5.18.2	Allowable field wiring resistance - UIO - Analog Input channel	189
5.18.3	UIO channel configured as Analog Output	189
5.18.4	UIO channel configured as Digital Input	190
5.18.5	UIO channel configured as Digital Output	191
5.18.6	DO channel wiring configuration for ganging	192
5.19	Universal Input/Output Phase 2 IOTA Models CC-TUIO31 and CC-TUIO41	194
5.19.1	UIO-2 channel configured as Analog Input	196
5.19.2	Allowable field wiring resistance - UIO-2 - Analog Input channel	199
5.19.3	UIO-2 channel configured as Analog Output	199
5.19.4	UIO-2 channel configured as Digital Input	200
5.19.5	UIO-2 channel configured as Digital Output	201

5.19.6 DO channel wiring configuration for ganging	202
5.20 Low Level Analog Input (LLAI) Module IOTA model CC-TAIL51	204
5.20.1 Field wiring for thermocouple/RTD	206
5.21 Pulse Input Module IOTA Model CC-TPIX11	207
5.22 Upgrading Firmware in Series C I/O components	209
6 Series C PIM connectivity	211
6.1 PIM connectivity block diagram	212
6.2 Field device output stage types	214
6.3 PIM resistor bias terminal blocks	215
6.3.1 Inserting and removing resistors	215
6.4 TB1 signal definitions	217
6.5 TB1 pin assignments	218
6.6 TB2 pin assignments for internal/external field sensor power	219
6.6.1 Restrictions/limitations while using TB2	219
6.6.2 Verifying the connection	220
6.6.3 Examples to illustrate sensor power connections through TB2	221
6.7 TB3 pin assignment for fast cutoff relays	224
6.7.1 Key points on relays	224
6.8 About enabling pulse proving in PIM	226
6.9 TB4 pin assignment for Prover Pulse Bus	228
6.10 Using Prover Pulse Bus with optocoupler	229
6.11 Connecting PIM with ST500 dual-pulse simulator (Swinton Technology)	232
6.11.1 Differential manner	232
6.11.2 Single-ended manner	233
6.12 Connecting PIM with dual stream devices	234
6.13 Connecting PIM with other sensor types	235
6.14 Selecting PIM input threshold	237
6.15 Recommended cable types	238
6.15.1 Tips on cable usage	238
7 Series C Universal Horizontal Input/Output (UHIO) components	239
7.1 About the Horizontal C300/CF9 IOTA	241
7.2 About the Horizontal UHIO IOTA	242
7.2.1 Mapping the UIO channels to specific I/O types	243
7.2.2 Spare point I/O configuration	245
7.2.3 Guidelines for using the HART devices with the AO channel	248
7.2.4 UHIO Specifications	249
7.3 About the I/O connectors	250
7.4 Components of UHIO	252
7.4.1 Horizontal Backplane	252
7.4.2 Battery mounting panel and RAM Battery Backup	253
7.4.3 UHIO Power Supply	256
7.4.4 Half panel plastic cover	257
7.4.5 UHIO cables	259
7.4.6 UHIO Hardware Model Numbers	261
7.4.7 Mounting Assembly CC-ZHMT10	270
7.5 Mounting the UHIO components	273
7.6 General regulatory compliance	274
7.7 COTS AC-DC Power supplies	275
7.8 Protective Earth (Safety Ground)	276
7.9 Environmental Characteristics	278
8 Rail-Mounted Universal Input/Output (UIO) Module	279
8.1 Physical description of rail-mounted UIO module assembly	280
8.2 Input/output Link (IOL) management	282

8.3	Single Mode FOE for rail-mounted UIO	283
8.4	System wiring	284
8.5	Power supply requirements	286
8.5.1	Fused Terminal Block	287
8.5.2	Circuit Breaker	287
8.6	Agency approvals	288
8.7	Environmental Conditions	289
8.8	Rail-mounted UIO module assembly	290
8.8.1	Assembling the base tray	290
8.9	Mounting base tray assembly on DIN rail	294
8.10	Mounting UIO module on the IOTA	297
8.11	Grounding and power connections	299
8.12	Wiring connections	301
8.12.1	Conncting wires and cables	301
8.13	Removing rail-mounted UIO module	307
8.14	Replaceable spare parts	308
9	Series C I/O Configuration Form Reference	309
9.1	Determining Series C I/O block redundancy	310
9.2	Switchover and Secondary readiness	311
9.3	Failure conditions and switchover	312
9.4	Configuration tools to create control strategies	313
9.5	Configuring the Main tab - IOM block	314
9.6	Configuring Server History tab - IOM block	317
9.7	Configuring Server Displays tab - IOM block	320
9.8	Configuring Control Confirmation tab - IOM block	323
9.9	Configuring Identification tab - IOM block	325
9.10	Configuring QVCS tab - IOM block	327
9.11	Configuring the Calibration tab - IOM block	329
9.12	Configuring HART Status tab - IOM block	331
9.13	Configuring the Configuration tab - Channel block	332
9.14	Configuring the Configuration tab - PI channel block	333
9.15	Configuring Channel Configuration tab - UIO/UIO-2 module block	335
9.16	UIO/UIO-2 DI channel block configuration	337
9.16.1	Configuring the DI channel for pulse counting	337
9.17	Configuring the Configuration tab - UIO/UIO-2 DO channel block	339
9.17.1	Configuring the DO channel for ganging	339
9.18	Configuring HART Configuration tab - Channel block	341
9.19	Configuring HART Device Status tab - Channel block	343
9.20	Configuring HART Identification tab - Channel block	344
9.21	Configuring HART Variables tab - Channel block	346
9.22	Configuring HART Notifications tab - Channel block	348
9.23	Configuring Dependencies tab - Channel block	349
9.24	Configuring Template Defining tab - Channel block	350
10	Series C I/O Configuration	351
10.1	Adding an IOM to Project	352
10.1.1	Using the File menu method	352
10.1.2	Using the drag and drop method	353
10.2	Assigning an IOM to an IOLINK	355
10.3	Converting the Spares to specific channel type	356
10.4	Assigning the channel to IOM by instantiation	358
10.5	Assigning the channel to IOM through Bulk Edit	359
10.6	Adding an IOC block to a Control Module using the Library tab	360
10.7	Assigning an IOC block to an IOM using the Function Block Assignment Dialog box	361

10.7.1	Identification of unused I/O channels	362
10.7.2	Identification of ganged DO channels	364
10.8	Unassigning an IOC block from an IOM using the Function Block Assignment Dialog box	367
10.9	Configuring I/O channels in a control strategy using IOREFERENCES blocks	368
10.9.1	IOREFERENCES blocks for I/O channels	368
10.9.2	Associating the channel to IOREFERENCES block	368
10.10	Field Calibration of the AI and AO modules	370
10.11	Defining Channel blocks	371
10.11.1	Common features of I/O channel blocks	371
10.11.2	Defining Mode and Attribute settings	371
10.11.3	Defining load attributes	372
10.11.4	Defining Fault State Handling and Fault Option settings	372
10.11.5	FAULTED state and IOM hard failure	374
10.11.6	Defining PV Source selection settings	375
10.11.7	Defining the REDTAG settings	376
10.11.8	Enabling HART in HART 6.0 and later version devices	376
10.11.9	Features and capabilities - HART 6.0 and later version devices	376
10.11.10	Parameters exposed after HART is enabled	378
10.11.11	Comparing parameters between Series C and PMIO	379
10.11.12	Parameter values not copied during Block Copy	379
10.12	Defining AI Channel Blocks	380
10.12.1	Determining PV Characterization - AI Channel blocks	381
10.12.2	Determining Linear Conversion - AI Channel blocks	382
10.12.3	Determining Square Root Conversion - AI Channel blocks	383
10.12.4	Determining Thermal Conversion - AI Channel blocks	384
10.12.5	Open Wire Detection - AI Channel blocks	385
10.12.6	Checking and Filtering PV Range - AI Channel blocks	385
10.12.7	Comparing parameters between Series C and PMIO that support AI	385
10.13	Defining AO Channel Blocks	387
10.13.1	Determining Direct/Reverse Output - AO Channel blocks	387
10.13.2	Determining Output Characterization - AO Channel blocks	388
10.13.3	Determining Calibration Compensation - AO Channel blocks	388
10.13.4	Determining Modes - AO Channel blocks	389
10.13.5	Determining Output Verification - AO Channel blocks	389
10.13.6	Comparing parameters between Series C and PMIO that support AO	389
10.14	Defining DI Channel Blocks	390
10.14.1	Determining Status Digital Input channel - DI Channel blocks	390
10.14.2	Determining Latched Digital Input channel - DI Channel blocks	391
10.14.3	Comparing parameters between Series C and PMIO that support DI	391
10.14.4	Open Wire Detection - DI Channel blocks	391
10.15	Defining DO Channel Blocks	393
10.15.1	Determining Status Output type - DO Channel blocks	394
10.15.2	Determining Pulse Width Modulated (PWM) Output type	394
10.15.3	Determining On-Pulse and Off-Pulse Output type - DO Channel blocks	394
10.15.4	Determining Initialization Request Flag - DO Channel blocks	395
10.15.5	Determining Modes - DO Channel blocks	396
10.15.6	Determining Output Verification - DO Channel blocks	396
10.15.7	Determining Over-current protection - DO Channel blocks	396
10.15.8	Comparing parameters between Series C and PMIO that support DO	396
10.16	Electronic Short-Circuit Protection (DO-24V only)	398
10.16.1	Non-redundant Configuration	398
10.16.2	Redundant Configuration	398
10.16.3	Electronic Short-Circuit Fault Recovery	399
10.16.4	To clear the short-circuit fault:	399

10.17	Defining SP-AI Channel Blocks	400
10.17.1	Determining PV Characterization - SP-AI Channel blocks	400
10.17.2	Determining Linear Conversion - SP-AI Channel blocks	401
10.17.3	Determining Square Root Conversion - SP-AI Channel blocks	402
10.17.4	Open Wire Detection - SP-AI Channel blocks	402
10.17.5	Checking and Filtering PV Range - SP-AI Channel blocks	403
10.18	Defining SP-AO Channel Blocks	404
10.18.1	Determining Direct/Reverse Output - SP-AO Channel blocks	405
10.18.2	Determining Output Characterization - SP-AO Channel blocks	405
10.18.3	Determining Calibration Compensation - SP-AO Channel blocks	406
10.18.4	Determining Modes - SP-AO Channel blocks	406
10.18.5	Determining Output Verification - SP-AO Channel blocks	406
10.19	Defining SP-DI Channel Blocks	407
10.19.1	Determining Status Digital Input Channel - SP-DI Channel blocks	407
10.19.2	Determining Latched Digital Input Channel - SP-DI Channel blocks	408
10.19.3	Open Wire Detection - SP-DI Channel blocks	408
10.20	Defining SP-DO Channel Blocks	409
10.20.1	Determining Status Output type - SP-DO Channel blocks	410
10.20.2	Determining On - Pulse Output type - SP-DO Channel blocks	410
10.20.3	Determining Initialization Request Flag - SP-DO Channel blocks	412
10.20.4	Determining Modes - SP-DO Channel blocks	412
10.20.5	Fail-safe configuration - SP-DO Channel blocks	412
10.21	Defining SP-SPEED Channel Blocks	413
10.21.1	PV computation for speed measurement	413
10.21.2	Configuring the SP_SPEED channel to measure speed	414
10.21.3	Determining PV Source Selection - SP-SPEED Channel blocks	414
10.21.4	Detecting Speed Input Failure	415
10.21.5	Detecting Reverse Rotation	415
10.21.6	Measuring flow in the turbine flow meters	415
10.21.7	Configuring the SP_SPEED channel to measure the flow	415
10.22	Defining SP-SPDVOTE Channel Blocks	417
10.22.1	Voting Logic Algorithm Execution	417
10.23	Defining SVP-AI Channel block	419
10.23.1	Determining PV Characterization if SENSRTYP is configured as 'LVDT' or 'RVDT' or 'Resolver'	419
10.23.2	Determining PV Source Selection - SVP-AI Channel blocks	421
10.23.3	Determining Linear Conversion - SVP-AI Channel blocks	421
10.23.4	Determining PV Characterization if SENSRTYP is configured other than 'LVDT' or 'RVDT' or Resolver	422
10.23.5	Determining Square Root Conversion - SVP-AI Channel blocks	422
10.23.6	Detecting Open Wire - SVP-AI Channel blocks	423
10.23.7	Checking and Filtering PV Range - SVP-AI Channel blocks	423
10.23.8	Configuring the SVP_AI channel for angular measurement using Resolver	423
10.23.9	Configuring angle offset value	424
10.24	Defining SVP-DI Channel Block	425
10.24.1	Determining Status Digital Input Channel - SVP-DI Channel blocks	425
10.24.2	Determining Latched Digital Input Channel - SVP-DI Channel blocks	426
10.24.3	Low Latency Mode - SVP-DI Channel blocks	426
10.24.4	Open Wire Detection - SVP-DI Channel blocks	426
10.25	Defining SVP-Regulatory Control Block	427
10.25.1	PV and SP Processing	427
10.25.2	PV handling when PVSTS is BAD	428
10.25.3	Set Point (SP) Limit checking	428
10.25.4	Determining and handling modes	429
10.25.5	Initial Control Processing	429

10.25.6	Control Initialization	430
10.25.7	Algorithms	430
10.25.8	Output biasing process	430
10.25.9	Time-out monitoring	431
10.25.10	Time-out processing	431
10.25.11	Anti-reset windup status	431
10.25.12	Mode shedding on timeout	432
10.25.13	Output Processing	432
10.25.14	Bad Control Processing	432
10.25.15	Output Limiting	433
10.25.16	Windup processing and handling	433
10.26	Defining SVP-AO Channel Block	435
10.26.1	Determining Output Characterization - SVP-AO Channel block	435
10.26.2	Determining Direct/Reverse Output - SVP-AO Channel block	437
10.26.3	Determining Modes - SVP-AO Channel block	438
10.27	Defining UIO Channel Blocks	439
10.27.1	Example configuration for DO channel ganging	439
10.27.2	Example configuration for pulse counting functionality	440
11	Series C I/O Loading	441
11.1	Loading an IOLINK	442
11.1.1	Upload error conditions	442
11.2	Loading the IOM block the first time	443
11.2.1	Loading with the IOM block missing on the IOLINK	444
11.2.2	Reloading the IOM block from Project or Monitoring	444
11.2.3	Reviewing IOM re-configuration rules	445
11.3	Loading the individual I/O channels	447
11.4	Behavior of IOMs and CMs under version control	448
11.5	Common I/O block load activities	449
11.5.1	Uploading the I/O block	449
11.5.2	Update to Project	449
11.5.3	Reviewing the Update function	449
11.5.4	Using IOM Checkpoint	449
11.6	Loading a Control Module	450
11.6.1	Upload error conditions	451
11.6.2	Reloading the CM from Project or Monitoring	451
11.7	Setting Priority IOMs	452
11.7.1	To set the Priority IOM	452
12	Series C I/O Operations	455
12.1	Reviewing the Series C I/O block icons in Control Builder	456
12.2	Reviewing the IOLINK block icons in Control Builder	457
12.3	Reviewing the block icons in Control Builder	458
12.4	Reviewing the channel icons in Control Builder	459
12.5	Series C I/O LED Descriptions	460
12.6	Powering up the IOM	462
12.7	Activating a control strategy from the Monitoring tab	463
12.7.1	Starting an IOM	463
12.7.2	Issuing Shutdown command	463
12.8	Activating HART	465
12.8.1	Assigning a channel to HART - Series C	465
12.8.2	Enabling HART Alarm and Events - Series C	465
12.8.3	Disabling HART Alarm and Events	465
12.8.4	Migrating HART IO modules to/from non-HART IO modules	466
12.8.5	Migrating between different Model Numbers of Modules without HART	466

12.9 IOM configuration values not copied during Block Copy operation	468
12.10 SOE Scenarios	469
12.10.1 Input chatter scenario	469
12.10.2 PVCHGDLY scenarios	470
12.10.3 PV State Change event Regeneration	470
12.11 SOE Events configuration	471
12.11.1 SOE Events	471
12.12 DIMODE and OWDENBL related scenarios	472
12.12.1 Low Latency Mode	473
12.12.2 OWDENBL changes in Project View	473
12.13 Enabling pulse proving in Pulse Input Module	474
12.14 Enabling Fast Cutoff mechanism in PI channel block	476
12.15 Monitoring I/O modules	478
12.15.1 Main tab - DI channel block	478
12.15.2 AI Status Data tab	478
12.15.3 AO Status Data tab	479
12.15.4 DI Status Data tab	480
12.15.5 DO Status Data tab	481
12.15.6 Status Data tab	482
12.15.7 PIM Status Data tab	483
12.15.8 Maintenance tab	484
12.15.9 UIO Maintenance tab	485
12.15.10 UIO – 2 Maintenance tab	486
12.15.11 Box Soft Failures tab	487
12.15.12 Channel Soft Failures tab	488
12.15.13 HART Device Status tab - Channel block	489
12.15.14 HART Identification tab - Channel block	490
12.15.15 HART Variables tab - Channel block	492
12.16 Calibrating the DC output voltage for a Meanwell redundant system	495
12.17 Calibrating the DC output voltage for a non-redundant Meanwell system	496
12.18 Calibrating the DC output voltage for a Phoenix redundant power system	497
12.19 Power up the COTS power system	500
13 Series C I/O Link Fiber Optic Extenders (FOE)	501
13.1 Overview of multi-mode FOE	502
13.1.1 Fiber Optic Extender assembly	502
13.1.2 FOE features	503
13.1.3 Fiber Optic redundancy	504
13.1.4 FOE assembly certification details	504
13.2 FOE Installation	505
13.2.1 Handling components - ESD	505
13.2.2 Work practices	505
13.2.3 Hazardous areas	505
13.2.4 Operations	505
13.2.5 Checking and Maintenance	505
13.2.6 Installation	505
13.3 Component mounting sequence	507
13.3.1 Mounting the FOE module onto the IOTA	507
13.3.2 Connecting the FOE module's power cable to the module	507
13.3.3 Removing the FOE IOTA F1 fuse	507
13.3.4 Mounting the FOE module/IOTA assembly to the carrier	508
13.3.5 Connecting the IOLINK interface cable to the FOE module	508
13.3.6 Re-installing the FOE IOTA F1 fuse	509
13.3.7 Connecting the fiber optic cables to the FOE module	509
13.3.8 FOE connection rules	510

13.3.9	LED indicators	510
13.4	Defining the Fiber Optic topology	511
13.4.1	FOE capacity	511
13.4.2	Required hardware	511
13.4.3	Fiber Optic Extender interface cable	512
13.4.4	Fiber optic cable - length factors	512
13.4.5	FOE topologies - Daisy chain topology	512
13.4.6	FOE topologies - Star topology	512
13.4.7	Maximum flight delay times	513
13.4.8	Fiber optic budget considerations	513
13.4.9	Standard I/O link extender maximum cable span calculation	513
13.4.10	Available standard I/O link extender optical power	513
13.4.11	Losses in splices	514
13.4.12	Honeywell ST-type connector cable assemblies	514
13.4.13	Link A and B cable length differences	514
13.4.14	Allowable standard I/O Link extender cable signal loss	514
13.5	Single mode fiber optic extender	515
13.5.1	Key features of single mode FOE	515
13.5.2	Key features of single mode converter	516
13.5.3	Single mode FOE installation	517
13.5.4	Mounting the single mode FOE on the DIN rail	517
13.5.5	Single mode FOE IOLINK interface cable details	518
13.5.6	Single mode FOE IOLINK connection	518
13.5.7	FOE fiber connections	520
13.5.8	Power connection details for the single mode FOE on IOTA	520
13.5.9	Connecting the power cables to the single mode FOE on DIN rail	521
13.5.10	Using Meanwell/Phoenix Contact power supply	521
13.5.11	Using TDI power supply	522
13.5.12	Replacing the FOE fuse on the terminal block when FOE is mounted on DIN rail	523
13.5.13	Removing the FOE module from the DIN rail	523
13.5.14	Single mode FOE configuration	523
13.5.15	Pull High/Low resistor setting	523
13.5.16	DIP switch settings	524
13.6	Defining the single mode fiber optic topology	526
13.6.1	FOE capacity	526
13.6.2	Required hardware	526
13.6.3	Fiber Optic Extender interface cable	526
13.6.4	Fiber optic cable - length factors	527
13.6.5	Standard I/O link extender maximum cable span calculation	527
13.6.6	Available standard I/O link extender optical power	527
13.6.7	Losses in splices	527
13.6.8	Link A and B cable length differences	528
13.6.9	Allowable standard I/O Link extender cable signal loss	528
14	Series C Migrating from PMIO to Series C I/O	529
14.1	Determining Series C I/O vs. PMIO functionality	530
14.2	Migrating channels blocks from PMIO to Series C I/O	532
15	Series C I/O Troubleshooting	535
15.1	Self-test diagnostics at power-up	536
15.2	IOLINK - loss of communication problems	537
15.3	IOLINK - re-establishing communications	538
15.4	FOE Troubleshooting	539
15.4.1	Loss of power	539
15.4.2	Loss of communication	540

16 Series C I/O Maintenance	541
16.1 Series C recommended spares	542
16.1.1 IOM removal and installation under power	542
16.2 Replacing a Series C IOTA	549
16.3 Replacing an I/O module	550
16.4 FOE recommended spares	551
16.5 FOE Maintenance	552
16.5.1 Replacing the FOE IOTA F1 fuse	552
16.5.2 Replacing the FOE fuse on the terminal block when FOE is mounted on DIN rail	552
16.5.3 Replacing the FOE module on the IOTA	552
16.5.4 Removing the FOE module from the DIN rail	553
16.5.5 Removing the FOE assembly from the carrier	553
16.5.6 Hazardous Area Cable Requirements	554
16.5.7 Cable jacket Building Code Requirements	554
16.5.8 Cable temperature variation considerations	554
16.5.9 Spare fiber cable recommendation	555
17 Series C Power Sub-System Connections and Alarm Indications	557
17.1 Series C DC Power Connections and Indicators	558
17.1.1 Terminal block connections - Meanwell power system	563
17.1.2 Terminal block connections - Phoenix power system	564
17.2 Series C Power Sub-System LED Indications	566
17.2.1 Series C Power Sub-System LED indications - Meanwell power system	567
17.2.2 Series C Power Sub-System LED indications - Phoenix power system	567
17.3 Series C Power Sub-System Alarm Contacts and LED Activation Levels	568
18 Series C I/O Alarms and Failures	569
18.1 Reviewing IOM alarms generated by the C300	570
18.1.1 HART alarms/events	570
18.1.2 Field device status notifications	570
18.1.3 HALARMENABLE	570
18.2 Reviewing IOM soft failures	571
18.2.1 01 STCOVRUN	571
18.2.2 02 REQOFLOW	571
18.2.3 06 FTAMISSG	571
18.2.4 07 EECKSMER	572
18.2.5 08 EECNTERR	572
18.2.6 09 EEFLAGER	572
18.2.7 21 INPTFAIL	573
18.2.8 23 OUTPUTFL	573
18.2.9 24 STCKLIM	573
18.2.10 26 DIAGCTFL	573
18.2.11 31 FTAMSMCH	574
18.2.12 32 VZERO-FL	574
18.2.13 33 BADRJVAL	574
18.2.14 36 FTA1FAIL	574
18.2.15 37 FTA2FAIL	575
18.2.16 38 CALBABRT	575
18.2.17 39 BADCALRF	575
18.2.18 41 VREFFAIL	576
18.2.19 42 ADOUTUDF	576
18.2.20 43 ADOUTCAL	576
18.2.21 44 BADFLREG	576
18.2.22 45 BDSNDLTC	577
18.2.23 46 BDOUTBFR	577

18.2.24	47 VCALFAIL	577
18.2.25	48 F1NOTCAL	577
18.2.26	49 F2NOTCAL	577
18.2.27	50 F1COM_FL	578
18.2.28	51 F2COM_FL	578
18.2.29	52 F1_IDERR	578
18.2.30	53 F2_IDERR	579
18.2.31	54 F1VREFFL	579
18.2.32	55 F2VREFFL	579
18.2.33	56 F1CAL_FL	579
18.2.34	57 F2CAL_FL	580
18.2.35	58 LOSTSYNC	580
18.2.36	59 WRITENBL	580
18.2.37	60 MLTINPFL	580
18.2.38	61 REDNDIAG	581
18.2.39	63 WRONG_HW	581
18.2.40	64 HWFIFOFL	581
18.2.41	65 PRVRAMFL	581
18.2.42	66 SOECLKFL	582
18.2.43	67 PVVALDFL	582
18.2.44	68 SOECNTFL	582
18.2.45	69 DTPATHFL	582
18.2.46	70 DTPATHTO	582
18.2.47	71 STMACHFL	583
18.2.48	72 PIFAULTY	583
18.2.49	161 HMODEM1	583
18.2.50	162 HMODEM2	583
18.2.51	163 HMODEM3	584
18.2.52	164 HMODEM4	584
18.2.53	165 HDIAGTO	584
18.2.54	166 HSTACKHI	584
18.2.55	167 FTA3FAIL	585
18.2.56	168 FTA4FAIL	585
18.2.57	169 F3NOTCAL	585
18.2.58	170 F4NOTCAL	585
18.2.59	171 F3COMFL	586
18.2.60	172 F4COMFL	586
18.2.61	173 F3IDERR	586
18.2.62	174 F4IDERR	587
18.2.63	175 F3VREFFL	587
18.2.64	176 F4VREFFL	587
18.2.65	177 F3CALFL	587
18.2.66	178 F4CALFL	588
18.2.67	179 OPENWIRE	588
18.2.68	180 DOVRCRNT	588
18.2.69	181 FTAPOWFL	588
18.2.70	182 DPADIAFAIL	589
18.2.71	183 RDBKRGDIAGFL	589
18.2.72	184 WTDIAGFAIL	589
18.2.73	185 RLYEXTBDMSSNG	590
18.2.74	186 REDHWFAIL	590
18.2.75	187 HARTCHANFAIL	590
18.3	IOM hard failures	591
18.4	IOM Behavior during Hard Failures	592

18.5	Getting further assistance	593
18.5.1	Guidelines for requesting support	594
19	Series C I/O Galvanically Isolated / Intrinsically Safe Hardware	595
19.1	GI/IS IOTA models	596
19.1.1	Line-Fault Detection (LFD) - Digital Input GI/IS only	597
20	GI/IS Power and Grounding Requirements	599
20.1	Grounding and power considerations -GI/IS IOTA boards	600
20.1.1	Testing for power for GI/IS	600
20.1.2	Testing for power at the GI/IS IOTA screw	600
20.1.3	Testing for power at 24V bus bar top terminal for the GI/IS	600
21	GI/IS Installation	603
21.1	GI/IS Shield Connection Options	604
21.2	Installing the GI/IS IOTA onto the carrier	605
21.3	Installing the IOM onto the GI/IS IOTA	606
21.4	Installing the isolator	607
21.4.1	Precautions	607
21.4.2	Preparing the isolator for installation	608
21.4.3	Installing the isolator	608
21.5	Setting Operation mode through Digital Input isolator DIP switches	609
21.6	MTL4510	610
21.7	MTL4511 / 4516 / 4517	612
21.8	Field Wiring Connections	613
21.8.1	Isolator plug-in capability	613
21.8.2	Isolator removal	613
21.8.3	Screw-clamp terminals	613
21.9	Screw-terminal wiring	614
22	GI/IS IOTA Pinouts	615
22.1	GI/IS Analog Input IOTA Model CC-GAIX11	616
22.1.1	CC-GAIX11 Analog Input IOTA	616
22.1.2	CC-GAIX11 Analog Input IOTA connection diagram	617
22.2	GI/IS Analog Input IOTA Model CC-GAIX21	618
22.2.1	CC-GAIX21 Analog Input IOTA	618
22.2.2	CC-GAIX21 Analog Input IOTA connection diagram	618
22.2.3	Analog Input supported isolators	619
22.2.4	MTL4541 / 4544	620
22.2.5	MTL4575	620
22.2.6	Testing Temperature Converter- MTL4575	621
22.2.7	Default configuration	621
22.2.8	Configuration using PCS45/PCL45	621
22.2.9	Field Wiring Input Signals	622
22.2.10	Field Wiring Input Signals	622
22.3	Analog Output GI/IS IOTAs	623
22.4	GI/IS Analog Output IOTA Model CC-GAOX11	624
22.4.1	CC-GAOX11 Analog Output IOTA	624
22.4.2	CC-GAOX11 Analog Output IOTA connection diagram	625
22.5	GI/IS Analog Output IOTA Model CC-GAOX21	626
22.5.1	CC- GAOX21 Analog Output IOTA	626
22.5.2	CC-GAOX21 Analog Output IOTA connection diagram	626
22.5.3	Analog Output supported isolators	627
22.6	24 Vdc Digital Input GI/IS IOTAs	628
22.6.1	Input signal phase and IOTA features	628
22.7	GI/IS Digital Input IOTA Model CC-GDIL01	629

22.7.1	CC-GDIL01 Digital Input IOTA	629
22.7.2	CC-GDIL01 Digital Input IOTA connection diagram	630
22.8	GI/IS Digital Input IOTA Model CC-GDIL11	631
22.8.1	CC-GDIL11 Digital Input IOTA	632
22.8.2	CC-GDIL11 Digital Input IOTA connection diagram	633
22.9	GI/IS Digital Input IOTA Model CC-GDIL21	634
22.9.1	CC-GDIL21 Digital Input IOTA	634
22.9.2	Model CC-GDIL21 Digital Input IOTA connection diagram	634
22.9.3	Digital Input supported isolators (MTL4510 / 4511 / 4516 / 4517)	635
22.9.4	Digital Input isolator characteristics	635
22.10	GI/IS Digital Output IOTA Model CC-GDOL11	637
22.10.1	CC-GDOL11 Digital Output IOTA	637
22.10.2	CC-GDOL11 Digital Output IOTA	639
22.11	GI/IS Digital I/O Expander Model CC-SDXX01	641
23	PCS45 Configuration Software	643
23.1	PCS45 Operating Modes	645
23.1.1	Data format	645
23.1.2	Data flow	645
23.1.3	Temperature converter	645
23.1.4	PC-link - PCL45 and PCL45USB	646
23.1.5	Export and Print file	646
23.1.6	Damping and smoothing	647
23.1.7	Alarm signals	647
23.1.8	Trip output value	648
23.1.9	Menus	648
23.2	Troubleshooting the PSC45 software	654
23.2.1	Interface error	654
23.2.2	Configuration error	654
23.2.3	Device defective or causing problems error	654
23.2.4	Device exception status error	655
24	GI/IS Maintenance	657
24.1	GI/IS recommended spares	658
24.2	Repair	661
24.3	Replacing an GI/IS IOTA	662
24.4	Replacing an IOM on the GI/IS IOTA	664
24.5	Replacing the isolator	665
24.6	Replacing fuses on a GI/IS IOTA	666
25	GI/IS Troubleshooting	667
26	ATEX Information	669
26.1	General	670
26.1.1	Installation	670
26.1.2	Inspection and maintenance	670
26.1.3	Repair	670
26.1.4	Marking	670
26.2	Isolators safety parameters	672
27	Notices	673

1 About this guide

The procedures in this guide are intended to give you the ability to perform basic tasks with the Series C I/O such as configuring hardware devices, continuous control strategies. Respective forms are displayed to illustrate a procedure/concept only.

Revision History

Revision	Date	Description
A	November 2016	Initial release of the document.
B	May 2017	Updated the document regarding CC-TAID11 and CC-TAID01 IOTA pin numbers
C	July 2017	Updated PAR # 1-3OIYE85 and PAR # 1-45O69MG details in the document
D	August 2017	Updated Table 5: Topology rules regarding Series C IO module spec from 64 to 80 per C300 and Updated PAR # 1-TNZGOM details in the document
E	August 2017	Updated chapter 13 Series C I/O Link Fiber Optic Extenders (FOE) as per the received feedback.
F	December 2017	Updated PAR # 1-3NDHL6P details in the document.
G	February 2018	Updated PAR # 1-8Y24ZUX information in the document.

1.1 Intended audience

This guide is intended for the following users:

- Persons responsible for system planning, initial hardware installation, and control strategy configuration
- Operators who help to maintain control system operations on a day-by-day basis
- Service persons responsible for routine maintenance of control hardware, and who diagnose and repair faults.

1.2 Prerequisite Skills

It is assumed that you should have some knowledge of Experion control systems and experience of working in a Microsoft Windows environment.

1.3 References

Listed here are the documents that contain general information for planning and implementing control hardware and network communications in your Experion system:

- Control Hardware Planning Guide - Provides general information to assist you in planning and design of control hardware in an Experion system. Control hardware includes C200 Controllers, Series A Chassis I/O and FIMs, also, all I/O families, (except Series C I/O). It includes some supervisory network considerations for general reference.
- C300 Controller Guide - This guide provides information that will assist you in planning and designing activities, as well as the installation, operation, and troubleshooting of Series C300 Controllers in an Experion system.
- Series C Fieldbus Interface Module (FIM) User Guide - Provides planning and implementation guide for the Series C Fieldbus Interface Module.
- Fault Tolerant Ethernet Overview and Implementation Guide - Provides basic installation instructions and configuration requirements for a Fault Tolerant Ethernet (FTE) network and its components.
- Fault Tolerant Ethernet Installation and Service Guide - Contains instructions for installing and configuring a Fault Tolerant Ethernet (FTE) node. The guide includes troubleshooting and service information for an FTE node.
- Fault Tolerant Ethernet Bridge Implementation Guide - Provides information for implementing a Fault Tolerant Ethernet supervisory network through the FTE Bridge module. It includes module installation, configuration, operation and service data.
- Process Manager I/O Troubleshooting and Maintenance Guide - Guide features notification messages (soft fail codes and hard fail codes), service procedures and parts lists for PM I/O control hardware.

1.4 Terms and acronyms

The following table summarizes the terms and type representation conventions used in this guide.

Table 1: Terms and conventions

Term/conventions	Meaning	Example
Click	Click left mouse button once. (Assumes cursor is positioned on object or selection.)	Click the Browse button.
Double-click	Click left mouse button twice in quick succession. (Assumes cursor is positioned on object or selection.)	Double click the Station icon.
Drag	Press and hold left mouse button while dragging cursor to new screen location and then release the button. (Assumes cursor is positioned on object or selection to be moved.)	Drag the PID function block onto the Control Drawing.
Right-click	Click right mouse button once. (Assumes cursor is positioned on object or selection.)	Right-click the AND function block.
<F1>	Keys to be pressed are displayed in angle brackets.	Press <F1> to view the online Help.
<Ctrl>+<C>	Keys to be pressed together are displayed with a plus sign.	Press <Ctrl>+<C> to close the window.
File->New	Shows menu selection as menu name followed by menu selection	Click File->New to start new drawing.
>D:\setup.exe<	Data to be keyed in at prompt or in an entry field.	Key in this path location >D:\setup.exe<.

2 Series C I/O Purpose

Series C I/O Modules, along with I/O Termination Assemblies (IOTAs), perform module diagnostics input and output scanning and processing on all field I/O data and events. To allow a more efficient use of Controller resources, I/O processing is performed separately from control processing functions so that:

- I/O sample rates are completely independent of I/O quantity, controller loading, processing, and alarming
- allows more efficient use of advanced Control Processor capability, and
- provides for future I/O expansion.

Related topics

“Comparing Process Manager I/O and Series C I/O” on page 24

“What is Series C I/O?” on page 25

“Series C Pulse Input Module (SCPIM)” on page 26

“What is Universal Input/Output (UIO) Module?” on page 28

“What is Low Level Analog Input (LLAI) Module” on page 30

“Overview of the Universal Horizontal Input/Output (UHIO)” on page 31

2.1 Comparing Process Manager I/O and Series C I/O

The following list compares previous features of the Process Manager I/O and the Series C I/O:

- Non-Volatile Memory:
 - In the PM, memory was maintained over a power cycle within the I/O card itself.
 - With the Series C I/O, the configuration memory information is restored from the C300 controller at power-up of the I/O Module.
- IOL - The Series C I/O link runs at twice the speed of the PMIO I/O Link. Each C300 I/O Link can be configured to provide Series-C or PMIO link speeds.
- Series C I/O fully supports HART I/O. This includes the use of Secondary HART Variables as control parameters.
- Separation of Primary from Secondary modules:
 - In the PM, the Primary and Secondary I/O Electronics modules could be separated, placed in different cabinets, and/or powered by different power systems.
 - Series C I/O does not have this capability.
- Series C permits Zone 2 mounting of the Controller and I/O
- In PMIO, the configuration memory is maintained only if a battery backup is installed.

2.2 What is Series C I/O?

The Experion Series C I/O modules are an expanding family of traditional and special function input/output signal interface devices. They supports local software configuration. These I/O modules share the same form factor as the C300 Controller and reside on the same type of common mounting system as other Series C components.

What is Series C I/O Mark II?

Series C Mark II is an enhancement to the existing Series C platform in terms of IO modules, related IOTAs, IO link, power supply, power distribution, and cabinet infrastructure, making it a more cost-effective solution than the earlier version. The design style continues to be the same.

Supported Series C Mark II I/O modules



Attention

- Series C Mark II cannot support any PM I/Os.

C300 IOLINK block parameter IOLINKTYPE is used to determine if the IOLINK supports Series C Mark II I/O.

Table 2: Supported Series C Mark II I/O modules

IOM model names	IOM block name	Description	No. of channels supported
CC-PAIH01	AI-HART	High Level Analog Input with HART (4) IOM	16
CC-PAOH01	AO-HART	Analog Output with HART (4) IOM	16
DC-PDIL51	DI-24	Digital Input 24V IOM w/o OWD	32
DC-PDIS51	DI-SOE	Digital Input SOE IOM	32
DC-PDOD51	DO-24B	Digital Output 24V Bussed Out IOM w/o RB	32
DC-PDIS51	DI-SOE	Digital Input SOE IOM	32
CC-PAIM51	AI-LLAI	Low Level Analog Input Mux	16
CC-PAIH51	AI-HART	AI HART IOM , R2	16
CC-PAIN01	AI-NON-HRAT	AI IOM NON-HART	16
CC-PAOH51	AO HART	AO HART IOM, R2	16
CC-PAON01	AO-NON-HART	AO NON-HART IOM	16

2.3 Series C Pulse Input Module (SCPIM)

The Experion Series C PIM is an interface between C300 Controller that enables high-accuracy pulse counting of pulse streams from rotating machinery such as turbines, flow meters, and densitometers. High-accuracy and repeatable measurement capability make the PIM well suited for metering and custody transfer applications.

The PIM has eight input channels. Out of the eight channels, some may be single consuming one channel or dual consuming 2 adjacent channels. The last 2 channels (channel 7 and channel 8) can also be configured as distinct Fast Cutoff using the two output channels on the module.

Each input channel has a 32-bit counter to perform pulse counting and frequency calculation. In addition, when these channels are configured as single input channels, these eight channels also have a second 32-bit timer for pulse period and pulse width measurement.

2.3.1 Features of PIM

The following are some of key the features of PIM.

- Supports IOM redundancy.
- Supports redundant module communications with the controller via IO link.
- Supports simulation with SIM-C300 – The input value can be substituted by a program and/or UniSim using the SIMVALUE parameter.
- Supports high accuracy frequency, period, and pulse width measurement.
- Provides hardware support for Meter Suite applications.
- Provides connections to power field devices or pulse pre-amplifiers.
- Supports pulse multiplexing that enables good pulses from a dual pulse input pair to be copied to the Prover output interface.
- Supports Dual Pulse Integrity in accordance with ISO6551:1996 Level A, which is required to support interfacing of custody transfer meters with pulse outputs.
- Provides the flexibility of configuring the eight input channels as single input, dual input, or a combination of both single and dual input channels . For example you can configure the channels as;
 - 2 single input channels, 3 dual input channels or
 - 6 single input channels, 1 dual input channels.

For information on PIM specifications, refer to the Specifications document available on the Honeywell Online Support site.

2.3.2 Comparison between Series A and Series C PIM

The following table lists some of the differences between the Series A and Series C pulse input modules.

Series C PIM	Series A PIM
Shares the same form factor as the Series C I/O family.	Requires two form factors to use with C300 controller; series A for the Pulse Input and the series C form factor for the controller and other I/O modules.
Supports IOM redundancy.	Does not support IOM redundancy.
Supports Dual Pulse Integrity to support interfacing of custody transfer meters with pulse outputs.	Does not support Dual Pulse Integrity.
Supports pulse multiplexing that enables good pulses from a dual pulse input pair to be copied to the Prover output interface.	Does not support pulse multiplexing.

Series C PIM	Series A PIM
Supports pulse length measurement in all channels.	Does not support pulse length measurement in the last two channels.
Supports configuration of all eight channels through use of PICHANNEL block.	Needs two blocks for configuring channels: <ul style="list-style-type: none"> • Pulse Input Channel block for configuring the first six channels. • Pulse Input Channel with Fast Cutoff block for configuring the last two channels.
The last two channels can be configured as Pulse Input channel types or Pulse Input with Fast Cutoff channel types.	The last two channels can be configured only as Pulse Input with Fast Cutoff channel types.

2.4 What is Universal Input/Output (UIO) Module?

With R410, an Universal Input/Output (UIO) module is introduced that enables you to configure the input/output channels within a single IOM. The UIO module supports 32 channels. Each channel can independently be configured as one of the following types.

- Analog Input channel (0-20mA or 4-20mA)
- Analog Output channel (4-20mA)
- Digital Input channel (with or without broke-wire detection)
- Digital Output channel (with or without broke-wire detection)

The UIO channels and device blocks are compatible with existing Series C AI, AO, DI, and DO channels and blocks. In addition, each analog channel in the UIO module can be configured to support HART input/output functionality.

2.4.1 Features of UIO

The following list illustrates the key features of the UIO module.

- Supports optional IOM redundancy.
- Supports simulation with SIM-C300.
- Supports HART functionality for AI and AO channel types.
- Supports multiple channel type configurations.
- Operates in an extended temperature range (-40 degree Celsius to +70 degree Celsius).
- Supports the ability to monitor the current, minimum, and maximum temperatures.
- Supports remote control when it is located within 10 kilometers from the controller.
- Supports open wire detection.
- Supports DO channel ganging from R430 onwards.
- Supports pulse counting functionality from R430 onwards.

Note: To use an AI HART channel in conjunction with the analog mode, it must be used on channels 13 through 20 only. If HART is used on any of the voltage inputs, it can cause an unstable analog PV value. The HART digital value will be unaffected.

Note: For information about UIO specification, refer to the latest Specification and Technical document available on the Honeywell Online Support site.

2.4.2 UIO features

Support for DO channel ganging

The UIO-DO channel is now enhanced to support ganging for enabling the delivery of more current output to the field (maximum current output of up to 2.0 Amperes). This is accomplished using the existing UIO hardware. DO channel ganging simply requires software configuration of up to four adjacent DO channels of the UIO module and appropriate channel wiring accordingly.



Attention

- Up to four DO channels can be ganged at a time.
- UIO-channel 32 cannot be ganged with channel 1.

Support for pulse counting functionality

The UIO module DI channel is capable of providing pulse counting functionality. However, only four DI channels (channels 15, 16, 17 and 18) support pulse counting functionality.

The UIO-DI channel pulse counting supports counting up to 10 KHz of input pulse frequency.

The UIO DI channel configuration consists of simply setting the Digital Input Type parameter to “Accum” from the Configuration tab of the DI channel.



Attention

Though UIO supports redundancy, it does not support pulse count synchronization. Therefore, after a switchover the counters are reset and restart at 0. If pulse count synchronization is required, you must use the Series C Pulse Input Module.

2.4.3 Differences between UIO channels and existing Series C AI, AO, DI, and DO modules

The following table lists some of the differences between the UIO and the existing Series C AI, AO, DI, and DO modules.

UIO module	Series C AI, AO, DI, and DO modules
Supports temperature range between -40 degree Celsius to +70 degree Celsius	Supports temperature range between 0 degree Celsius to +50 degree Celsius
Supports multiple channel type configuration	Supports unique channel type configuration

2.5 What is Low Level Analog Input (LLAI) Module

Starting with R430, a new Series C compliant Low Level Analog Input (LLAI) Module is introduced and designed to operate with the low voltage devices such as Thermocouples and RTDs. The AI-LLAI module supports 16 channels and accepts temperature inputs in the range of millivolts (mV).

This AI-LLAI module is identical to the existing Series C AI-LLMUX module except that the number of channels supported by the AI-LLAI module is reduced to 16 channels. Unlike the AI-LLMUX module, the field inputs can be directly connected to the AI-LLAI IOTA since it has its own IOTA. In addition, the AI-LLAI module supports a new RTD input type, that is, CU50Rtd. A new library is introduced in the standard library as "AI-LLAI."

Features of AI-LLAI

The following are some of the key features of AI-LLAI.

- Supports up to 16 RTDs or Thermocouple inputs.
- Operates in an extended temperature range (-40 degree Celsius to +70 degree Celsius).
- Supports a new RTD input type, CU50Rtd.
- Supports configurable Open Thermocouple Detection (OTD).
- Supports 1 second PV scanning with OTD protection.
- Supports N type thermocouple.



Note

AI-LLAI module does not support the following features.

- Remote cold junction capability
 - User defined table
-

2.6 Overview of the Universal Horizontal Input/Output (UHIO)

The Universal Horizontal Input/Output (UHIO) enables the replacement of the TDC 2000 Basic Controllers (CB) and Extended Controllers (EC) with the Experion Series C controllers and Universal I/Os. To enable mounting in the existing cabinets, new IOTAs are designed for the C300 Controller, Control Firewall, and the Universal I/O module such that it can fit into the space of the CB and EC modules. However, the existing TCBxx terminal panel, and the field wiring to the TCBs are retained. Note that different IOTAs are required for the UIO and UIO-2 modules. Either IOTA will screw onto the back panel.

The introduction of the UHIO hardware allows customers to migrate their Hiway-based control system to the FTE-based Experion Series C control system.

The following figure is an example of CB/EC rack that is replaced with the Experion Series C controllers and Universal I/Os.

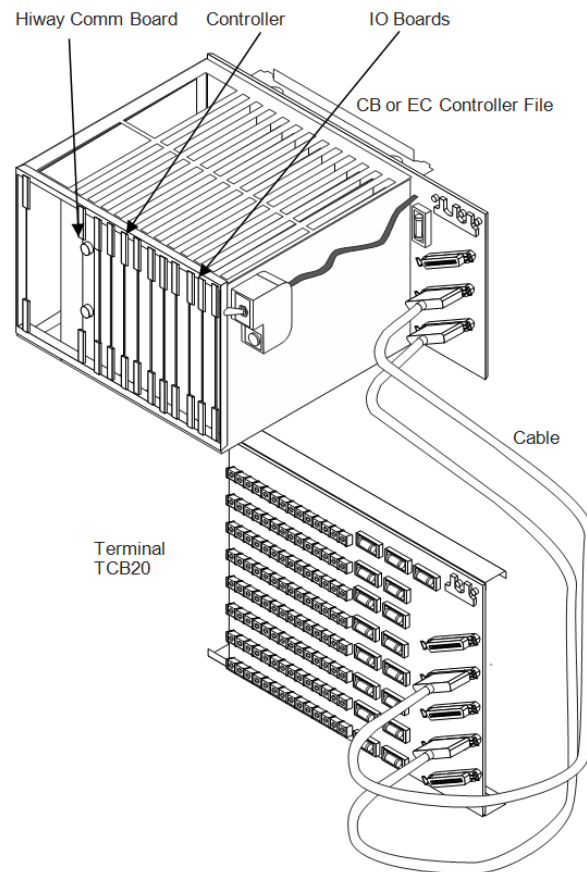

Figure 1: View of existing Basic Controller and Extended Controller

The following figures show the UHIO on the right side. The CC-HUIO11 uses UIO modules and the CC-HUIO12 uses UIO-2 modules.



Figure 2: Left: CC-HCN911 Right: CC-HUIO11



Figure 3: Left: CC-HCN911 Right: CC-HUIO12

In these figures, the following components are shown.

- Control Firewall
- C300 Controller
- Universal I/Os

2.6.1 Mapping the CB/EC racks with UHIO components

The following figure illustrates how to map the CB/EC with the UHIO components.

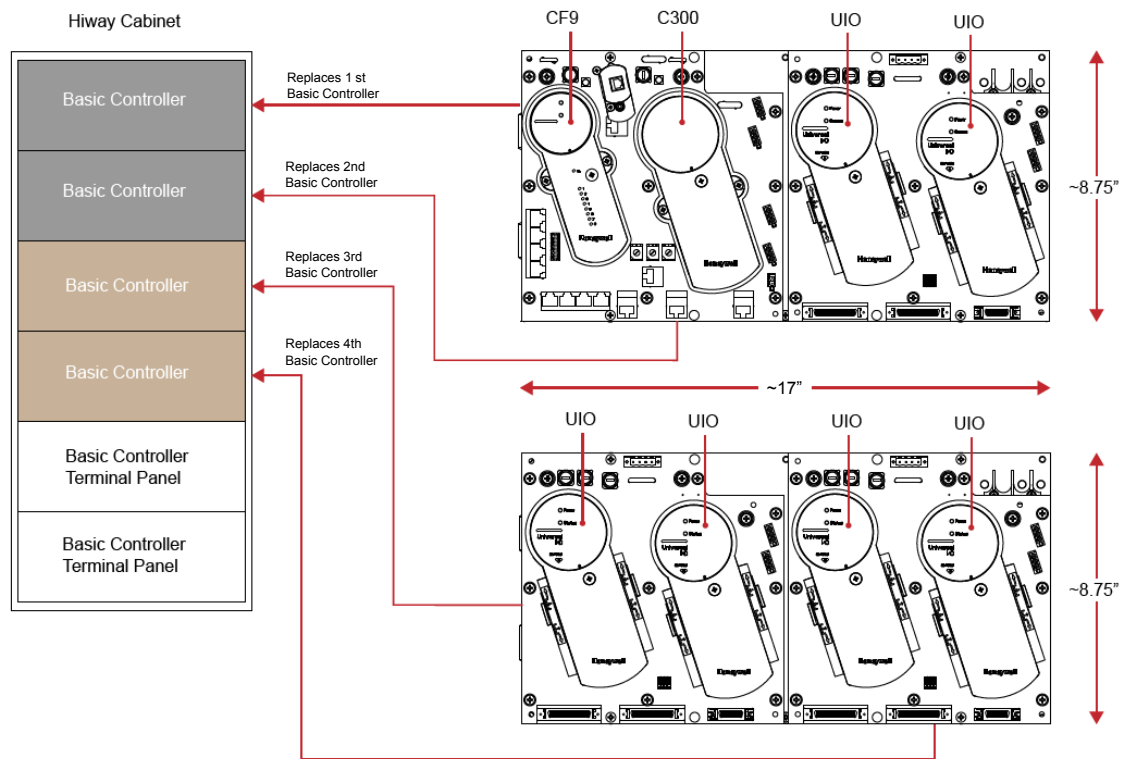

Figure 4: Mapping the CB/EC with the UHIO components

Attention

Note that you can increase the number of input/outputs by adding the Universal Input/Output (UIO) modules.

2.6.2 Features of UHIO

The key features of the UHIO are:

- Supports both redundant and non-redundant configuration for C300 Controller, UIO module, and CF9.
- Supports interchangeability of Series C components.
- Minimizes the effort for rewiring.

The UHIO also supports the following features.

- Provides mechanical connection to the TDC 2000 cabinet Backplane.
- Supports cabinet ground connections through the IOTA mounting screws.
- Provides electrical-mechanical connection to the IOM.
- Provides electrical-mechanical connection to the redundant IOL cable pair.
- Supports 24V fused electrical connections to the IOM(s) - Series C 24V and COM power supply.
- Supports a signal common ground.
- Supports precision resistors for measuring analog inputs.
- Supports connection for up to 24 IO channels on the existing TCBs.
- Supports connection for up to 8 additional IO channels at a location.
- Supports manual reset input(s) for restarting a stopped UIO module.

- Supports voltage or current inputs.
- Supports hot-insertion of C300, CF9, and UIO modules.

2.6.3 UHIO hardware

The UHIO uses the following Series C IO components.

- Plug-in modules such as C300, CF9, and UIO.
- FTE network communications between the controller and Experion Station.
- I/O Link between the controller and all I/O modules.
- Series C cabinet power supply.
- Experion Station and Control Builder as operator and engineering interfaces.



Attention

You cannot differentiate the appearance of the UHIO components from other Series C components in the Control Builder or the Station though the UHIO components are horizontally-oriented.

2.6.4 Differences between the Series C IOTA and the UHIO IOTA

The following table lists the differences between the Series C IOTA and the UHIO IOTA.

Table 3: Differences between the Series C IOTA and the UHIO IOTA

Series C IOTA	UHIO IOTA
C300, CF9, and the UIO IOTA is mounted on the Series C cabinet.	New IOTA developed for C300/CF9 IOTA and UHIO cannot be mounted on the Series C CCA's. It can be mounted in a TDC 2000 basic cabinet (not a Series C cabinet) or in a PMIO cabinet using a special mounting bracket.
Series C UIO IOTA does not interface UIO module to Basic Controller Terminal Panels (TCBxx). Instead, Series C UIO IOTA is designed to directly interface with the field sensors/actuators.	UHIO IOTA is designed to interface the UIO module to the Basic Controller Terminal Panels (TCBxx).
Series C IOTA is vertically mounted on the cabinet.	UHIO IOTA is horizontally mounted on the cabinet.



Attention

Series C Hazardous Certifications are not applicable to the UHIO components.

For more information about the C300/CF9/UHIO IOTA, see “Series C Universal Horizontal Input/Output (UHIO) components” on page 239.

2.6.5 About UHIO certification

General Purpose Certification

The UHIO's CSA General Purpose certification is applicable within Data Hiway (TDC 2000) cabinets with the Series C Power supply SPS5792-142935 (HPN 51454517-100). If any modifications have occurred since first installation, the UHIO's CSA General Purpose certification is voided and it is the responsibility of the end user to ensure they are still conforming to all applicable agency rules and regulations. The original TDC Basic Power Supplies do not support the UHIO CSA General Purpose Certification.

CE Mark certification

The UHIO's CE Mark is only applicable for installations within Data Hiway (TDC 2000) cabinets with the Series C Power supply SPS5792-142935 (HPN 51454517-100). It is assumed that the state of as shipped and as

first installed has been maintained for all applicable installations. For installations that do not satisfy the previously mentioned conditions, the end user is responsible to ensure that they conform to all applicable agency rules and regulations.

CC-HUIO12

The above constraints also apply to the CC-HUIO12 IOTA. Note that the CC-HUIO12 was tested with TCB cable 51192054 only. Using the original TCB cable 30731611 with adaptor cable 51202979 may not pass CE Mark tests. For the conducted immunity test between 150kHz and 250kHz, the AI accuracy was 4.3% instead of its normal 0.1% at room temperature.

3 Series C I/O Planning and Design

This guide is intended to provide general information to assist you in planning and designing the installation of your Experion Series C I/O.

Related topics

- “General Planning References” on page 38
- “Series C I/O and C300 topology” on page 42
- “Supported Series C I/O modules” on page 44
- “Supported Series C I/O options” on page 51
- “I/O Link performance specifications” on page 57
- “Universal Input/Output Module-2 (UIO-2)” on page 59

3.1 General Planning References

Refer to the following documents for planning and design details for the Experion system in general and the Fault Tolerant Ethernet supervisory network. For the sake of brevity, this Guide does not repeat the applicable general guidelines, considerations, and cautions that are covered in these other Guides.

- Control Hardware Planning Guide
- Server and Client Planning Guide
- Fault Tolerant Ethernet Overview and Implementation Guide



Tip

For complete Series C Control System Hardware Configuration planning information, refer to the Control Hardware Planning Guide.

3.1.1 Series C I/O appearance

The layout of Series C components supports enhanced heat management and provides a 30% reduction in overall size (space required to mount the hardware) versus the equivalent Process Manger set.

3.1.2 Series C I/O features

The features of Series C I/O include:

- IO Module design - tilted 18 degrees off center:
 - provides for better heat distribution
 - allows for efficient field wiring
- Combination of I/O Module and Field terminations in the same area. The I/O Module is mounted on the IOTA, which reduces cabinet space and eliminates items such as FTA connection cables.
- Redundancy is done directly on the IOTA by simply adding a second IOM to the IOTA (with the exception of the C300 controller).

For complete feature/functions for the following modules/IOTAs, refer to the Experion Series C I/O Specifications document.

Table 4: Series C features

I/O module/IOTA	Feature/function
Analog Input w/HART	<ul style="list-style-type: none"> • Extensive self-diagnostics • Optional redundancy • HART capable, multi-variable instruments • Fast (50ms) loop scan • PV protection through a broken-wire detection diagnostic <ul style="list-style-type: none"> – All channels configured for 4-20 mA inputs can detect broken field wires. A soft failure alerts the maintenance staff for corrective action. • Non-incendive field power <ul style="list-style-type: none"> – Non-incendive power for 4-20 mA loops is provided with no external marshalling.
Analog Input non-HART	<ul style="list-style-type: none"> • Extensive self-diagnostics • Optional redundancy • Fast (50ms) loop scan • Non-incendive field power

I/O module/IOTA	Feature/function
Analog Output w/HART	<ul style="list-style-type: none"> • Extensive self-diagnostics • Optional redundancy • HART capable, multivariable instruments • Safe-state (FAILOPT) behaviors <ul style="list-style-type: none"> – Each channel can be configured to HOLD, LAST, VALUE, or SHED to a SAFE VALUE. • Output read back checking of current delivered to the field • PV protection through a broken-wire detection diagnostic <ul style="list-style-type: none"> – Each channel can detect broken field wire. A soft failure alerts the maintenance staff for corrective action. • Non-incendive output <ul style="list-style-type: none"> – No external marshalling required to support the 4-20ma loop, and still provides for channel power protection.
Analog Output non-HART	<ul style="list-style-type: none"> • Extensive self-diagnostics • Optional redundancy • Safe-state (FAILOPT) behaviors <ul style="list-style-type: none"> – Each channel can be configured to HOLD, LAST, VALUE, or SHED to a SAFE VALUE. • Output read back checking of current delivered to the field • Non-incendive output
Digital Input 24VDC	<ul style="list-style-type: none"> • Extensive self-diagnostics • IOM redundancy • Input direct/reverse • Internal or external field power selections • Galvanic isolation • PV protection through a broken-wire detection diagnostic <ul style="list-style-type: none"> – Each channel can detect broken field wire. A soft failure alerts the maintenance staff for corrective action. • Non-incendive output <ul style="list-style-type: none"> – No external marshalling required to support the 4-20ma loop, and still provides for channel power protection.
Direct Input High Voltage	<ul style="list-style-type: none"> • Extensive self-diagnostics • Optional redundancy • Input direct/reverse • Galvanic isolation
Digital Input High Voltage PROX	<ul style="list-style-type: none"> • Extensive self-diagnostics • Input direct/reverse • Galvanic isolation

I/O module/IOTA	Feature/function
Direct Input - Sequence of Events DI-SOE	<ul style="list-style-type: none"> • Extensive self-diagnostics • Optional redundancy • 1ms Sequence of Events for Discrete Inputs • Low Latency / High Speed Scanning mode • Broken wire detection • Supplies non-incendive field power • On board excitation power (no need for marshalling power) • Direct / Reverse Input Indication Galvanic isolation
Direct Output bussed 24Vdc	<ul style="list-style-type: none"> • Extensive self-diagnostics • Functional redundancy • Output direct/reverse • Safe-state (FAILOPT) behaviors <ul style="list-style-type: none"> – Each channel can be configured to HOLD, LAST, VALUE, or SHED to a SAFE VALUE. • Fuse-less short circuit protection <p style="margin-left: 20px;">allows a short circuit to exist without blowing any fuses. When a particular channel is shorted, internal circuits detect this and remove power to the field connection. The channel remains de-energized until the short circuit is repaired</p> • Latched, pulsed or pulse-width modulated output • Galvanic isolation • Output read back checking to screw terminal
Digital Output - Relay IOTA	<ul style="list-style-type: none"> • Galvanic isolation • Counter EMF snubbing circuit • Isolated dry contact (Form A or B) • Output read back checking on system side of driver
Low Level Analog (temperature) Input - LLMUX	<ul style="list-style-type: none"> • TC and RTD operation • Remote cold junction capability • 1 Second PV scanning with OTD protection • Configurable OTD protection (See below) • Temperature points can be added in 16 point increments
Low Level Analog (temperature) Input - LLAI	<ul style="list-style-type: none"> • Thermocouple (TC) and RTD operation • 1 Second PV scanning with Open Thermocouple Detection (OTD) protection • Configurable OTD protection
Speed Protection Module - SP	<ul style="list-style-type: none"> • Supports 2/3 voting logic for speed and acceleration. • Supports multiple configurable trip limits for speed and acceleration.
Servo Valve Positioner Module - SVPM	<ul style="list-style-type: none"> • Supports PID execution and position calibration. • Computes valve position from LVDT/RVDT input signal and controls valve by signaling the Servo coil. • Provides current modulation to avoid stiction in controlled device (servo valve).
Pulse Input Module - PIM	<ul style="list-style-type: none"> • Highly accurate frequency/period calculations. • Supports Dual Pulse Integrity in accordance with ISO6551:1996 Level A for custody transfer applications. • Extensive self-diagnostics. • Functional redundancy. • Provides channel-to-channel and terminal block to backplane voltage isolation.

I/O module/IOTA	Feature/function
Universal Input/Output Module - UIOM	<ul style="list-style-type: none"> • Extensive self-diagnostics • Optional redundancy • Independently configurable I/O channels <ul style="list-style-type: none"> – controls DI, AI, DO, AO • HART capable, multivariable instruments • PV protection through a broken-wire detection diagnostic • Safe-state (FAILOPT) behaviors • Supports multiple channel configurations <p>UIO-2</p> <p>In addition to all features supported by UIO, the UIO-2 supports the following additional features:</p> <ul style="list-style-type: none"> • Provides one HART modem per I/O channel • Supports pulse counting on up to four of any of the 32 channels configured as DI • Supports DO ganging within the following eight channel number groups: 1 - 4, 5 - 8, 9 - 12, 13 - 16, 17 - 20, 21 - 24, 25 - 28, and 29 – 32. However, ganging across these groups is NOT possible <p>Beginning with Experion R500.1, the following new features are available:</p> <ul style="list-style-type: none"> • Supports SOE on any channel • Supports NAMUR inputs. This function, however, will require external voltage translation for devices that do not support direct connection 24 VDC

3.2 Series C I/O and C300 topology

Attention

Topology for the Series C I/O and C300 - 20mS CEE Controller is similar to the Series C I/O and C300 - 50ms Controller, with the exception that the C300 - 20mS CEE Controller does not support the PMI/Os.

Series C I/O is attached to an IOLINK that is being mastered by a C300 controller. It is important to note that:

- IOLINK - Serves as data repository for IOM function blocks in Control Builder to provide communications interface with Series C I/O.
- Series C I/O cannot reside on an IOLINK mastered by an IOLIM or xPM.

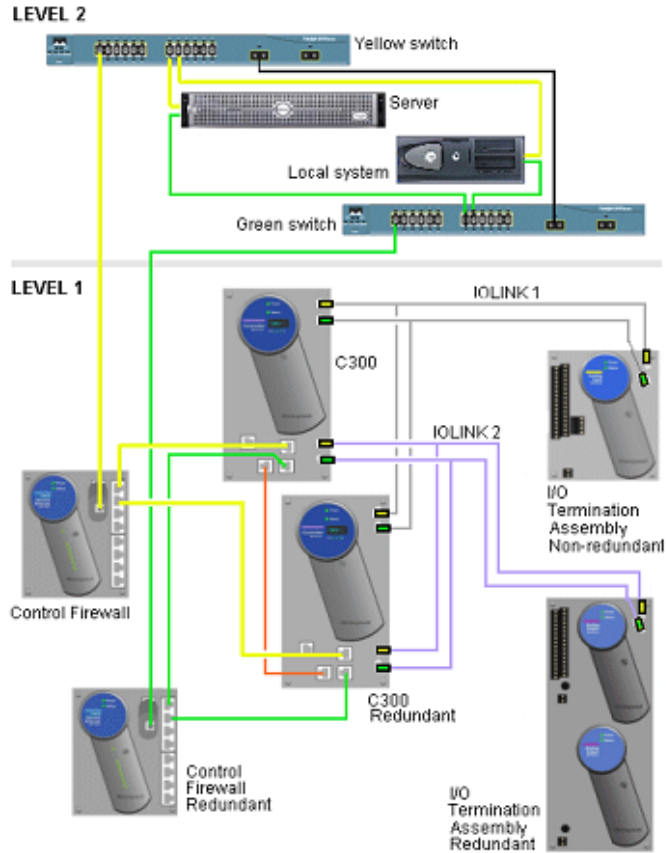

Figure 5: Series C I/O and C300 topology

3.2.1 Examining the topology rules

The following are the topology rules relating to the Series C I/O environment.

Refer to the following document for graphical representations of cabinet layouts depicting Series C, PMIO, FIM, and LLMUX hardware configurations. Control Hardware Planning Guide

Table 5: Topology rules

Item	Impact	Description
Redundancy	None	Redundancy capacity and performance is displayed while redundancy is present.

Item	Impact	Description
Switchover	Same as PM I/O	Series C I/O hardware and/or software can switchover, recover, and resume full view in a timeframe no greater than PM I/O.
Initialization	All Series C I/O per C300	Can be initialized in 60 seconds (+/- 25%) after cabinet-level loss power loss.
	1 I/O module	Can be initialized in 10 seconds (+/- 25%) after IOM level loss power loss.
Multiple I/O Links	2	Design allows the use of multiple Series C I/O Links in the same cabinet.
I/O Link performance	None	I/O Link networks perform at the current distance and IOP count specifications.
I/O Link capacity	40 max	Maximum of 40 redundant IOMs per link (for either Series C I/O or PM I/O).
IOMs / C300	64 max	Maximum of 64 redundant IOMs per C300 (for PM I/O).
	80 max	Maximum of 80 redundant IOMs per C300 (for Series C I/O).
Series C and PM I/O - combined	64	Design supports Series C and PM I/O FTAs in the same side of the cabinet. Current configuration prevents IOTA and FTAs in the same column.

3.3 Supported Series C I/O modules

The list of I/O modules below can be used on a Series C IOLINK. The IOLINK contains a function that enables programming and reprogramming the executable image (rather than substitution of a removable hardware component). The preferred method of delivery of the image is over the IOLINK.



Tip

Series C IOLINK cannot contain any PM I/O IOPs.

C300 IOLINK block parameter IOLINKTYPE is used to determine if the IOLINK supports either Series C I/O or PM I/O.

Table 6: Available I/O modules

IOM model names	IOM block name	Description	# of chnls	Similar to PMIO type	IOP model names
CU-PAIH01 CC-PAIH01	AI-HART	High Level Analog Input with HART (supports differential inputs on only channel 13 through channel 16) Refer to Attention	16	HLAIHART	
CC-PAIH02	AI-HART	High Level Analog Input with HART ((supports differential inputs on all 16 channel)	16	HLAIHART	
CC-PAIX02	AI-HART	High Level Analog Input with Differential/Single-ended non-HART (supports differential inputs on all 16 channels)	16	HLAI	
CC-PAIX01	AI-HL	High Level Analog Input with Differential non-HART (supports differential inputs on only channel 13 through channel 16) Refer to Attention	16	HLAI	
CU-PAIN01 CC-PAIN01	AI-HL	High Level Analog Input with non-HART	16	HLAI	
CC-PAIH51	AI-HART	1 Modem, High Level Analog Input with HART	16	HLAIHART	
CU-PAON01 CC-PAON01	AO	Analog Output with non-HART	16	AO16	
CU-PAOX01 CC-PAOX01	AO	Analog Output with non-HART Refer to Attention	16	AO16	
CU-PAIM01 CC-PAIM01	AI-LLMUX ¹	Low Level Analog Input Mux	64	LLMUX	
CC-PAIM51	AI-LLAI	Low Level Analog Input Mux	16	LLAI	

IOM model names	IOM block name	Description	# of chnls	Similar to PMIO type	IOP model names
CU-PAOH01 CC-PAOH01	AO-HART	Analog Output with HART	16	AO16HART	
CC-PAOH51	AO-HART	1 Modem, Analog Output with HART	16	AO16HART	
CU-PDIH01 CC-PDIH01	DI-HV	High Voltage Digital Input (IOM supports both 120 and 240 volts AC)	32	DI	
CU-PDIL01 CC-PDIL01	DI-24	Low Voltage Digital Input (24 volts DC)	32	DI or DI24V	
CC-PDIL51	DI-24	Low Voltage, Digital Input (24 volts DC)	32	DI	
CU-PDIS01 CC-PDIS01	DI-SOE	Low Voltage Digital Input (24 volts DC)	32	DISOE	Mx-PDIS12
CU-PDOB01 CC-PDOB01	DO-24B ²	Bussed Low Voltage Digital Output (24 volts DC)	32	DO_32	
CC-PDOD51	DO-24B	Bussed Low Voltage, Digital Output (24 volts DC)	32	DO32	
CU-PSOE01 CC-PSOE01	DI-SOE	Low Voltage Digital Input SOE (24 volts DC)	32	DISOE	
CC-PSP401	SP	Speed Protection	26		
CC-PSV201	SVP	Servo Valve Positioner	8		
CC-PPIX01	PIM	Pulse Input Module	8	PI IOP	
CC-PUIO01	UIO	Universal Input/Output Module	32		
CC-PUIO31	UIO	Universal Input/Output Module	32		
Series C Mark II IOM					
CC-PAIH01	AI-HART	High Level Analog Input with HART	16		
CC-PAOH01	AO-HART	Analog Output with HART	16		
DC-PDIL51	DI-24V	Digital Input (24 volt DC) without Open Wire Detection	32		
DC-PDIS51	DI-SOE	Low-Voltage Digital Input SOE-Low Resolution (24 volts DC) without Open Wire Detection	32		
DC-PDOD51	DO-24B	Bussed Low Voltage Digital Output (24 volts DC) without Open Wire Detection	32		
CC-PAIH51	AI-HART	1 Modem, High Level Analog Input with HART	16	HLAIHART	
CC-PAOH51	AO-HART	1 Modem, Analog Output with HART	16	AO16HART	
CC-PAIN01	AI-HL	High Level Analog Input with non-HART	16	HLAI	
CC-PAON01	AO	Analog Output with non-HART	16	AO16	

Following Series C IO modules introduced in Experion PKS R410.

HART Analog Input	CC -PAIH51
HART Analog Output	CC-PAOH51
Digital Input 24V DC	CC-PDIL51
Digital Output 24V DC	CC-PDOD51

These modules must be used only with Experion PKS R410 and later. These modules will not work as expected with earlier releases of Experion PKS. Using these with Experion releases prior to R410 by downgrading the firmware may render the module faulty and may not be possible to recover.

NOTES:

1. There are two models of High Level Analog Input such as, CU-PAIX01 and CU-PAIN01. The Module Hardware and the corresponding IOTAs are different and CU-PAIN01 is a new model. From the perspective of configuration and implementation, both High Level Analog Input models use the same IOM Block such as, AI-HL. It must be noted that the two models utilize the same configuration; online migration is not possible as mixed redundant pair is not possible. There are two models of Analog Output such as, CU-PAOX01 and CU-PAON01. Hence, similarly configuration, implementation, and interoperability constraints apply and CU-PAON01 is the new model.
2. Two new models of AI-HART (CC-PAIH02) and AI-HL (CC-PAIX02) modules are introduced to replace the older models of the AI-HART (CC-PAIH01) and AI-HL (CC-PAIX01) modules. The new models support both single-ended and differential inputs.
3. With R410, a new model of HART Analog Input CC-PAIH51 is introduced. The HART Analog Input CC-PAIH51 and Cx-PAIH01 use the same IOM block, that is, AI-HART. The configuration and implementation mentioned in note 1 applies to the HART Analog Input module.
4. With R410, a new model of HART Analog Output CC-PAOH51 is introduced. The HART Analog Output CC-PAOH51 and Cx-PAOH01 use the same IOM block, that is., AO-HART. The configuration and implementation mentioned in note 1 applies to the HART Analog Output module.
5. With R410, a new model of Digital Input 24V DC CC-PDIL51 is introduced. The Digital Input 24V DC CC-PDIL51 and Cx-PDIL01 use the same IOM block, that is, DI-24. The configuration and implementation mentioned in note 1 applies to the Digital Input 24V module.
6. With R410, a new model of Digital Output 24V DC CC-PDOD51 is introduced. The Digital Output 24V DC CC-PDOD51 and Cx-PDOB01 use the same IOM block, that is, DO-24B. . The configuration and implementation mentioned in note 1 applies to the Digital Output 24V module.
7. Starting with R430, a new model of Low Level Analog Input Mux CC-PAIM51 is introduced.
8. The UIO (CC-PUIO01) has 32 configurable input or output channels. Each channel can be configured as one of the following:
 - Analog Input (0-20mA or 4-20mA active)
 - Analog Output (4-20mA active)
 - Digital Input (with or without line monitoring)
 - Digital Output (with or without line monitoring)
9. The UIO (CC-PUIO31) module is introduced with R432 and has 32 configurable input or output channels that are identical to the UIO (CC-PUIO01) module.

3.3.1 Compatibility matrix between AI modules and differential AI modules

You can choose the AI modules based on your functionality requirements. The following table lists the functionalities and the respective AI modules.

If you want...	Then you must select...
AI HART/GIIS functionality	CC-PAIH02 module

If you want...	Then you must select...
Non-HART and Non-GIIS standard 2 wire transmitter (4-20mA input)	CC-PAIN01 module
Non-HART and Non-GIIS (1-5V input)	PAIX02 module

The following table lists the compatibility matrix between AI modules and differential AI modules for redundant and non-redundant configuration.

IOM	Redundant IOTA	Non-Redundant IOTA	AI			HART	No. of differential inputs
			4-20ma	1-5V	0-5V		
CC-PAIN01	CC-TAIN11	CC-TAIN01	X				None
CC-PAIH02	CC-TAIX11	CC-TAIX01	X	X	X	X	Channels 13 through 16
CC-PAIH02	CC-TAID11	CC-TAID01	X	X	X	X	Channels 1 through 16 ⁽¹⁾
CC-PAIX02	CC-TAIX11	CC-TAIX01	X	X	X		Channels 13 through 16
CC-PAIX02	CC-TAID11	CC-TAID01	X	X	X		Channels 1 through 16
CC-PAIH51	CC-TAIX61	CC-TAIX51		X			None

IOM	Redundant IOTA	Non-Redundant IOTA	IS	No. of differential inputs
CC-PAIH02	CC-GAIX11	CC-GAIX21	X	Not applicable
CC-PAIX02	CC-GAIX11	CC-GAIX21	X	Not applicable

Attention

The following module types are superseded by a new version of the module.

- CC-PAIH01 superseded by CC-PAIH02
- CC-PAIX01 superseded by CC-PAIX02
- CC-PAOX01 superseded by CC-PAON01

3.3.2 Compatibility matrix between AO modules and differential AO modules

The following table lists the compatibility matrix between AO modules and differential AO modules for redundant and non-redundant configuration.

IOM	Redundant IOTA	Non-Redundant IOTA	AO 4-20mA	HART	IS
CC-PAOH01	CC-TAOX11	CC-TAOX01	X	X	
CC-PAOH01	CC-GAOX11	CC-GAOX21	X	X	X
CC-PAOX01	CC-TAOX11	CC-TAOX01	X		
CC-PAOX01	CC-GAOX11	CC-GAOX21	X		X
CC-PAON01	CC-TAON11	CC-TAON01	X		

3.3.3 Difference between AI-HART modules Cx-PAIH01 and Cx-PAIH51

AI-HART module Cx-PAIH01	AI-HART module Cx-PAIH51
Supports Open Wire detection.	Does not support Open Wire detection.
Supports 64-HART Communication units.	Supports 16- HART Communication units.
Supports the following sensor types. <ul style="list-style-type: none"> • 1-5 V • 0-5V • 0.4-2V 	Supports only 1-5 V sensor type.
Supports the following input types. <ul style="list-style-type: none"> • Voltage • Current (2-wire or self-powered transmitters) 	Supports only current (2-wire or self-powered transmitters) input type.
Supports 16 input channels (single ended or differential).	Supports all single-ended input channels.
Supports the following input range. <ul style="list-style-type: none"> • 0 to 5V • 1 to 5V • 0.4 to 2V • 4-20 mA (through 250 Ω) 	Supports only 4-20 mA (through 200 Ω) inputs.
Supports all HART scan rates.	Supports all HART scan rates except 1 Sec Dynamic, 1 Sec Device, 2 Sec Device and Dynamic.
Supports differential voltage inputs.	Does not support differential voltage inputs.
Supports field calibration	Field calibration is not required.

3.3.4 Difference between AO-HART modules Cx-PAOH01 and Cx-PAOH51

AO-HART module Cx-PAOH01	AO-HART module Cx-PAOH51
Supports 64-HART Communication units.	Supports 16- HART Communication units.
Supports all HART scan rates.	Supports all HART scan rates except 1 Sec Dynamic, 1 Sec Device, 2 Sec Device and Dynamic.
Supports field calibration.	Field calibration is not required.
Supports OUTPUT READBACK.	Does not support OUTPUT READBACK.

3.3.5 Difference between bussed low voltage Digital Input modules Cx-PDIL01 and Cx-PDIL51

Digital Input module Cx-PDIL01	Digital Input module Cx-PDIL51
Supports Open Wire detection.	Does not support Open Wire detection.

3.3.6 Difference between low voltage Digital Output modules Cx-PDOB01 and Cx-PDOD51

Digital Output module Cx-PDOB01	Digital Output module Cx-PDOD51
Does not support Power fail diagnostics.	Supports Power fail diagnostics at module level to diagnose the output driver power failure (fuse/4 pin terminal block failure). When the failure is detected, OPFAIL soft fail is displayed on all the channels to take care of back initialization in upstream block. The following module level soft failure is displayed. 'Field Power Failure' Check the fuse or power supply status of the 4 pin terminal block when the error message is displayed.
Supports source output type.	Supports sink (open drain) output type.
Supports load current as 500mA.	Supports load current as 100mA.

3.3.7 Difference between AI-LLMUX and CC-PAIL51 modules Cx-PAIM01 and Cx-PAIM51

AI-LLMUX module Cx-PAIM01	AI-LLAI module Cx-PAIM51
Supports 64 input channels.	Supports 16 input channels.
Supports the following RTD types. <ul style="list-style-type: none"> Pt: 100 ohm DIN 4376 Pt: 100 ohm JIS C-1604 Ni: 120 ohm ED #7 Cu: 10 ohm SEER 	Supports a new RTD type, CU50Rtd, in addition to the RTD types supported by the AI-LLMUX.
Supports field calibration	Field calibration is not required.
Supports remote cold junction capability.	Does not support remote cold junction.
Requires an external HPM FTA to connect the field inputs to IOTA.	Field inputs can be directly connected to the IOTA.
Supports cold junction compensation range, -20 to +60 degree Celsius.	Supports cold junction compensation range, -40 to +70 degree Celsius.
Supports the operating temperature between 0 to +60 degree Celsius.	Supports the operating temperature between -40 to +70 degree Celsius.

3.3.8 Identifying supported Series C I/O modules

The Series C I/O model designations follow a 'XX-YZZZNN' format.

Where:

- XX is CC or DC
- CC is for the Series C Product Line.
 - The model number for every Series C product begins with a C designation for Series C.
- DC is for the Series C Mark II.
- Y is either C, E, F, G, H, K, M, P, PW, S or T
 - C = Control Processor
 - E = Enclosure
 - F = FTE
 - G = GI/IS Termination Assembly

- H = Hazardous Interface
- K = Cabling
- M = Mechanical
- P = I/O Module
- PW = Power
- S = Custom Interface
- T = Termination Assembly
- ZZZ is a particular function or model.
- NN is a series of model and can be used as additional model information -
NN +10 = Redundant complement to an IOTA.

**Tip**

Series C Mark II may not support all the above options.

3.3.9 Considerations for replacing or pairing Series C Analog I/O modules in a redundant configuration

In a redundant series C analog I/O module configuration, consider and complete the following before you replace or pair the modules.

Release	Hardware revisions of old modules	Hardware revisions of new modules	Considerations and actions for replacing or pairing modules
R301	<ul style="list-style-type: none"> • <=K for AI_HART and AI_HL • <=H for AO and AO_HART 	<ul style="list-style-type: none"> • >=M for AI_HART and AI_HL • >=J for AO and AO_HART 	You cannot pair an older hardware revision module with a latest hardware revision module. Replace your older module with a latest module.
R310 or later	<ul style="list-style-type: none"> • <=K for AI_HART and AI_HL • <=H for AO and AO_HART 	<ul style="list-style-type: none"> • >=M for AI_HART and AI_HL • >=J for AO and AO_HART 	<p>You can pair an older hardware revision module with a latest hardware revision module. However, complete the following after you replace one of the older modules:</p> <ol style="list-style-type: none"> 1. Migrate to the latest patch applicable for the release. 2. Migrate the applicable controllers 3. Update the firmware of the older hardware revision module. 4. Verify that the firmware versions of both the modules are indicated as “Green” in CTools.

Model number references for the affected Series C Analog I/O modules

Module model number	Module type	Hardware revisions of old modules	Hardware revisions of new modules
CC- PAIH01/02	AI_HART	<=K	>=M
CC- PAIX01/02	AI_HL	<=K	>=M
CC- PAOH01	AO_HART	<=H	>=J
CC- PAOX01	AO	<=H	>=J

3.4 Supported Series C I/O options

The following Series C I/O options are supported:

- I/O redundancy
- Power supply redundancy
- HART communications
- Galvanically Isolated/Intrinsically Safe IOTAs
- Remote I/O (using Fiber Optic I/O Extender)
- Corrosion Protection
- Harsh environment

3.4.1 Inspecting the I/O library

Series C module function blocks and I/O channel blocks are housed in the Series C I/O library of Control Builder.



Figure 6: Series C I/O library

3.4.2 Inspecting IOM function blocks

All IOM function blocks are associated with (children of) an IOLINK function block.

The Series C I/O IOM function blocks are the following:

- AI-HART

- AI-HL
- AI-LLMUX
- AI-LLAI
- AO
- AO-HART
- DI-24
- DI-HV
- DISOE
- DO-24B
- SP
- SVP
- PI
- UIO
- UIO-2

3.4.3 Inspecting channel function blocks

The Series C I/O Channel function blocks are the following:

Table 7: Series C I/O channel function blocks

Channel block name	Associated with IOM blocks
AICHANNEL	<ul style="list-style-type: none"> • AI-HART • AI-HL • AI-LLMUX¹ • AI-LLAI • UIO • UIO-2
AOCHANNEL	<ul style="list-style-type: none"> • AO • AO-HART • UIO • UIO-2
DICHANNEL	<ul style="list-style-type: none"> • DI-HV • DI-24 • DI-SOE • UIO • UIO-2
DOCHANNEL	<ul style="list-style-type: none"> • DO-24B² • UIO • UIO-2
SP_AI SP_AO SP_DI SP_DO SP_SPDVOTE SP_SPEED	<ul style="list-style-type: none"> • SP

Channel block name	Associated with IOM blocks
SVP_AI SVP_AO SVP_REGCTL SVP_DI	• SVP
PICHANNEL	• PI

3.4.4 Defining module containment

An individual channel within a Series C I/O block is often abbreviated as an IOC block. While an IOC block must be 'contained in' a Control Module (CM) in Control Builder, the IOC block actually resides within the associated IOM device. This means you change the execution state (EXECSTATE) of a CM independent of the IOC's point execution state (PTEXECST).

The screenshot shows a configuration window for a DO-24B block. The 'Execution State' dropdown is highlighted with a red box, and the value 'Idle' is visible in the selection area.

Figure 7: Execution State

The screenshot shows a configuration window for a DOCHANNEL block. The 'Point Execution State' dropdown is highlighted with a red box, and the value 'Inactive' is visible in the selection area.

Figure 8: Point Execution State

3.4.5 Temperature Derating for UIO

The maximum outside module temperature must be limited depending on the internal dissipation.

Attention

- Airflow through the module is assumed to be natural convection.
- Ensure that the UIO modules are installed in the correct position. A UIO module must be mounted in the upright position.

To determine the maximum acceptable outside module temperature for a typical configuration, perform the following steps.

1. Perform the **Internal Dissipation Calculation for UIO**.
 - a. Determine and record the actual configuration data.
 - b. Calculate the totals per dissipation contributor.
 - c. Add the totals of the previous step to determine the internal dissipation.
2. Using the **Temperature Derating Curves for UIO**, determine the maximum acceptable outside module temperature.

3.4.6 Internal dissipation calculation for UIO

To calculate the maximum outside module temperature, you require the IO configuration. The maximum dissipation caused by the kernel logic of the UIO module is a fixed value. The other dissipation contributions depend on the channel configuration.

Table 8: Dissipation Calculation

Dissipation contributor	Max. dissipation per channel (W)	Number of configured channels	Dissipation (W)
Kernel logic			5.5
DI w/ OWD; field impedance $\geq 5 \text{ k}\Omega$	0.01		
DI; closed contact; 3.5mA	0.085		
AI; $I < 24\text{mA}$; Current limited by field	0.05		
AI; $I > 24\text{mA}$; Current limited by UIO *	0.49		
DO; $I < 0.3\text{A}$	0.115		
DO; $I < 0.5\text{A}$	0.305		
AO; 500 Ω field impedance; $I < 23\text{mA}$	0.225		
AO; 250 Ω field impedance; $I < 23 \text{ mA}$	0.335		
AO; field impedance $< 250 \Omega$; $I < 23 \text{ mA}$	0.47		
AO; field impedance $< 250 \Omega$; $I < 20 \text{ mA}$	0.42		
<i>Total Power Dissipation (W)</i>			
<i>Max. outside module temperature °C</i>			

* Analog input current above 24mA must be avoided. Field devices for the analog input must be configured to drive current below 24mA. For example, 3.5mA, for sensor fault conditions to minimize the UIO internal power dissipation. The thin-line derating curve needs to be taken when you are using current above 24mA.

3.4.7 Temperature Derating curves for UIO

The following graph displays the maximum outside module temperature versus the internal power dissipation.

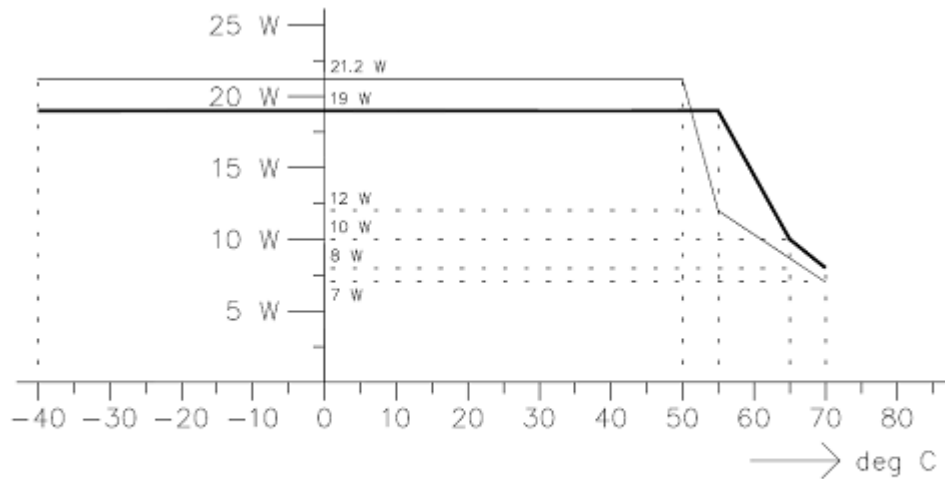

Thick line: applicable for most applications having $AO \leq 20\text{mA}$ and $AI \leq 24\text{mA}$

Thin line: applicable if one or more channels have $AO > 20\text{mA}$ or $AI > 24\text{mA}$

3.4.8 Maximum Temperature Alarm for UIO-2

The alarm threshold safe operating temperature is determined based on the I/O channel configuration of the module and the anticipated module inlet air temperature.

! Attention

- Airflow through the module is assumed to be natural convection.
- Ensure that the UIO modules are installed in the correct position. A UIO module must be mounted in the upright position.

To determine the maximum acceptable outside module temperature for a typical configuration, perform the following steps:

1. Perform the **High Temperature Limit Calculation for UIO-2**.
 - a. Determine and record the actual configuration data and the **Estimated Ambient** inlet air temperature.
 - b. Calculate the totals per dissipation contributor. For each channel type, multiply the total number of configured channels by the corresponding **Maximum Temperature Rise per channel** value.
 - c. Add the totals of the previous step to the **Estimated Ambient** temperature to determine the **High Temperature Limit Setting**. This limit value should not exceed 120 °C.
2. Enter the limit value into UIO-2 module configuration screen in Experion Control Builder.

3.4.9 High Temperature Limit Calculation for UIO-2

Table 9: Dissipation Calculation

Estimated Ambient [°C]		50		
Dissipation Contributor		Temperature Rise per channel [°C]	Number of channels (Total not to exceed 32)	Channel Contribution to Temperature Rise [°C]
DI	Closed contact	0.91	0	0.00
DO	<500 mA	1.06	0	0.00
AI	<20 mA	1.42	0	0.00
AO	<22 mA, 220 ohms	1.56	0	0.00
Total Number of Configured Channels			0	
High Temperature Limit Setting [°C]				50

3.5 I/O Link performance specifications

The concept of a Link Unit (LU) was introduced with PM I/O where a LU was defined as being roughly equivalent to one parameter read (or write) per second.

With the introduction of Series C I/O, the transmission rate of data on an IOLINK configured with Series C I/O is now double that of PM I/O.

! Attention

The Specification and Technical information is subject to change without notice and is superseded by information in applicable Experion product Specification and Technical data documents. Hence, for each Experion release, you are recommended to refer the applicable Specification and Technical data documents.

Table 10: Transmission rate of data on an I/O Link

I/O type	Link rate per second	Link Units per second
PM I/O	1 parameter read or write	1000
Series C I/O	1 parameter read or write	2000

Note: Refer to *Turbine Control User's Guide* for I/O link performance specification of the SPM and SVPM.

3.5.1 Reviewing Link Unit utilization

The Link Unit utilization cycle rate varies depending on the type of block being used. The following table defines the specifications for the various blocks.

Table 11: Link Unit utilization rates

Block names	Data processing	Link Units per cycle time	Cycle time
Every primary IOM	Event Collection	1	500 ms
Every secondary IOM	Event Collection	1	500 ms
DI-xxx IOM blocks	PV Scanning	1.75	IOM block's SCANRATE
DO-xxx IOM blocks	BACKCALC Scanning	1.25	IOM block's SCANRATE
AI-xxx IOM blocks	PV Scanning	5	IOM block's SCANRATE
AO-xxx IOM blocks	BACKCALC Scanning	5	IOM block's SCANRATE
AOCHANNEL	OP Store	1	OP connector's CM Execution Rate
status output for DOCHANNEL	SO Store	1	SO connector's CM Execution Rate
Pulse width modulation for DOCHANNEL	BACKCALC Scanning	1	IOM block's SCANRATE
Pulse width modulation for DOCHANNEL	OP Store	1	OP connector's CM Execution Rate

3.5.2 Reducing I/O Link traffic

If I/O Link overruns persist, you reduce the I/O Link traffic by:

- Increasing the value of the IOM's Scanning Rate parameter [SCANRATE] (i.e. increasing the time interval between IOM scans)

- Increase the Execution Period of Control Modules containing Output Channel blocks
- Reducing the number of IOMs configured
- Split the IOMs across multiple IOLINKS
- Check for presence of an address 'Chattering ' alarm events



Tip

Link IDs are only detected on their corresponding modules.

- Modules with Link ID 1 cannot detect Link ID 2.
- Modules with Link ID 2 cannot detect Link ID 1.

3.5.3 Event collection

Under normal conditions, every IOM configured on the I/O Link, whether primary or secondary, uses Link Units for event collection. This activity is periodic and can be accounted for, however; conditions in which numerous events and alarms are generated are unpredictable and may cause transient I/O Link overruns and delays in display updates. These transient overruns clear once the rush of events and alarms are collected.

3.5.4 PV and Back calculation scanning

The following I/O parameters are automatically scanned by the C300 as soon as the IOM block is loaded.

Table 12: I/O parameters scanned when the IOM is loaded

IOM block	Scanned parameters
AI-xxx	PV, PVSTS
AO-xxx	OP, INITREQ
DI-xxx	PVFL, BADPVFL
DO-xxx	SO, INITREQ, OP

The number of AI and DI channel blocks contained within CMs or SCMs:

- does not increase LU consumption.

The DO channel blocks contained in CMs and SCMs:

- does also not increase LU consumption for Back Calculation scanning, but LU consumption increases for each OP or SO store.

3.6 Universal Input/Output Module-2 (UIO-2)

Beginning with R432, a new Series C Universal Input/Output (UIO) module, the UIO-2, has been introduced. The UIO-2 not only supports all features and benefits offered by UIO, it also provides a few enhancements over the UIO. There are a few differences compared to the UIO too.

The UIO-2, driven by hardware miniaturization has resulted in a new design with reduced overall IOM and IOTA dimensions. Available in both redundant and non-redundant versions, the UIO-2 has a reduced footprint in the cabinet and increased density of IO point count per cabinet.

As the physical dimensions of the IOM and its IOTA are entirely different from the existing UIO, the UIO-2 is not a replacement for the UIO. The following sections provide a list of features of the UIO-2 and a list of significant differences between UIO-2 and UIO.

3.6.1 New and enhanced features of UIO-2

The UIO-2, in addition to providing all features provided by UIO, provides the following enhanced features beginning with R432:

- Is a single board module with physical dimension: 8.5 mm x 14.5 mm x 16 mm (5.5 mm dia) [4 x 4.5 dia x 14 width x 17 height]
- Dimensions of the redundant and non-redundant IOTAs are 12” and 9”, respectively
- Provides one HART modem per I/O channel
- Supports pulse counting on up to four of any of the 32 channels that are configured as DI
- Supports DO ganging within the following eight channel number groups: 1 - 4, 5 - 8, 9 - 12, 13 - 16, 17 - 20, 21 - 24, 25 - 28, and 29 – 32. However, ganging across these groups is NOT possible.

Beginning with Experion R500.1, the following additional enhancements have been provided :

- Supports Sequence Of Events (SOE) functionality for digital input signals on all 32 channels
- Supports 24 V NAMUR type input signals with current (Amps) levels in accordance with IEC 60947-5-6:1999 specifications.

3.6.2 UIO-2 and UIO-1 compared

The following table describes the differences between UIO-2 and UIO-1.

Table 13: UIO-2 and UIO-1 comparison

Feature	UIO-2	UIO-1
Board	Single board module	Three board module
IOTA dimensions	Redundant – 12” Non-redundant – 9”	Redundant – 18” Non-redundant – 12”
HART modem count	One HART modem per channel	Only two HART modems: one modem dedicated to channels 1-16 and a second modem dedicated to channels 17-32.
Pulse counting	Supported on a maximum of 4 channels where each channel can be any of the 32 channels configured as DI. Input pulse frequency less than or equal to 15 KHz is supported.	Up to 4 channels, within channels 15 to 18 only, are supported for pulse counting. Input pulse frequency of 10 KHz is supported.

Feature	UIO-2	UIO-1
DO ganging	Supported for 2, 3, or 4 channels within the following eight channel number groups: 1 - 4, 5 - 8, 9 - 12, 13 - 16, 17 - 20, 21 - 24, 25 - 28, and 29 - 32. However, ganging across these groups is NOT possible.	Supported for 2, 3, or 4 channels within any 4 channels. However, channels 32 and 1 cannot be ganged.
SOE	Supported on all 32 DI channels	Not supported.
NAMUR input signals	<p>Supported on all DI channels receiving 24 V NAMUR type input signals with current (Amps) levels in accordance with IEC 60947-5-6:1999 specifications.</p> <p>The DI channel can be configured to detect and report Open Wire and Short Circuit conditions.</p> <p>The following states are supported:</p> <ul style="list-style-type: none"> • Open Wire • ON • OFF • Short Circuit <hr/> <p> Note DI channels enabled for SOE cannot be configured to support NAMUR signal inputs.</p>	Not supported.

4 Series C I/O Installation and Upgrades

The Experion release utilizes new hardware designs including those for the controllers, I/O modules, and switches. The information contained in this section defines how to establish the various hardware connections and Series C I/O firmware.

To review planning the entire Series C Control System, refer to the Control Hardware Planning Guide's Planning Your Series C Control System.

Related topics

“Installation Declarations” on page 62

“Installing the Series C IOTA on the carrier” on page 65

“Mounting the I/O module on the IOTA” on page 67

“Grounding and power considerations - IOTA boards” on page 68

“Connecting IOMs and field devices through I/O Termination Assemblies” on page 70

“Powering the Series C system” on page 74

“Fusing - Series C IOTA boards” on page 75

4.1 Installation Declarations

**Attention**

This equipment shall be installed in accordance with the requirements of the National Electrical Code (NEC), ANSI/NFPA 70, or the Canadian Electrical Code (CEC), C22.1. It is supplied as 'open equipment' that is intended to be mounted on a sub-panel within an enclosure. The suitability of the enclosure and installed system shall be acceptable to the local 'authority having jurisdiction,' as defined in the NEC, or 'authorized person' as defined in the CEC.

**Electrostatic discharge**

Electrostatic discharge can damage integrated circuits or semiconductors if you touch connector pins or tracks on a printed wiring board.

- Touch a grounded object to discharge static potential
 - Wear an approved wrist-strap grounding device
 - Do not touch the wire connector or connector pins
 - Do not touch circuit components
 - If available, use a static safe workstation
 - When not in use, keep the component in its static shield box or bag
-

**WARNING**

Unless the location is known to be non-hazardous, do not:

- Connect or disconnect cables
- Install or remove components
- Install or remove isolators

While the control system is powered.

4.1.1 Introduction

The following figure represents the main cabling of the Series C300 controller, Control Firewall, and I/O IOTA boards.

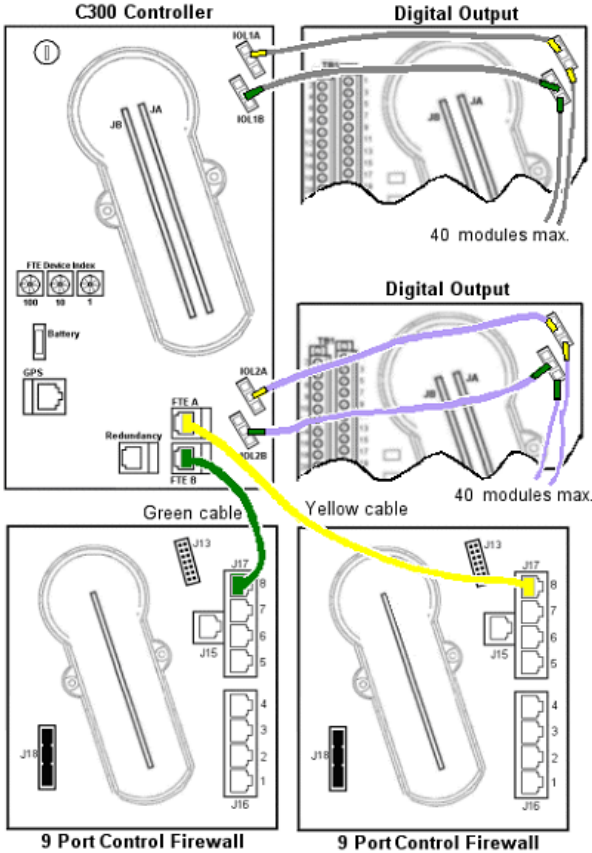

Figure 9: Series C board connections

4.1.2 I/O Link Address Jumpers

The I/O Link Address is configured using a push-on color-coded jumper with a printed number (1-40) that must be installed on each IOTA.

Attention

- IO modules configured using Gray address jumpers must be connected to I/O Link 1 on the C300.
- IO modules configured using Violet address jumpers must be connected to I/O Link 2 on the C300.
- IO modules connected to the wrong I/O Link do not communicate each other.
- The IOM Number parameter (IOMNUM) specifies the address of the module on the I/O Link and must match the I/O Link address jumper on the IOTA
- Only the Honeywell provided address jumper tiles must be used. When changing address jumpers, you must ensure that:
 - (1) The IOM is disconnected from the Link,
 - (2) Power cycled after the address change, then
 - (3) The IOM may be re-connected it back to the Link

4.1.3 Cabling

The following graphic is an example of possible configuration connections with regards to the Series C I/O cabinet. Your configuration may vary based on the module layout of your cabinet. The following table defines cable type and usage in the graphic below.

Table 14: Series C I/O cable types

Cable	Color	Purpose
FTE -A	Yellow	Connect controller to firewall (point-to-point)
FTE - B	Green	Connect controller to firewall (point-to-point)
FTE - Redundant	Orange	Private path between primary and secondary controller (point-to-point)
IOL1A	Grey/yellow	Connect controller to I/O
IOL1B	Grey/green	Connect controller to I/O
IOL2A	Violet/yellow	Connect primary controller to secondary controller and then to I/O
IOL2B	Violet/green	Connect primary controller to secondary controller and then to I/O

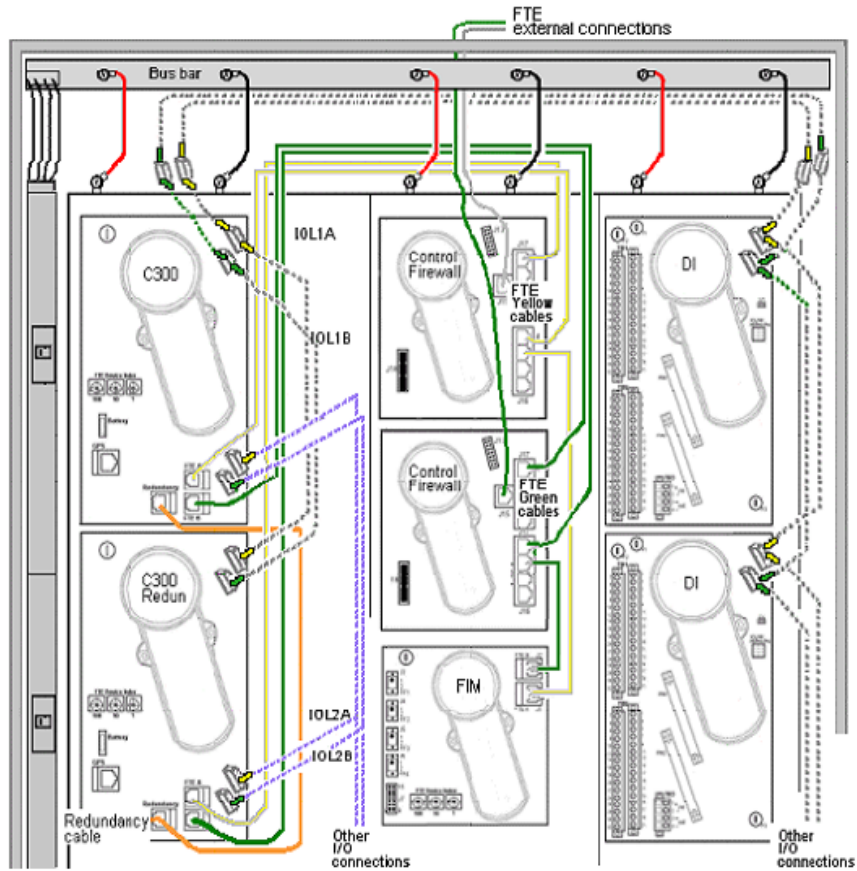

Figure 10: Series C cabling

4.2 Installing the Series C IOTA on the carrier

- You can use a redundant IOTA to support a non-redundant Series C IOM application. Just be sure to install the non-redundant Series C IOM in the primary location on the IOTA.
- Be sure the enclosure is connected to a protective earth ground using #8 AWG solid copper wire. There should be metal to metal contact between the grounding bus bar and the enclosure as well as the carrier.

Prerequisites

Carrier for mounting IOTA is installed in a cabinet or desired mounting location.

- Power supply is installed.
- Control firewall is installed.
- All wiring and pre-fabricated cables are available and labeled as applicable.
- Be sure all power is turned off at the installation location.
- You have the mounting hardware supplied with the components.

Mounting the IOTA

- Select desired mounting location on carrier and align mounting holes in IOTA with screw-hole locations on the carrier. Be sure component side of IOTA is facing up.

6 inch IOTA board 4 mounting screws

9 inch IOTA board 6 mounting screws 12 inch IOTA board



Attention

When mounting the either the 9 or 12 inch IOTA board, it is recommended to secure the three mounting screws on one side (either left or right) and then secure the other side.

Securing the four corner screws and the two middle screws may cause bowing of the board and impact the alignment of the IOTA board to the carrier holes and is not recommended.



CAUTION

The IOTA power and ground screws can bind during installation or removal if the mounting screws are fully secured before the power/ground screws are installed.

Recommended sequence:

1. Secure the IOTA to the carrier tightening the IOTA's mounting screws only half-way. Insert the spacers and washers between bottom of IOTA and top of carrier.
2. Install the 24V (power) and ground (common) **screws fully into the bus bars**, torquing the screws to 5-inch pounds.
3. Finish installing the IOTA by **tightening the IOTA's mounting screws only full-way**, torquing the screws to 3-inch pounds

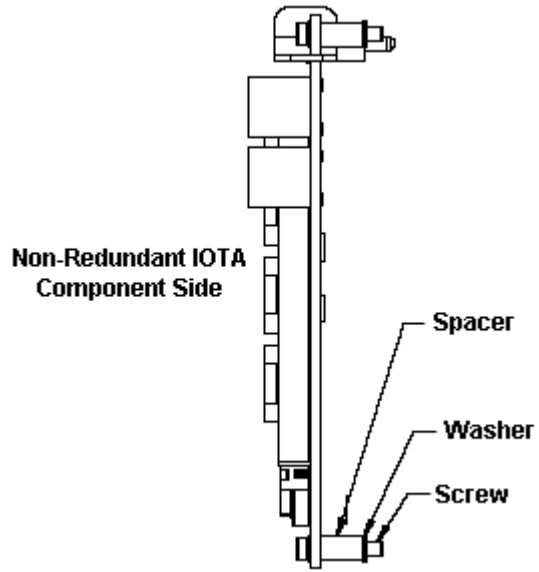

4.3 Mounting the I/O module on the IOTA

Prerequisites

It is recommended to attach the IOTA board to the Backplane prior to mounting the module to the IOTA. Ensure the following:

- IOTA is mounted on the Backplane.
- Power supply is installed.
- Control firewall is installed.
- All wiring and pre-fabricated cables are available and labeled as applicable.
- All power is turned off at the installation location.
- You have the mounting hardware supplied with the components.

Mounting the module

- 1 Insert the module onto the IOTA board making sure that the circuit board mates properly with the IOTA board connector.
- 2 Secure the module to the:
 - IOTA board - with two screws located on each side of the plastic cover.
 - Backplane - with the long gray plastic screw located on the module's face.



CAUTION

Use only a #2 Phillips screw-driver to carefully loosen or tighten the long gray plastic screw. Do not use either a #1 Phillips screw-driver or a battery-powered screw-driver to remove or install the plastic screw as this can damage the screw head.

4.4 Grounding and power considerations - IOTA boards

The Series C cabinet allows mounted carriers that support the attachment of the IOTA boards. By making these connections, power, and chassis, grounding is provided to the IOTA board.

4.4.1 Testing for power

**CAUTION**

Extreme care must be taken when testing for power at the Series C bus bars. Improper testing can result in an electrical short circuit, which will impact all modules attached to the channel carrier assembly.

Never use a test probe at an unattached IOTA's 24V screw hole. The probe can potentially touch the back channel assembly causing a short circuit.

The following locations are recommended for testing power:

Preferred location if IOTAs are attached

- Center of the screw that attaches the IOTA to the 24V bus bar.

Preferred location if IOTAs are NOT attached.

- Center of the screw of top connection terminal for power cable.
-

Testing for power at IOTA screw

- 1 Insert the test probe at the center of the screw that attaches the IOTA to the 24V power connection.
- 2 This concludes this procedure.

Testing for power at 24V bus bar top terminal

- 1 Carefully pull the red cap from the top of the terminal. It remains attached to the power cable.
 - Insert the test probe at the center of the screw to the 24V power terminal.
- 2 Carefully pull the black cap from the top of the terminal. It remains attached to the ground cable. Insert the test probe at the center of the screw to the COM ground terminal.
- 3 Replace the both caps.
- 4 This concludes this procedure.

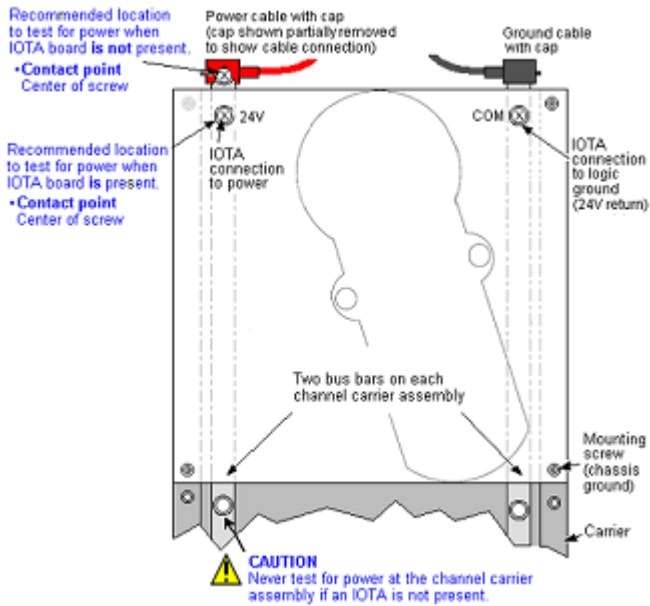

Figure 11: Grounding and power connections

4.5 Connecting IOMs and field devices through I/O Termination Assemblies

All connections between IOMs and field devices are through I/O Termination Assemblies (IOTAs). IOTAs are sometimes connected to ancillary hardware that pre-conditions the signal for use in Experion.

The following table defines the relationship between IOM type and the ancillary hardware.

Table 15: IOM types and ancillary hardware

If IOM type is	Then the ancillary hardware
DO Digital Output	takes the output signal and drives a set of relays
AI LLMUX	can be one to four Field Termination Assemblies.

These FTA's pre-condition and package the signals before they are received by the IOTA.

To simplify system hardware selection and to minimize spare parts requirements, IOMs can be used with various types of IOTAs. The following table provides a list of IOMs, their associated IOTAs, and ancillary hardware. All IOM models listed within the same cell can be installed on any of the IOTAs listed in the adjacent cell.



Attention

Connecting Series C IOM's into a Galvanically Isolated / Intrinsically Safe (GI/IS) environment requires specific GI/IS IOTAs.

Refer to the following for GI/IS IOTAs and the IOMs they support: "GI/IS IOTA models" on page 596

Table 16: IOMs, IOTAs, and ancillary cards

IOM block type	IOM model number	IOTA model number	IOTA description ⁷	IOTA supported FTAs or ancillary cards
AI-HART	Cx-PAIH01 Refer to Attention	Cx-TAIX01	AI, non-redundant	None
		Cx-TAIX11	AI, redundant	None
		Cx-GAIX11	AI, GI-IS, non-redundant	MTL4541 MTL4575
		Cx-GAIX21	AI, GI-IS, redundant	MTL4544
		CC-TAID01	Analog Input, Non-redundant, 16 ch. differential	
	Cx-PAIH51	Cx-TAIX51	AI, non-redundant	None
		Cx-TAIX61	AI, redundant	None
AI-HART Differential/ Single-ended	CC-PAIH02	Cx-TAIX01	Analog Input, Non-redundant, 4 ch. differential	None
		Cx-TAIX11	Analog Input, Redundant, 4 ch. differential	None
		Cx-GAIX11	Analog Input, GI-IS, Redundant, no differential, 4-20 mA only	MTL4544
		Cx-GAIX21	Analog Input, GI-IS, Non-redundant, no differential, 4-20 mA only	MTL4541 MTL4575
		CC-TAID11	Analog Input, Redundant, 16 ch. differential	None

IOM block type	IOM model number	IOTA model number	IOTA description ⁷	IOTA supported FTAs or ancillary cards
AI-HL	Cx-PAIN01	Cx-TAIN01	AI, Non-redundant	None
		Cx-TAIN11	AI, Redundant	None
AI-HL	Cx-PAIX01 Refer to Attention	Cx-TAIX01	AI, Non-redundant	None
		Cx-TAIX11	AI, Redundant	None
		Cx-GAIX11	AI, GI-IS non-redundant	MTL-4541 MTL-4575
		Cx-GAIX21	AI, GI-IS redundant	MTL-4544
AI-HL Differential/ Single-ended	CC-PAIX02	CC-TAIX01	AI, non-redundant	None
		CC-TAIX11	AI, redundant	None
		Cx-GAIX11	AI, GI-IS, non-redundant	MTL4541 MTL4575
		Cx-GAIX21	AI, GI-IS, redundant	MTL4544
		CC-TAID01	AI, non-redundant	None
		CC-TAID11	AI, redundant	None
AI	CC-PAIN01	CC-TAIN01	Analog Input, Non-redundant, no differential, 4-20 mA only	None
		CC-TAIN11	Analog Input, Redundant, no differential, 4-20 mA only	None
AI-LLMUX	Cx-PAIM01	Cx-TAIM01 ⁴ (note 1a)	LLMUX, non-redundant, non-coated	Mx-TAMT04 Mx-TAMR04 Mx-TAMT14
AI-LLAI	Cx-PAIM51	Cx-TAIM51	LLAI, non-redundant, non-coated	None
Cx-TAIM51	LLAI, non-redundant, non-coated			None
AO-HART	Cx-PAOH01	Cx-TAOX01	AO, non-redundant	None
		Cx-TAOX11	AO, redundant	None
		Cx-GAOX11	AO, GI-IS non-redundant	MTL4546C
		Cx-GAOX21	AO, GI-IS redundant	MTL4549C
	Cx-PAOH51	Cx-TAOX51	AO, non-redundant	None
		Cx-TAOX61	AO, redundant	None
AO	Cx-PAOX01	Cx-TAOX01	AO, Non-redundant	None
		Cx-TAOX11	AO, Redundant	None
		Cx-GAOX11	AO, GI-IS, Non-redundant	MTL4546C
		Cx-GAOX21	AO, GI-IS, Redundant	MTL4549C
AO	Cx-PAON01	Cx-TAON01	AO, Non-redundant	None
		Cx-TAON11	AO, Redundant	None
DI-HV	Cx-PDIH01	Cx-TDI110	DI, 120VAC non-redundant	None
		Cx-TDI120	DI, 120VAC redundant	None
		Cx-TDI220	DI, 240VAC non-redundant	None
		Cx-TDI230	DI, 240VAC redundant	None

IOM block type	IOM model number	IOTA model number	IOTA description ⁷	IOTA supported FTAs or ancillary cards
DI-HV PROX	Cx-PDIH01	CC-TDI151	DI,120VAC non-redundant	None
DI-24	Cx-PDIL01	Cx-TDIL01	DI-24V, non-redundant	None
		Cx-TDIL11	DI-24V, redundant	None
		Cx-GDIL11	DI-24VDC, GI-IS, redundant	MTL4516 MTL4517
		Cx-GDIL21	DI-24VDC, GI-IS, non-redundant	MTL4510
		Cx-GDIL01	DI-24VDC, GI-IS, redundant (for expander)	MTL4511
		Cx-SDXX01	GI-IS expander	MTL4511
	Cx-PDIL51	Cx-TDIL51	DI-24V, non-redundant	None
		Cx-TDIL61	DI-24V, redundant	None
DI_SOE	Cx-PSOE01 (note 4)	Cx-TDIL01	DI-24V, non-redundant	None
DO-24B	Cx-PDOB01	Cx-TDOB01	DO-24V, bussed, non-redundant	None
		Cx-TDOB11	DO-24V, bussed, redundant	None
		Cx-TDOR01	DO- High Voltage Relay, non-redundant	Cx-SD0R01 ² (note 2)
		Cx-TDOR11	DO- High Voltage Relay, redundant	Cx-SD0R01 ² (note 2)
		Cx-GDOL01	DO-24VDC, GI-IS, redundant (for expander)	MTL4521
		Cx-SDXX01	GI-IS expander	MTL4521
	Cx-PDOD51	Cx-TDOD51	DO-24V, bussed, non-redundant	None
		Cx-TDOD61	DO-24V, bussed, redundant	None
SVPM	CC-PSV201	CC-TSV211	Servo Valve Positioner IOTA, Redundant, Coated	None
SPM	CC-PSP401	CC-TSP411	Speed Protection IOTA, Redundant, Coated	None
PI	CC-PPIX01	CC-TPIX11	Pulse Input w/ Fast Cutout, Redundant	None
UIO	CC-PUIO01	CC-TUIO01	UIO, Non-Redundant	None
		CC-TUIO11	UIO, Redundant	
UIO-2	CC-PUIO31	CC-TUIO31	Universal IO-2, non-redundant, coated	None
		CC-TUIO41	Universal IO-2, redundant, coated	
DI-24	DC-PDIL51	DC-TDIL01	DI 24V IOTA (Non-Redundant)	None
		DC-TDIL11	DI 24V IOTA (Redundant)	
DI-SOE	DC-PDIS51	DC-TDIL01	DI 24V IOTA (Non-Redundant)	None
		DC-TDIL11	DI 24V IOTA (Redundant)	
DO-24B	DC-PDOD51	DC-TDOD51	DO 24V Bussed without RB IOTA (Non-Redundant)	None
		DC-TDOD61	DO 24V Bussed without RB IOTA (Redundant)	

NOTES

1. Cx-TAIM01 - This does NOT require the MU-TLPA02 Power Adapter and supports in-cabinet configuration or in a suitable enclosure up to 1,000 feet remote from the LLMUX IOTA as displayed in Figure 15.
2. Cx-TAIM21 requires the MU-TLPA02 Power Adapter and can be mounted in-cabinet and remotely.
3. One CC-KREBxx uncoated cable is used to connect the IOTA to the relay extension board.
4. One CC-KREBxx coated cable is used to connect the IOTA to the relay extension board.
5. Bussed IOM (PDOB01) is used for both bussed outputs and relay outputs, however, only relay outputs require the additional card.
6. Redundantly configured IOMs must be installed on a redundant IOTA.
7. Non-redundant IOMs can be installed on non-redundant and redundant IOTAs. However, when installed on a redundant IOTA, non-redundant IOMs must be installed in the upper IOM slot of the redundant IOTA.
8. The IOTA type used for Series C IO DI-24V is used with the DI-SOE IOM also.
9. Non-redundant differential IOTA (CC-TAID01) length is 9', non-redundant IOTA (CC-TAIX01 and CC-TAIN01) length is 6', and differential redundant IOTAs (CC-TAID11, CC-TAIN11, and CC-TAIX11) length is 12'.
10. A third level of connector is available for all differential mode connections as an extension of channel 13 through 16 terminals for all 16 channels.
11. Differential configuration does not require any custom wiring as the IOTAs (CC-TAID01 and CC-TAID11) performs it internally.
12. Two new models of AI-HART (CC-PAIH02) and AI-HL (CC-PAIX02) modules are introduced to replace the older models of the AI-HART (CC-PAIH01) and AI-HL (CC-PAIX01) modules. The new models support both single-ended and differential inputs.
13. With R410, new models of AI-HART (Cx-PAIH51), AO-HART (Cx-PAOH51), DI-24V (Cx-PDIL51), and DO-24B2 (Cx-PDOD51) are introduced.

4.6 Powering the Series C system

Power systems for the Series C control hardware provides:

- optional redundant power supplies with separate mains power feeds
- optional system battery backup is also available, and
- a memory RAM battery is provided to supply memory retention power for the C300 Controller

The capabilities and options available with the Series-C power system are very similar to those available with the Process Manager Power System.

Refer to the Series C Power Supply in the C300 Controller User Guide additional power system information.

4.7 Fusing - Series C IOTA boards

Series-C I/O modules are constructed to support normal field failures, wiring errors and conditions such as a shorted wire. All Series-C IOTAs contain at least one fuse that provides protection for catastrophic errors in the IOTA, IOM and other elements of the Series-C system. In normal operation as well as many abnormal operations, the fuse element should not blow.

The following attributes apply to all Series-C I/O modules:

- 24V DC power is protected by a fuse mounted on the IOTA.
- For redundant IOTAs, a fuse is provided for each IOM. If one fuse element were to blow, the partner IOM continues to operate.

**Attention**

- In virtually all instances of normal field failure, the I/O module will recover without any maintenance action such as replacing a component or fuse.

To access the parts information for the fuses associated with each board and module, refer to “Series C recommended spares” on page 542 in the Recommended Spare Parts section.

5 Series C IOTA Pinouts

Related topics

- “Analog Input IOTA Models CC-TAIX01, CC-TAIX11” on page 78
- “Analog Input non-HART/HARTIOTA Models Cx-TAIX51, Cx-TAIX61” on page 89
- “Non-HART Analog Input IOTA (Models CC-TAIN01, CC-TAIN11)” on page 95
- “Differential Analog input IOTA (Models CC-TAID01 and CC-TAID11)” on page 102
- “Analog Output IOTA Models CC-TAOX01, CC-TAOX11, CC-TAON01 and CC-TAON11” on page 115
- “Analog Output HART IOTA Models Cx-TAOX51, Cx-TAOX61” on page 122
- “Low Level Analog Input Mux (LLMUX) IOTA Models CC-TAIM01” on page 126
- “Digital Input High Voltage IOTA Models CC-TDI110, CC-TDI120, CC-TDI220, CC-TDI230” on page 130
- “Digital Input High Voltage PROX IOTA Model Cx-TDI151” on page 135
- “Digital Input 24V IOTA Models CC-TDIL01, CC-TDIL11” on page 139
- “Digital Input 24V IOTA Models Cx - TDIL51, Cx - TDIL61” on page 147
- “Digital Output 24V IOTA Models CC-TDOB01, CC-TDOB11” on page 153
- “Digital Output 24V IOTA Models Cx-TDOD51, Cx-TDOD61” on page 158
- “Digital Output Relay Module IOTA Models CC-TDOR01, CC-TDOR11” on page 163
- “Digital Output Relay Extender board Models CC-SDOR01” on page 165
- “Speed Protection Module IOTA Model CC-TSP411” on page 169
- “Servo Valve Positioner Module IOTA Models CC-TSV211” on page 176
- “Universal Input/Output IOTA Models CC-TUIO01 and CC-TUIO11” on page 184
- “Universal Input/Output Phase 2 IOTA Models CC-TUIO31 and CC-TUIO41” on page 194
- “Low Level Analog Input (LLAI) Module IOTA model CC-TAIL51” on page 204
- “Pulse Input Module IOTA Model CC-TPIX11” on page 207
- “Upgrading Firmware in Series C I/O components” on page 209

5.1 Analog Input IOTA Models CC-TAIX01, CC-TAIX11

The Series C Analog Input IOTA board is represented by the following information and graphic.

To access the parts information for the:

- module
- IOTA
- terminal plug-in assembly, and
- fuses

associated with this board and module, refer to Analog Input in the Recommended Spare Parts section.

Series C Analog Input 6 inch, non-redundant IOTA is displayed.

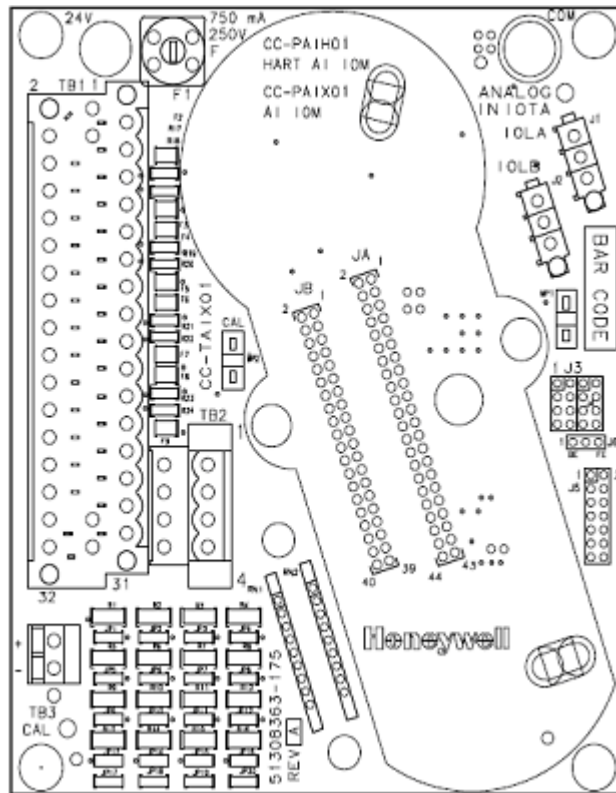

Figure 12: Series C Analog Input 6 inch, non-redundant IOTA

Note: All I/O field terminations accept up to 14 gauge stranded wire.

To properly wire, your module to the Series C Analog Input IOTA board with terminal block 1 (TB1) and terminal block 2 (TB2), use the following tables.

Table 17: AI 6 inch, non-redundant - terminal block 1

Terminal block 1		
Channel	Return screw	Power screw
Channel 1	2	1
Channel 2	4	3
Channel 3	6	5

Terminal block 1		
Channel	Return screw	Power screw
Channel 4	8	7
Channel 5	10	9
Channel 6	12	11
Channel 7	14	13
Channel 8	16	15
Channel 9	18	17
Channel 10	20	19
Channel 11	22	21
Channel 12	24	23
Channel 13	26	25
Channel 14	28	27
Channel 15	30	29
Channel 16	32	31

Table 18: AI 6 inch, non-redundant - terminal block 2

Terminal block 2 - Low side of the differential inputs			
If this TB2 screw is used	Then this channel is used	And this jumper is clipped	
1	13	JP17	<p>In the example below, cutting J20 would configure channel 16 for differential operation and pin 4 would be the low side (-) of the input signal.</p> <p>Refer to “Custom wiring - Analog Input module” on page 81 for additional power connection possibilities.</p>
2	14	JP18	
3	15	JP19	
4	16	JP20	

Jumpers are utilized to support the following conditions:

Table 19: Jumpers to support Analog Input connections

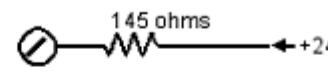
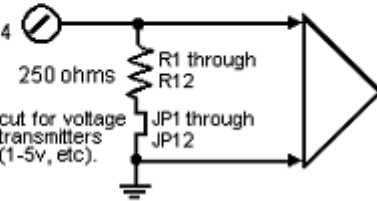
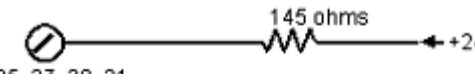
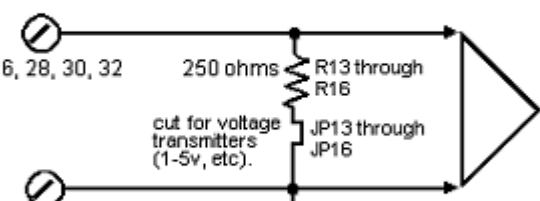
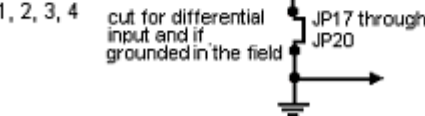
Channels	Signal screw
<p>For channels 1 through 12</p>	<p>Each channel (1 through 12):</p> <ul style="list-style-type: none"> • has a corresponding jumper. Therefore, channel 1's jumper would be JP1, and so forth. • the jumper must be cut if connected to voltage transmitters (1-5v. etc.) <p>Channels 1 through 12</p> <p>TB1 pin 1, 3, 5, 7, 9, 11, 13 15, 17, 19, 21, 23</p>  <p>TB1 pin 2, 4, 6, 8, 10, 12, 14 16, 18, 20, 22, 24</p> 
<p>For channels 13 through 16</p>	<p>Each channel 13 through 16:</p> <ul style="list-style-type: none"> • has a corresponding jumper. Therefore, channel 13's jumper would be JP13, and so forth. • the jumper must be cut if connected to voltage transmitters (1-5v. etc.) <p>Jumpers J17 through J20 are used with Terminal Block 2 (TB2) and are used if the device is grounded in the field.</p> <p>Channels 13 through 16</p> <p>TB1 pin 25, 27, 29, 31</p>  <p>TB1 pin 26, 28, 30, 32</p>  <p>TB2 pin 1, 2, 3, 4</p> 

5.1.1 Field wiring and module protection - Analog Input module

Individual field wiring is protected by an internal protection circuit permitting:

- Short circuit protection of input for field short circuits. Protection suitable for Division 2 non-incendive / Zone 2 non-arcing.
- Each signal can be shorted in the field with no damage to module or board. Other channels on the same IOM will not be affected

5.1.2 Two-wire transmitter wiring - Analog Input module

The AI IOM/IOTA is optimized for use with classic two-wire transmitters. All 16 channels can accept inputs from two-wire transmitters without any special wiring or jumper options.

The standard usage is to:

- reserve the first 12 channels of the AI IOM/IOTA for classic two-wire transmitters, and
- use the last 4 channels of the IOM/IOTA to interface any of the supported input styles (including two-wire transmitters).

Depending on the input style applied to channels 13 through 16, you may need to cut jumpers on the IOTA and apply wiring to the TB2 terminal block on the IOTA. This is discussed in detail in the following sections.

5.1.3 Non two-wire transmitter wiring - Analog Input module

The IOTA is pre-engineered (without custom wiring) to accept sources that are not two-wire transmitters, but you must use channels 13 through 16.

When sources other than two-wire transmitters are to be interfaced and you have more than 4 per IOTAs, then:

- the first four must be interfaced to channels 13 through 16, and
- the remainder may be able to interface to channels 1 through 12 (depending on input style) but you must perform some degree of custom wiring.

NOTE: There are some input styles that simply cannot be applied to channels 1 through 12 - if that applies to you then you will likely need to purchase an additional IOM/IOTA.



CAUTION

The jumpers on the IOTA are non-repairable; once cut, they stay cut. Careful planning is a must.

5.1.4 Custom wiring - Analog Input module

Custom wiring means:

- using additional wires to TB2 (beyond their intended purpose for channels 13 through 16)
- and/or using wires to another termination area in the cabinet engineered on a project-basis.

Some of the styles (other than two-wire transmitter):

- can be applied to channels 1 through 12 with the use of custom wiring.
- Other cannot be applied to channels 1 through 12 at all.

Table 20: Custom wiring to support Analog Input

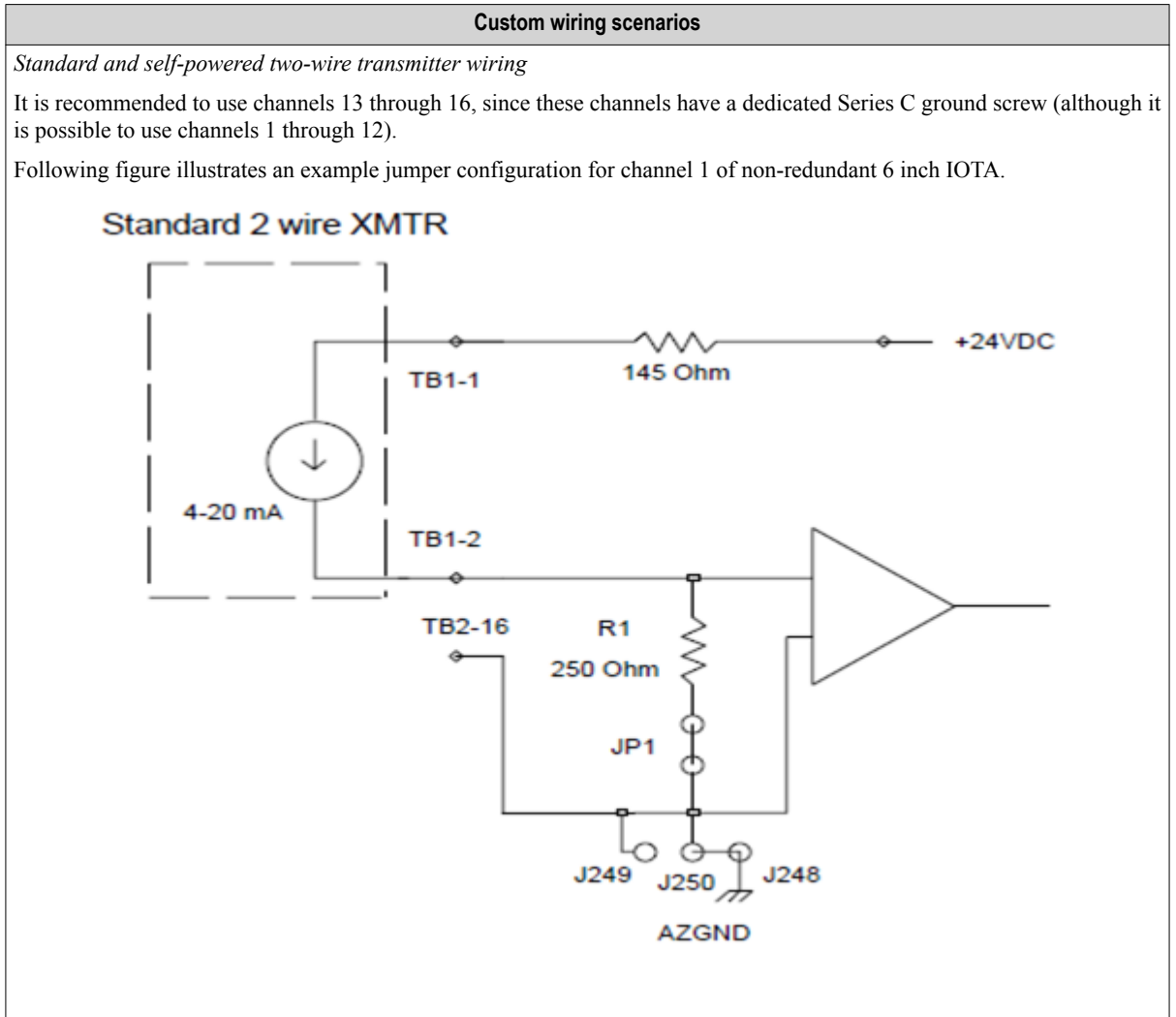

Custom wiring scenarios

Self-powered transmitter with EPKS system ground

It is recommended to use channels 13 through 16, since these channels have a dedicated Series C ground screw (although it is possible to use channels 1 through 12).

For the following example:

- Channel 13 is used
- No jumpers need to be cut.
- The wire-pair is terminated to TB1-26 and TB2-1
- TB1-25 is not used.

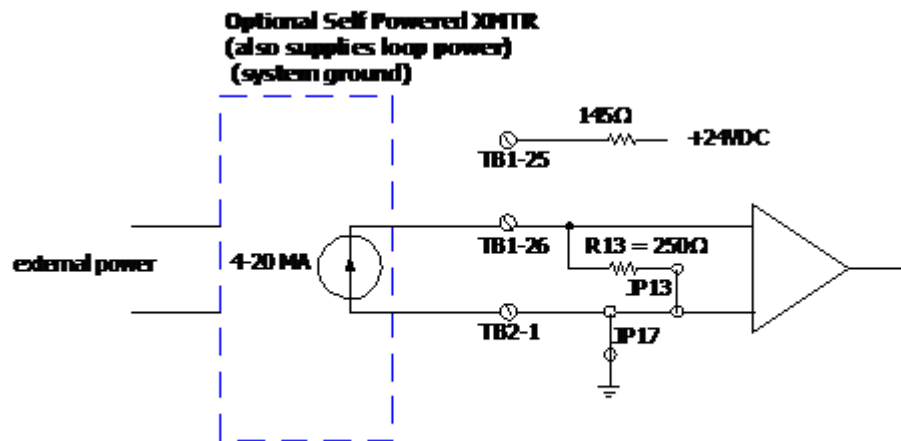

Custom wiring scenarios

Self-powered transmitter with device grounded

This case can only be applied to channels 13 through 16 and the corresponding jumper must be cut.

For the following example:

- Cutting jumper JP-17 permits the transmitter's ground to be utilized
 - Series C ground is then not used. Device ground must remain within the specified common-mode limits of the AI IOM.
 - JP17 through JP20 are for channels 13 through 16, respectively.
- The wire-pair is terminated to TB1-26 and TB2-1.
- TB1-25 is not used.

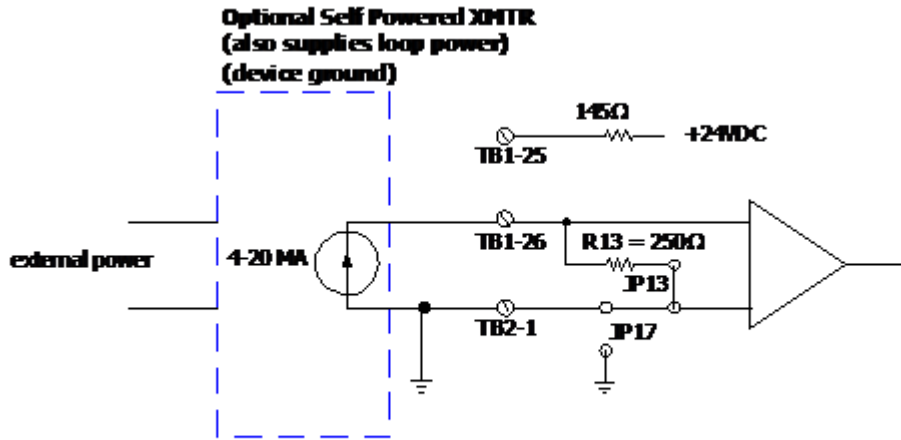

Self-powered 3-wire transmitter (system ground)

It is recommended to use channels 13 through 16, since these channels have 3 screws per channel (although it is possible to use channels 1 through 12).

For the following example:

- Channel 13 is used
- No jumpers need to be cut
- The three wires are terminated to TB1-25, TB1-26 and TB2-1

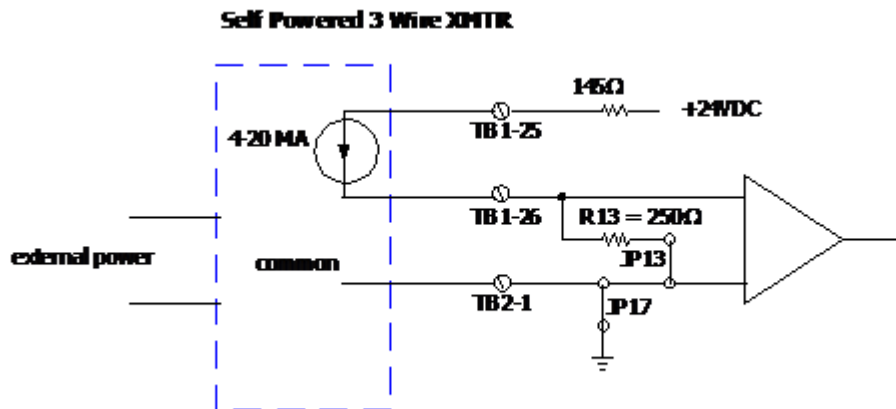

Custom wiring scenarios

Voltage input (system ground)

It is recommended to use channels 13 through 16, since these channels have a dedicated Series C ground screw (although it is possible to use channels 1 through 12).

For the following example:

- Channel 13 is used.
- Jumper JP13 (for the 250 ohm spool) needs to be cut.
- The wire-pair is terminated to TB1-26 and TB2-1.
- TB1-25 is not used.

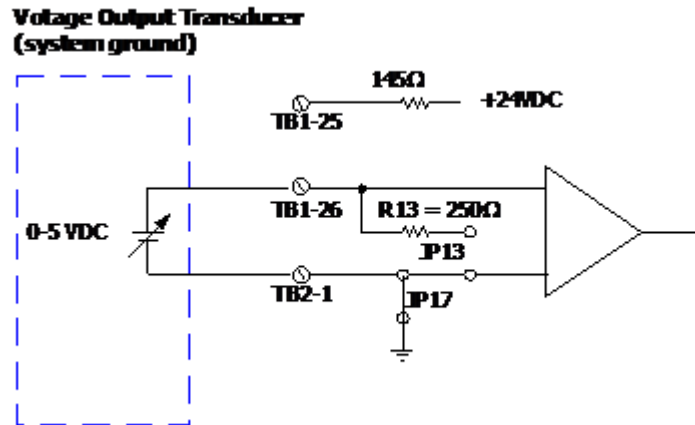

Slidewire

- Series C does not support Slidewire.

Range spool damage and wire shorting

Jumpers JP1 through JP16 are also used to overcome a damaged range spool (250 ohm dropping resistor).

A range spool can be damaged by being directly connected across a 24V for an extended period, such as, taking an even numbered terminal from TB1 to 24V. It can be removed from the circuit by clipping the corresponding jumper. You can continue to use the channel by providing a discrete (axial lead) 250 ohm resistor.

Example: using channel 5 and overcoming a damaged spool

1. One lead of the resistor connects to the even numbered screw on TB1 associated with that channel.
(i.e. screw $N = 2$ times channel M , so screw 10 is for channel 5).
2. The other lead of the resistor connects to Series C ground, which can probably be found on any of the TB2 screw positions (assuming the corresponding jumper JP17-20 is still installed).
If TB2 is already filled with wiring, 'doubling up' is permitted as long as the total wire dimension is less than the 14 AWG equivalent dimension.
3. Transmitter power is supplied in a non-incendive fashion through the odd-numbered terminals on TB1. This is done through a 145 ohm resistor inline with a Positive Temperature Coefficient (PTC) device that acts like a fuse (but never needs replacement).

Thus, these field terminals can be permanently shorted to ground without damage. This is an improvement over Process Manager due to the inclusion of the PTC device.

5.1.5 Analog Input wiring reference table

The following table summarizes the possible Analog Input wiring connections.

Table 21: Summary - Analog Input wiring connections

<i>Input style</i>	<i>Connection characteristics</i>
Standard 2-wire transmitter	<ul style="list-style-type: none"> • Can use any of the 16 channels. • No custom wiring required. • No jumper cuts required.
Standard self-powered transmitter	<ul style="list-style-type: none"> • Can use any of the 16 channels. • No custom wiring required. • No jumper cuts required.
Self-powered transmitter with loop power (system ground)	<ul style="list-style-type: none"> • Can use any of the 16 channels. • Custom wiring is required for channels 1-12: you must find a screw terminal at Series C ground for one leg of the transmitter. • No jumper cuts required
Self-powered transmitter with loop power (device ground)	<ul style="list-style-type: none"> • Cannot use channels 1-12. • Only use channels 13-16.
Self-powered 3-wire transmitter (system ground)	<ul style="list-style-type: none"> • Can use any of the 16 channels. • Custom wiring is required for channels 1-12: you must find a screw terminal at Series C ground for one leg of the transmitter. • No jumper cuts required
Voltage Input (system ground)	<ul style="list-style-type: none"> • Can use any of the 16 channels. • Custom wiring is required for channels 1-12: you must find a screw terminal at Series C ground for one leg of the transducer. • You must cut the jumper associated with the range spool.
Voltage Input (device ground)	<ul style="list-style-type: none"> • Cannot use channels 1-12. • Only use channels 13-16.
<p>Note: If multiple instruments need a ground reference the four positions of TB2 can serve as those ground points (assuming the JP17-JP20) jumpers are intact. If more than four grounding screws are needed then a custom wire from TB2 to a separate terminal block can allow for more grounding screw positions.</p>	

5.1.6 Allowable field wiring resistance - Analog Input module

The maximum allowable field wiring resistance between the transmitter and the IOTA connection terminal is dependent upon the voltage requirement of the transmitter. The formula for calculating the max wiring resistance for the Series C Analog Input is given by the following equation.

$$R_{max} = [(13.0 - V_{tx}) / (0.022)]$$

where: V_{tx} = Voltage required at the transmitter terminal

5.1.7 IOTA board and connections - Analog Input module

Series C Analog Input 6 inch, non-redundant IOTA and field wiring connection is displayed below:

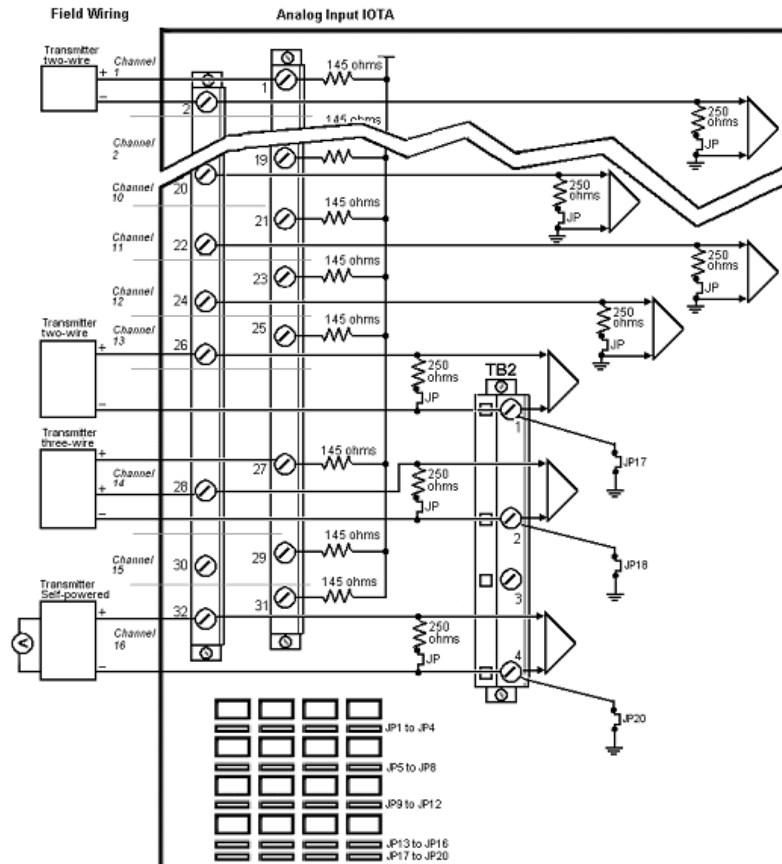

Figure 13: Series C Analog Input 6 inch, non-redundant IOTA and field wiring connections

Series C Analog Input 12 inch, redundant IOTA is displayed:

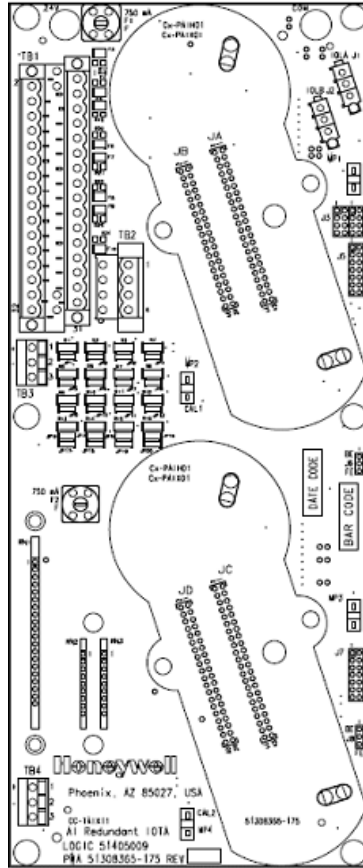

Figure 14: Series C Analog Input 12 inch, redundant IOTA

5.2 Analog Input non-HART/HARTIOTA Models Cx-TAIX51, Cx-TAIX61

This series C Analog Input IOTA board is represented by the following information and graphic.

To access the parts information for the:

- module
- IOTA
- terminal plug-in assembly, and
- fuses

associated with this board and module, refer to Analog Input in the Recommended Spare Parts section.

Series C HART/non-HART Analog Input 6 inch, non-redundant IOTA is displayed in the following figure.

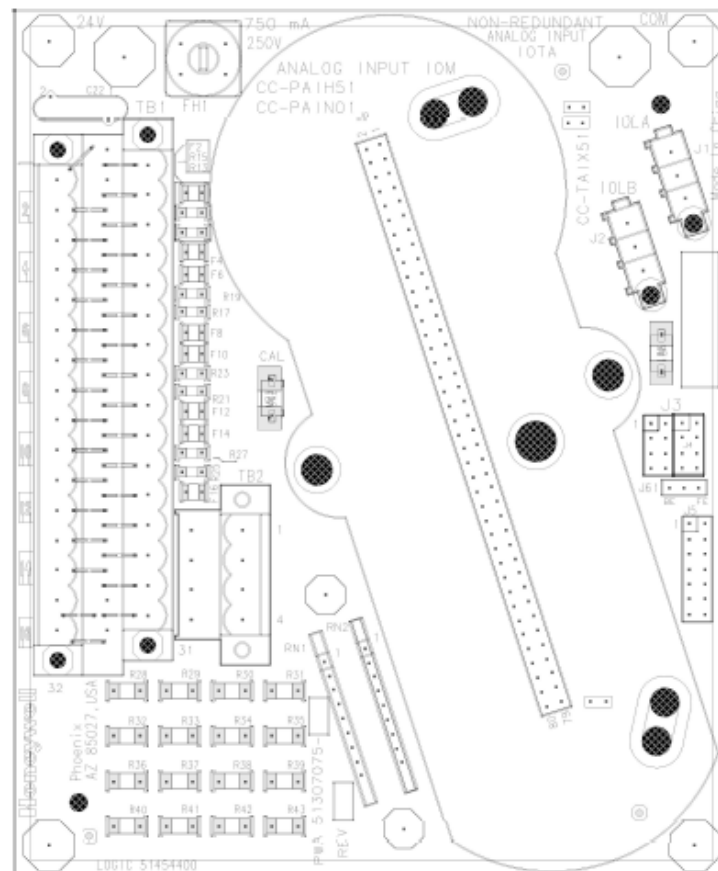

Figure 15: Series C HART/non-HART Analog Input 6 inch, non-redundant IOTA

Note: All I/O field terminations accept up to 14 gauge stranded wire.

To properly wire your module to the HART/non-HART Analog Input IOTA with terminal block 1 (TB1) and terminal block 2 (TB2), use the following table.

Table 22: AI 6 inch HART AI, non-redundant - terminal block 1

Terminal Block 1 (TB1)		
Channel	Return Screw	Power Screw(24V)
Channel 1	2	1
Channel 2	4	3

Terminal Block 1 (TB1)		
Channel	Return Screw	Power Screw(24V)
Channel 3	6	5
Channel 4	8	7
Channel 5	10	9
Channel 6	12	11
Channel 7	14	13
Channel 8	16	15
Channel 9	18	17
Channel 10	20	19
Channel 11	22	21
Channel 12	24	23
Channel 13	26	25
Channel 14	28	27
Channel 15	30	29
Channel 16	32	31

Table 23: AI 6 inch, HART/non-HART AI, non-redundant terminal block 2

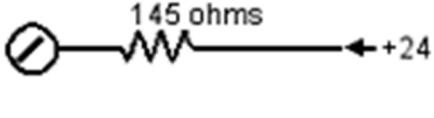
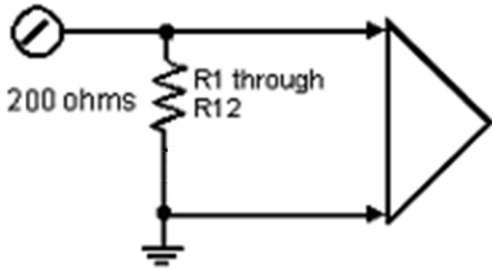
Channels	Signal screw
For channels 1 through 16	<p>Channels 1 through 16</p> <p>TB1 pin 1, 3, 5, 7, 9, 11, 13, 15, 17, 19, 21, 23, 25, 27, 29, 31</p>  <p>TB1 pin 2, 4, 6, 8, 10, 12, 14, 16, 18, 20, 22, 24, 26, 28, 30, 32</p> 

5.2.1 Field wiring and module protection - Analog Input HART module

Individual field wiring is protected by an internal protection circuit permitting.

- Short circuit protection of input for field short circuits. Protection suitable for Division 2 non-incendive / Zone 2 non-arcing.
- Each signal can be shorted in the field with no damage to module or board. Other channels on the same IOM will not be affected.

5.2.2 Two-wire transmitter wiring - Analog Input HART module

The AI IOM/IOTA is optimized for use with classic two-wire transmitters. All 16 channels can accept inputs from two-wire transmitters without any special wiring or jumper options.

5.2.3 Standard and self-powered two-wire transmitter wiring - Analog Input HART module

The HART/non-HART AI IOM/IOTA is optimized for use with classic two-wire transmitters. All 16 channels can accept inputs from two-wire transmitters. It is recommended to use channels 13 through 16, since these channels have a dedicated ground screw (although it is possible to use channels 1 through 12).

Following figure illustrates an example jumper configuration for channel 1 of non-redundant 9 inch IOTA.

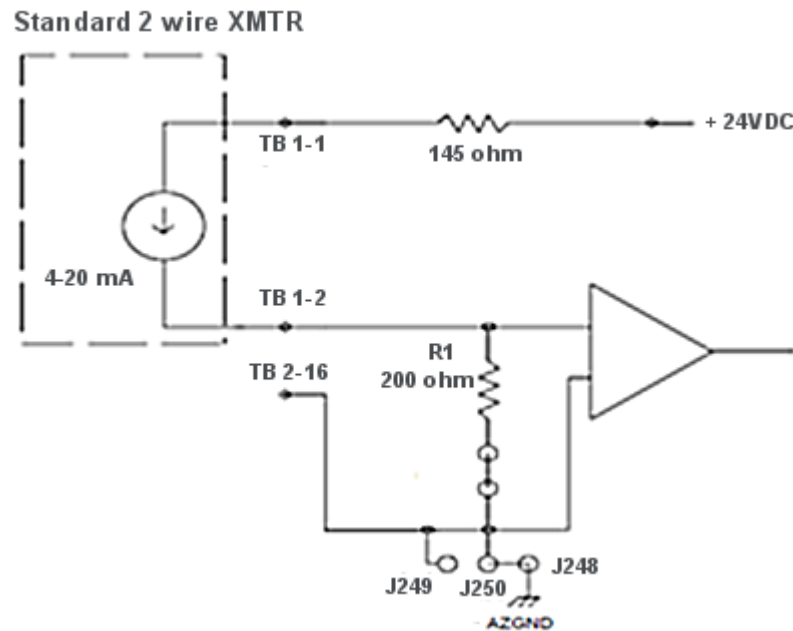

Figure 16: Non-redundant Analog Input 6 inch, standard 2-wire transmitter wiring

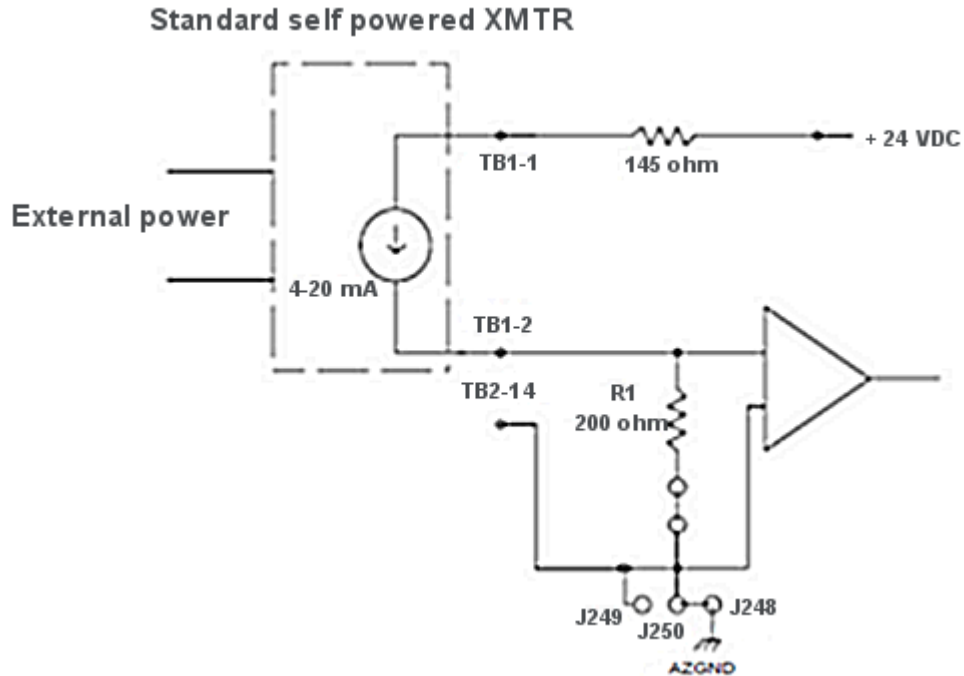

Figure 17: Non-redundant Analog Input 6 inch, self-powered 2-wire transmitter wiring

5.2.4 Self-powered 3-wire transmitter (system ground) - Analog Input HART module

It is recommended to use channels 13 through 16, since these channels have 3 screws per channel (although it is possible to use channels 1 through 12).

For the following example:

- Channel 13 is used
- The three wires are terminated to TB1-25, TB1-26 and TB2-1

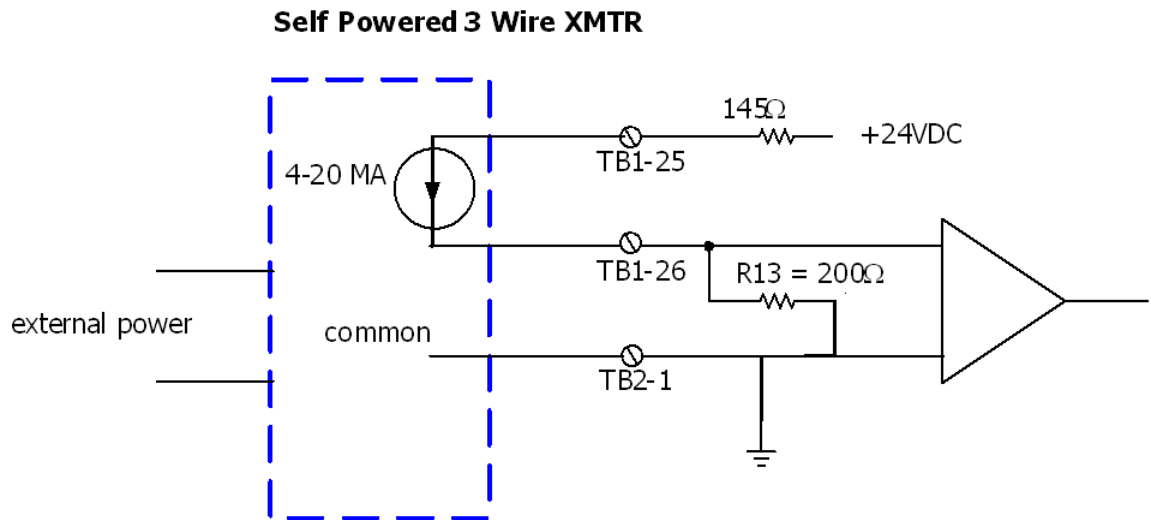

Note: TB1: This is done through a 145 ohm resistor inline with a Positive Temperature Coefficient (PTC) device that acts like a fuse (but never needs replacement). Thus, these field terminals can be permanently

shorted to ground without damage. This is an improvement over Process Manager due to the inclusion of the PTC device.

5.2.5 Analog Input HART module wiring reference table

The following table summarizes the possible Analog Input wiring connections.

Table 24: Summary - Analog Input wiring connections

Input style	Connection characteristics
Standard 2-wire transmitter	<ul style="list-style-type: none"> • Can use any of the 16 channels. • No custom wiring required.
Standard self-powered transmitter	<ul style="list-style-type: none"> • Can use any of the 16 channels. • No custom wiring required.
Self-powered transmitter with loop power(system ground)	<ul style="list-style-type: none"> • Can use any of the 16 channels. • Custom wiring is required for channels 1-12: you must find a screw terminal at ground for one leg of the transmitter.
Self-powered 3-wire transmitter (system ground)	<ul style="list-style-type: none"> • Can use any of the 16 channels. • Custom wiring is required for channels 1-12: you must find a screw terminal at ground for one leg of the transmitter.

5.2.6 Allowable field wiring resistance - Analog Input HART module

The maximum allowable field wiring resistance between the transmitter and the IOTA connection terminal is dependent upon the voltage requirement of the transmitter. The formula for calculating the max wiring resistance for the Analog Input is given by the following equation.

$$R_{max} = [(13.0 - V_{tx}) / (0.022)]$$

where: V_{tx} = Voltage required at the transmitter terminal

5.2.7 IOTA board and connections - Analog Input HART module

Series C Analog Input 6 inch, non-redundant IOTA and field wiring connection is displayed in the following image.

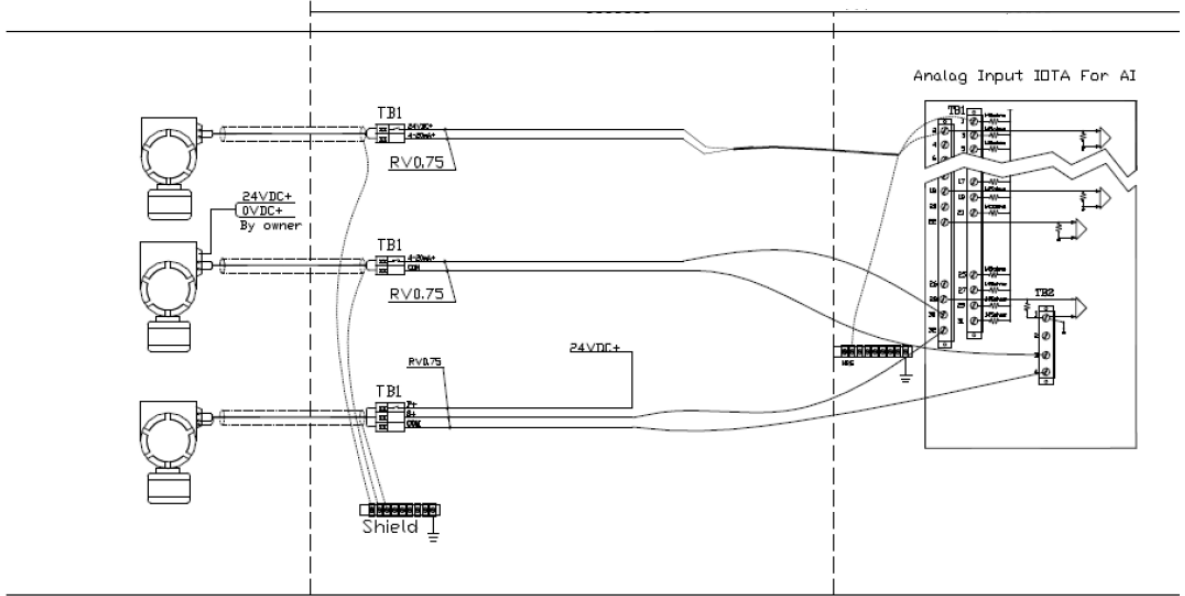

Figure 18: Series C Analog Input 6 inch, non-redundant IOTA and field wiring connection

The Series C Analog Input 12 inch, redundant IOTA is displayed in the following figure.

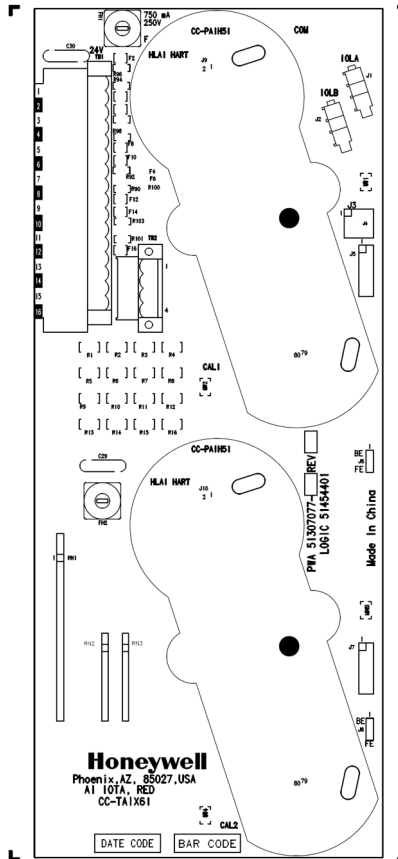

Figure 19: Series C HART/non-HART Analog Input 12 inch, redundant IOTA

5.3 Non-HART Analog Input IOTA (Models CC-TAIN01, CC-TAIN11)

This Series C Analog Input IOTA board is represented by the following information and graphic.

To access the parts information for the:

- module
- IOTA
- terminal plug-in assembly, and
- fuses

associated with this board and module, refer to Analog Input in the Recommended Spare Parts section.

Series C non-HART Analog Input 6 inch, non-redundant IOTA is displayed in the following figure.

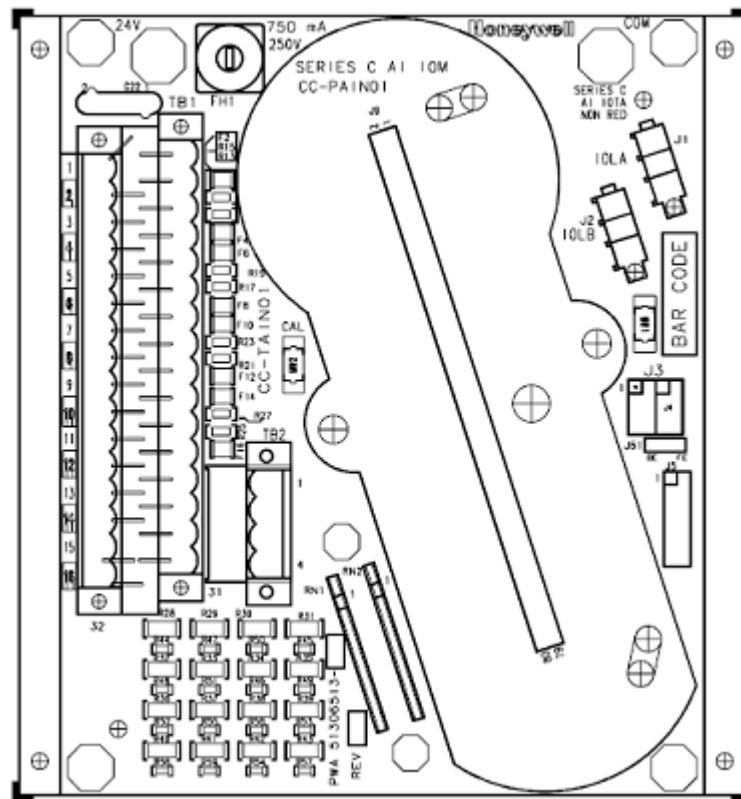

Figure 20: Series C non-HART Analog Input 6 inch, non-redundant IOTA

Note: All I/O field terminations accept up to 14 gauge stranded wire.

To properly wire your module to the Series C non-HART Analog Input IOTA with terminal block 1 (TB1) and terminal block 2 (TB2), use the following table.

Table 25: AI 6 inch, non-HART AI, non-redundant - terminal block 1

Terminal Block 1 (TB1)		
Channel	Return Screw	Power Screw(24V)
Channel 1	2	1
Channel 2	4	3
Channel 3	6	5

Terminal Block 1 (TB1)		
Channel	Return Screw	Power Screw(24V)
Channel 4	8	7
Channel 5	10	9
Channel 6	12	11
Channel 7	14	13
Channel 8	16	15
Channel 9	18	17
Channel 10	20	19
Channel 11	22	21
Channel 12	24	23
Channel 13	26	25
Channel 14	28	27
Channel 15	30	29
Channel 16	32	31

Table 26: AI 6 inch, non-HART AI, non-redundant terminal block 2

Channels	Signal screw
For channels 1 through 16	<p>Channels 1 through 16</p> <p>Channels 1 through 16</p> <p>TB1 pin 1, 3, 5, 7, 9, 11, 13, 15, 17, 19, 21, 23, 25, 27, 29, 31</p> <p>TB1 pin 2, 4, 6, 8, 10, 12, 14, 16, 18, 20, 22, 24, 26, 28, 30, 32</p>

5.3.1 Field wiring and module protection - non-HART Analog Input module

Individual field wiring is protected by an internal protection circuit permitting

- Short circuit protection of input for field short circuits. Protection suitable for Division 2 non-incendive / Zone 2 non-arcing.
- Each signal can be shorted in the field with no damage to module or board. Other channels on the same IOM will not be affected

5.3.2 Two-wire transmitter wiring - non-HART Analog Input module

The AI IOM/IOTA is optimized for use with classic two-wire transmitters. All 16 channels can accept inputs from two-wire transmitters without any special wiring or jumper options.

5.3.3 Standard and self-powered two-wire transmitter wiring - non-HART Analog Input module

The non-HART AI IOM/IOTA is optimized for use with classic two-wire transmitters. All 16 channels can accept inputs from two-wire transmitters. It is recommended to use channels 13 through 16, since these channels have a dedicated Series C ground screw (although it is possible to use channels 1 through 12).

Following figure illustrates an example jumper configuration for channel 1 of non-redundant 9 inch IOTA.

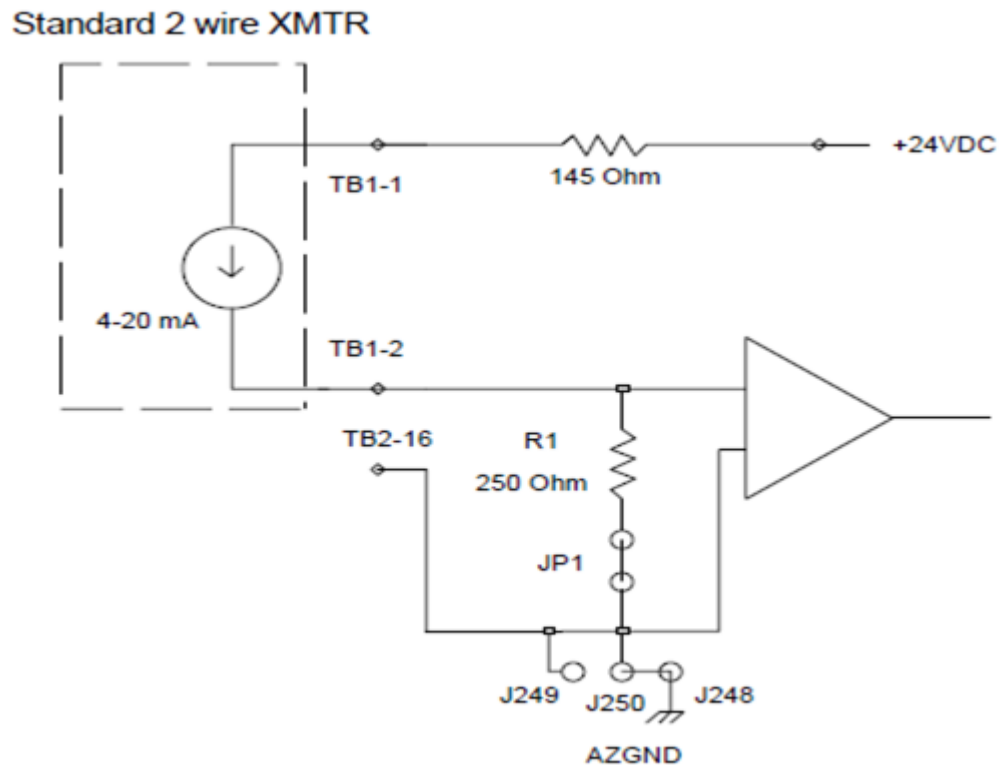

Figure 21: Non-redundant Analog Input 9 inch, standard 2-wire transmitter wiring

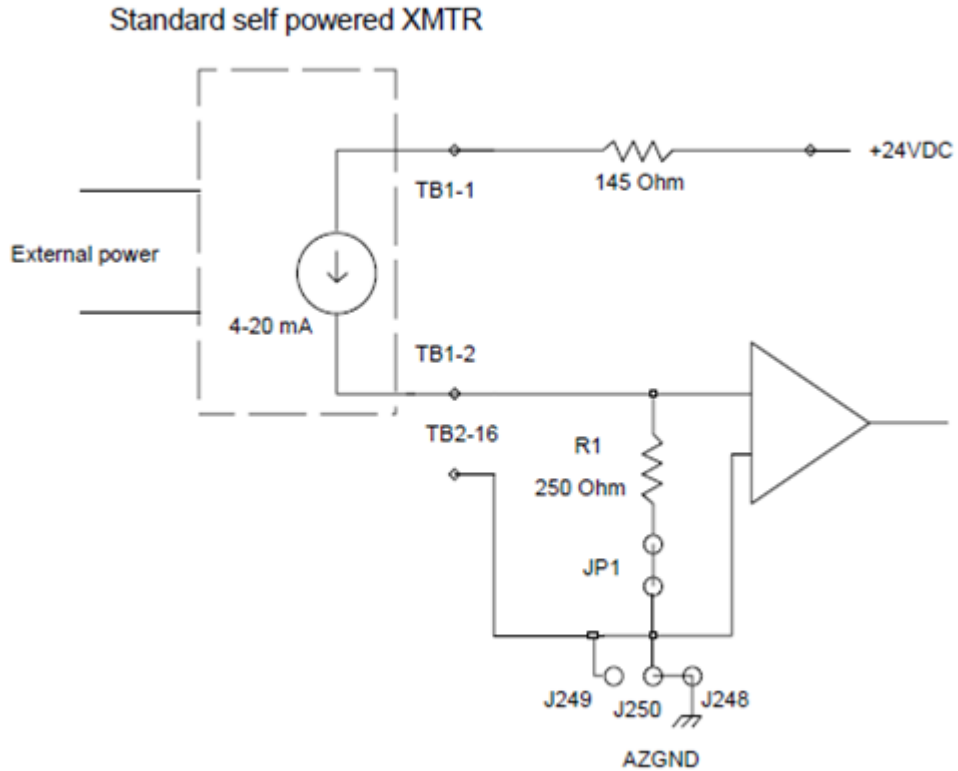

Figure 22: Non-redundant Analog Input 9 inch, self-powered 2-wire transmitter wiring

5.3.4 Self-powered 3-wire transmitter (system ground) - non-HART Analog Input module

It is recommended to use channels 13 through 16, since these channels have 3 screws per channel (although it is possible to use channels 1 through 12).

For the following example:

- Channel 13 is used
- The three wires are terminated to TB1-25, TB1-26 and TB2-1

Self Powered 3 Wire XMTR

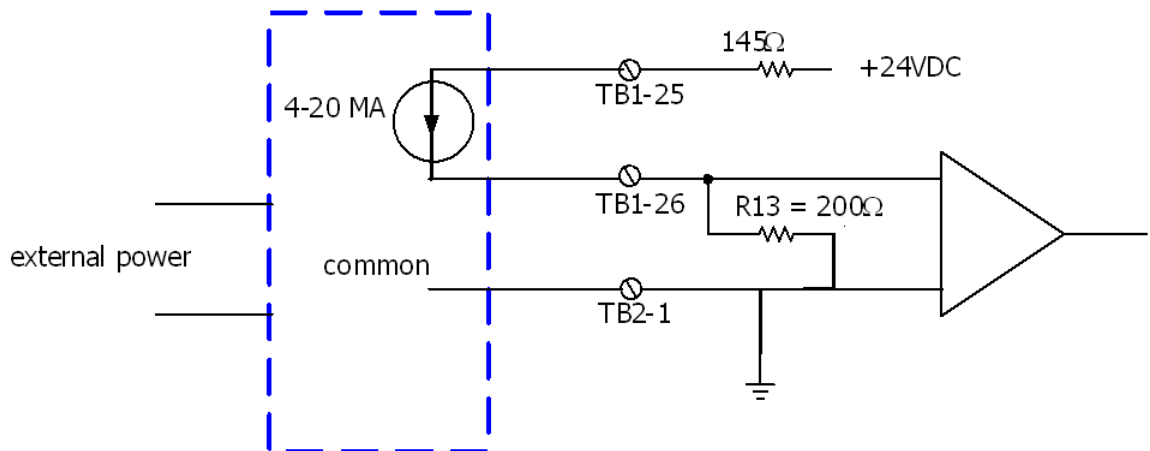

Note: TB1: This is done through a 145 ohm resistor inline with a Positive Temperature Coefficient (PTC) device that acts like a fuse (but never needs replacement). Thus, these field terminals can be permanently shorted to ground without damage. This is an improvement over Process Manager due to the inclusion of the PTC device.

5.3.5 Non-HART Analog Input module wiring reference table

The following table summarizes the possible Analog Input wiring connections.

Table 27: Summary - Analog Input wiring connections

Input style	Connection characteristics
Standard 2-wire transmitter	<ul style="list-style-type: none"> • Can use any of the 16 channels. • No custom wiring required.
Standard self-powered transmitter	<ul style="list-style-type: none"> • Can use any of the 16 channels. • No custom wiring required.
Self-powered transmitter with loop power(system ground)	<ul style="list-style-type: none"> • Can use any of the 16 channels. • Custom wiring is required for channels 1-12: you must find a screw terminal at Series C ground for one leg of the transmitter.
Self-powered 3-wire transmitter (system ground)	<ul style="list-style-type: none"> • Can use any of the 16 channels. • Custom wiring is required for channels 1-12: you must find a screw terminal at Series C ground for one leg of the transmitter.

5.3.6 Allowable field wiring resistance - non-HART Analog Input module

The maximum allowable field wiring resistance between the transmitter and the IOTA connection terminal is dependent upon the voltage requirement of the transmitter. The formula for calculating the max wiring resistance for the Series C Analog Input is given by the following equation.

$$R_{max} = [(13.0 - V_{tx}) / (0.022)]$$

where: V_{tx} = Voltage required at the transmitter terminal

5.3.7 IOTA board and connections - non-HART Analog Input module

Series C Analog Input 6 inch, non-redundant IOTA and field wiring connection is displayed in the following image.

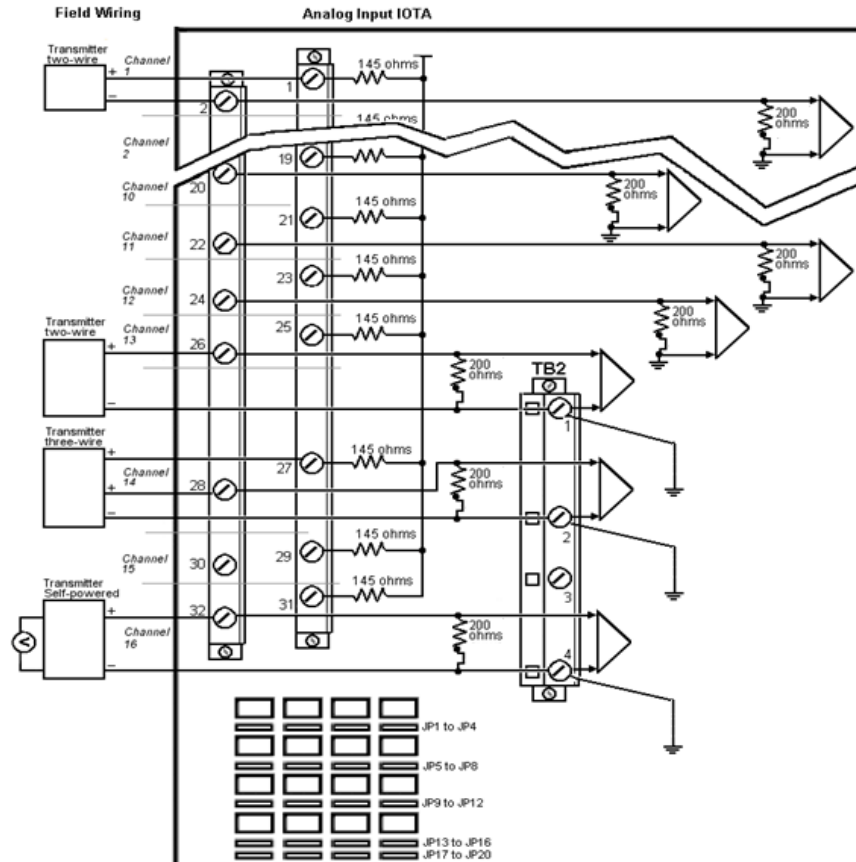

The Series C Analog Input 12 inch, redundant IOTA is displayed in the following figure.

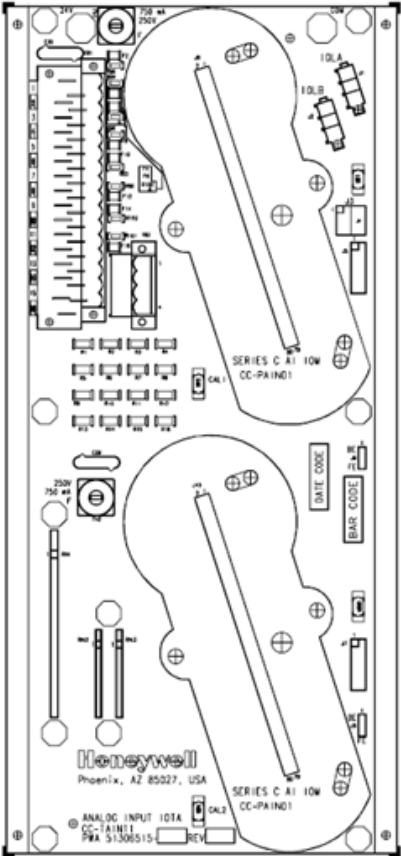

Figure 23: Series C non-HART Analog Input 12 inch, redundant IOTA

5.4 Differential Analog input IOTA (Models CC-TAID01 and CC-TAID11)

The Series C Analog Input 6 inch, 9 inch, and 12 inch modules supports all 16 channels for differential configuration. These channels can be configured to support different inputs such as 4-20mA, 1-5V, and 0-5V. All I/O field terminations of this IOTA is designed to accept up to 14 gauge stranded wire.

Note:

- These differential analog input modules are configured for differential configuration by default.
- The channels of these modules can be used for any configuration. that is, single-ended or differential configuration

5.4.1 Compatible IOTA models for differential analog input and output channels

IOM model number	IOM Block Name	Description	Compatible IOTA model number
CC-PAIH02	AI-HART	Differential/Single-ended Analog Input. It supports 16 channels and following inputs. <ul style="list-style-type: none"> • 4-20mA • 1-5V • 0-5V 	CC-TAID01 - Non-redundant CC-TAID11 - Redundant CC-TAIX01 - Non-redundant CC-TAIX11 - Redundant CC-GAIX11 - GI-IS-Non-Redundant CC-GAIX21 - GI-IS-Redundant
CC-PAIX02	AI	Differential/Single-ended Analog Input without HART functionality. It supports 16 channels and following inputs. <ul style="list-style-type: none"> • 4-20mA • 1-5V • 0-5V 	CC-TAID01 - Non-redundant CC-TAID11 - Redundant CC-TAIX01 - Non-redundant CC-TAIX11 - Redundant CC-GAIX11 - GI-IS-Non-Redundant CC-GAIX21 - GI-IS-Redundant
CC-PAIN01	AI-HL	Non-HART Analog Input module It supports 16 channels.	CC-TAIN01 (AI non-redundant; IOTA - 6') CC-TAIN11 (AI redundant; IOTA - 12')
CC-PAON01	AO	Non-HART Analog Output module It supports 16 channels.	CC-TAON01 (AO, non-redundant; IOTA - 6') CC-TAON11 (AO, redundant; IOTA - 12')

5.4.2 Standard and self-powered two-wire transmitter wiring - Differential Analog input module

The differential AI IOM/IOTA is optimized for use with classic two-wire transmitters. All 16 channels can accept inputs from two-wire transmitters. Note that, by default, the jumper settings must be changed to 'single-

ended configuration' as referred in the *Series C Differential Analog Input 9 inch – terminal block 2* table and the *Series C Differential Analog Input 12 inch – terminal block 2* table.

Following figure illustrates an example jumper configuration for channel 1 of non-redundant 9 inch IOTA.

Standard 2 wire XMTR

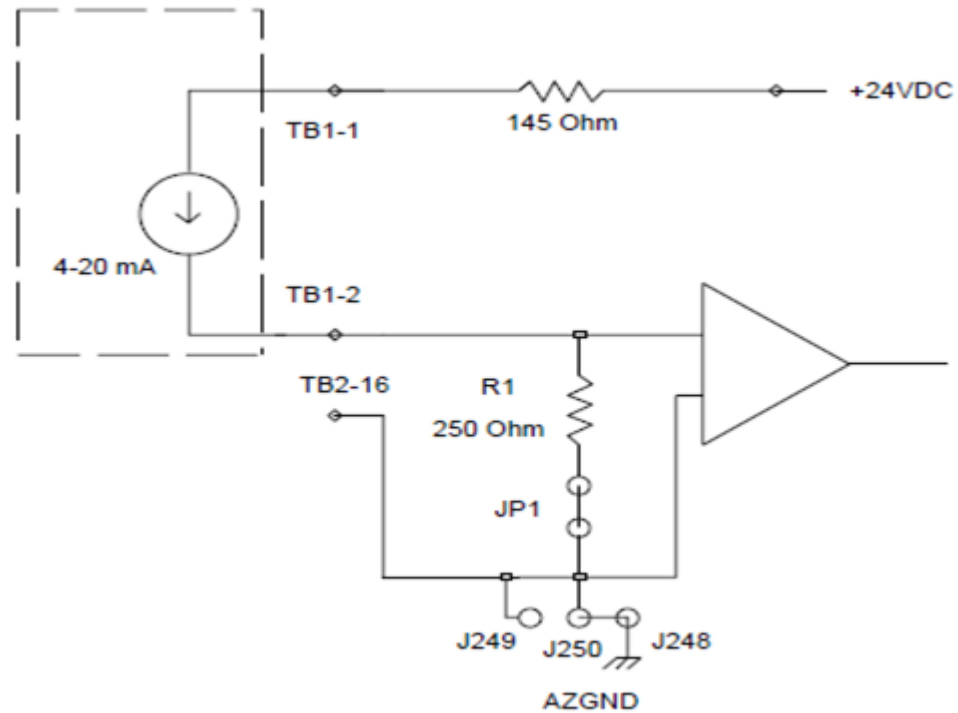

Figure 24: Non-redundant Analog Input 9 inch, standard 2-wire transmitter wiring

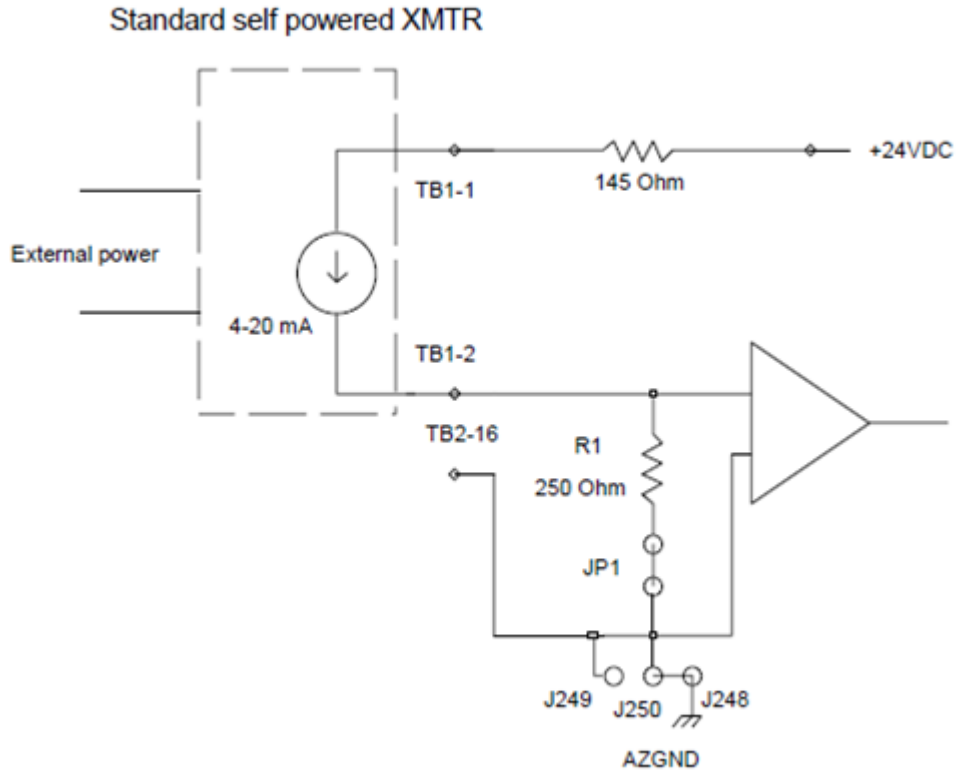

Figure 25: Non-redundant Analog Input 9 inch, self-powered 2-wire transmitter wiring

5.4.3 Custom wiring - Differential Analog input module

! Attention

- For differential HART transmitter, you can use only channel number 13 to 16. For non-HART differential transmitter, you can use all 16 channels in both differential mode and single-ended mode.

Custom wiring scenarios are explained in the following table.

Table 28: Custom wiring to support differential Analog Input

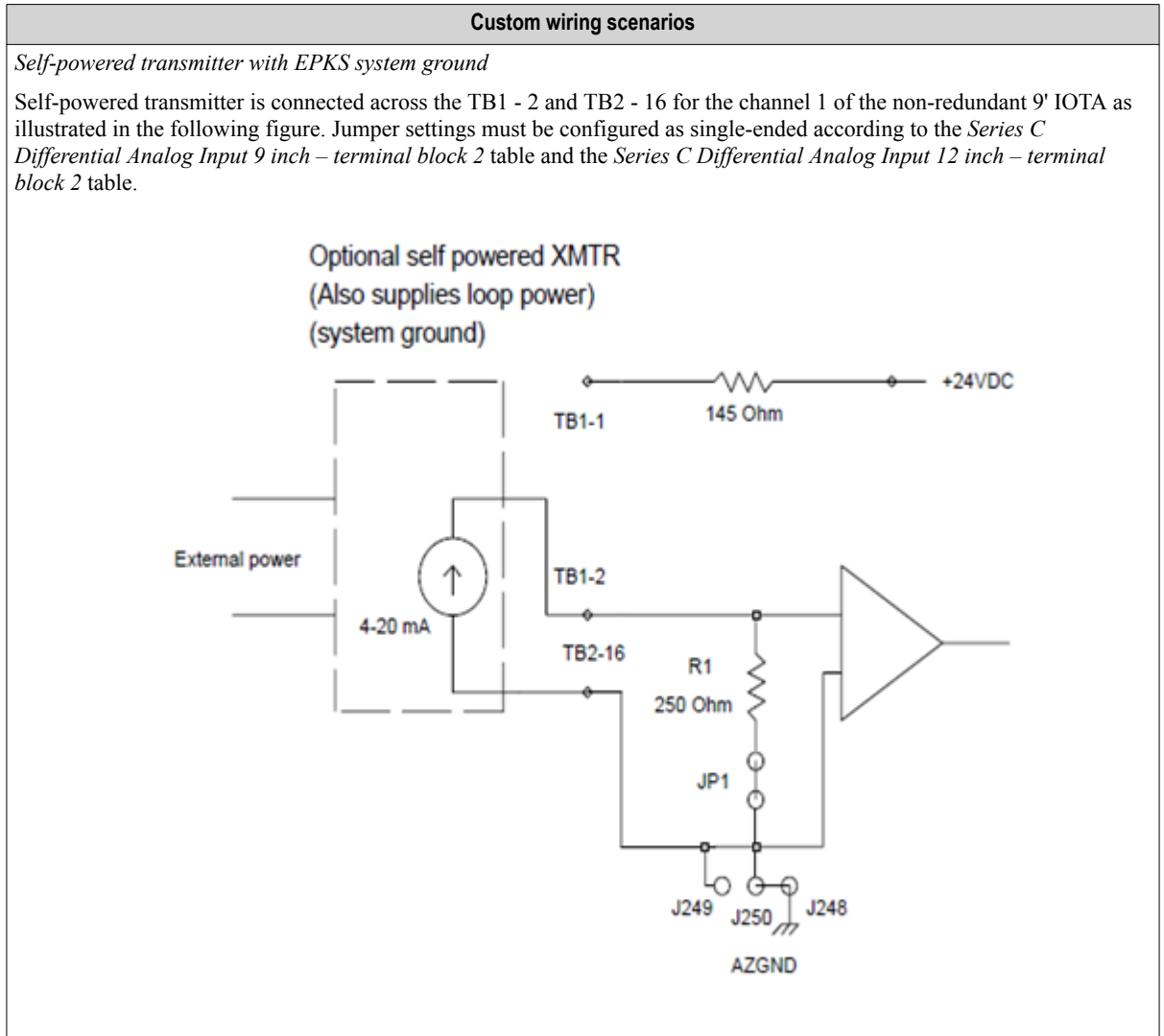

Custom wiring scenarios

Self-powered transmitter with device grounded

Self-powered transmitter is connected across the TB1 - 2 and TB2 - 16 for the channel 1 of the non-redundant 9' IOTA as illustrated in the following figure. Jumper settings must be configured for differential configuration according to the *Series C Differential Analog Input 9 inch – terminal block 2* table and the *Series C Differential Analog Input 12 inch – terminal block 2* table.

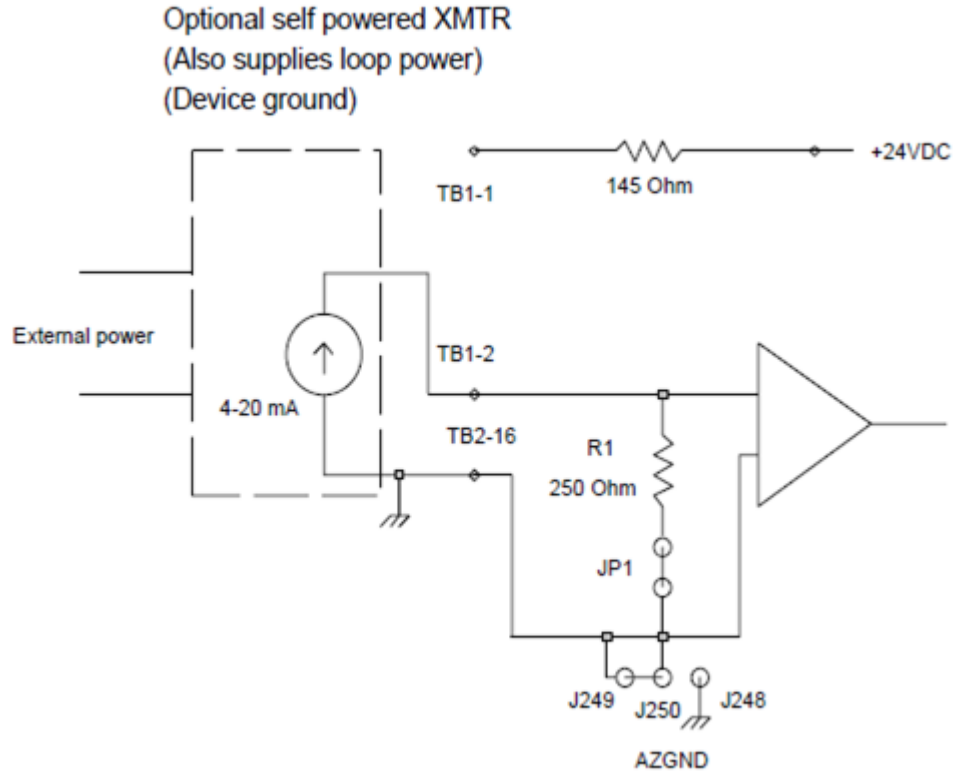

Custom wiring scenarios

Self-powered 3-wire transmitter (system ground)

Self-powered transmitter is connected across the TB1 - 1 and TB2 - 2 when the common terminal is terminated at TB2 - 16. Jumper settings must be configured as single-ended according to the *Series C Differential Analog Input 9 inch – terminal block 2* table and the *Series C Differential Analog Input 12 inch – terminal block 2* table.

Standard self powered 3 wire XMTR

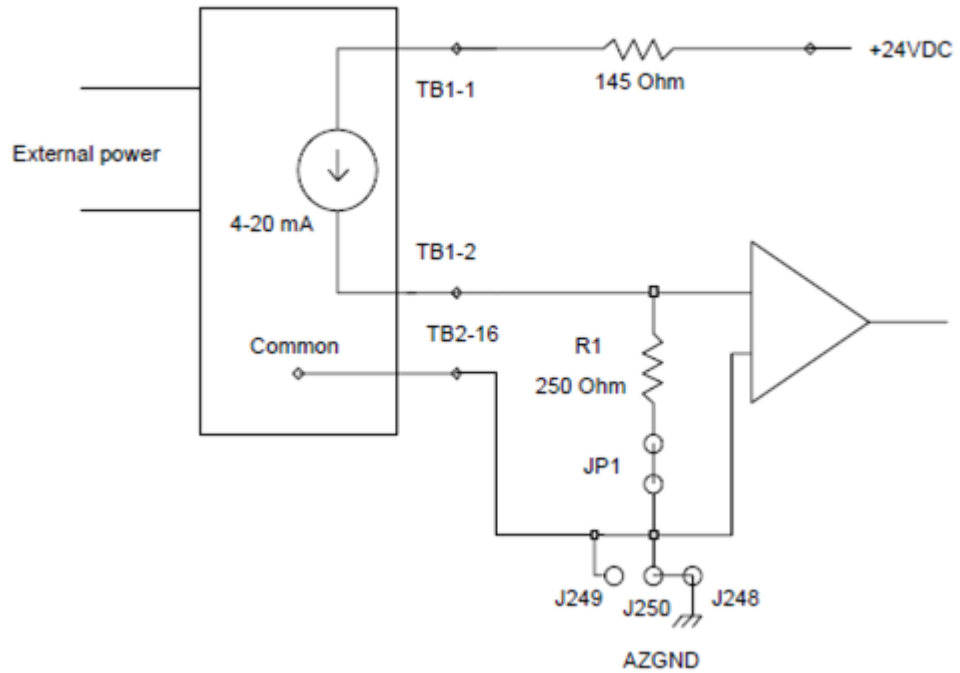

Custom wiring scenarios

Voltage input (System ground)

Voltage output transducer is connected across TB1-2 and TB2-16 as illustrated in the following figure. To use voltage output transducer, 250 Ω spool resistor must be disconnected by cutting the jumper (example, JP1). Jumper settings must be configured as single-ended according to the *Series C Differential Analog Input 9 inch – terminal block 2* table and the *Series C Differential Analog Input 12 inch – terminal block 2* table.

Voltage output Transducer (system ground)

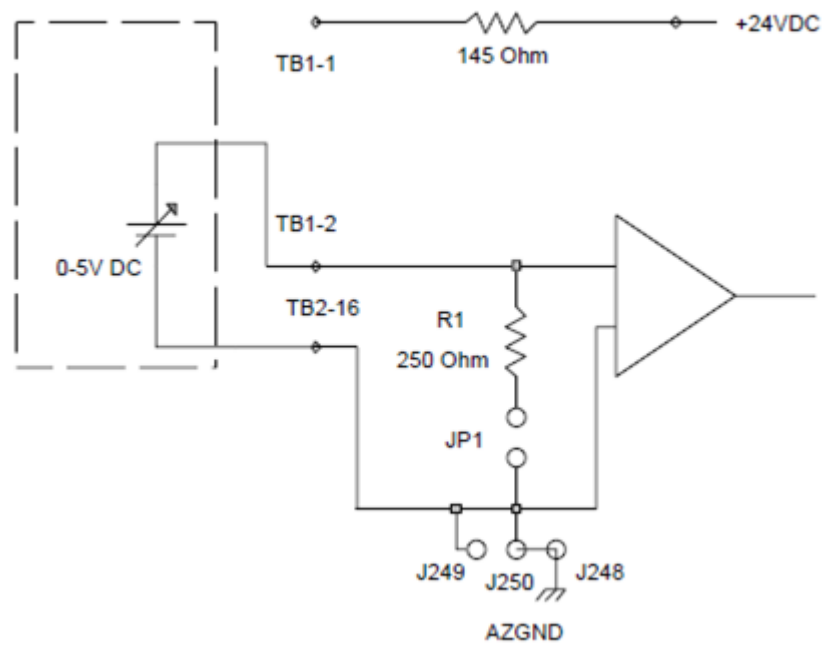

Note: You must plan cautiously when you cut the JP1 to JP16 jumpers as they are non-repairable. That is, once these jumpers are cut, you cannot short these jumpers.

Custom wiring scenarios

Voltage input (Device ground)

Voltage output transducer is connected across TB1-2 and TB2-16 as illustrated in the following figure. To use voltage output transducer, 250 Ω spool resistor must be disconnected by cutting the jumper (example, JP1). Jumper settings must be configured for differential configuration according to the *Series C Differential Analog Input 9 inch – terminal block 2* table and the *Series C Differential Analog Input 12 inch – terminal block 2* table.

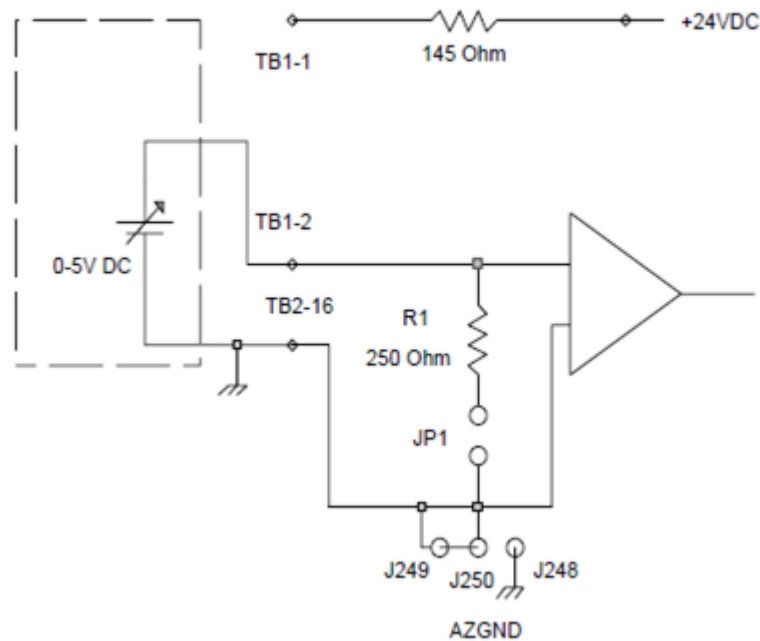
Voltage output Transducer
(Device ground)

Note: You must plan cautiously when you cut the JP1 to JP16 jumpers as they are non-repairable. That is, once these jumpers are cut, you cannot short these jumpers.

Slide Wire: Series C does not support Slidewire.

5.4.4 Jumper configuration for differential configuration - Differential Analog input module

Jumper configuration for the non-redundant differential AI channel is illustrated in the following figure. Each channel is associated with 250 Ω 'range spool' or 'dropping resistor' for sources that deliver 4-20mA. In addition, one jumper and three jumper pins are provided for each channel.

Example: channel 1 consists of JP1, J248, and J249.

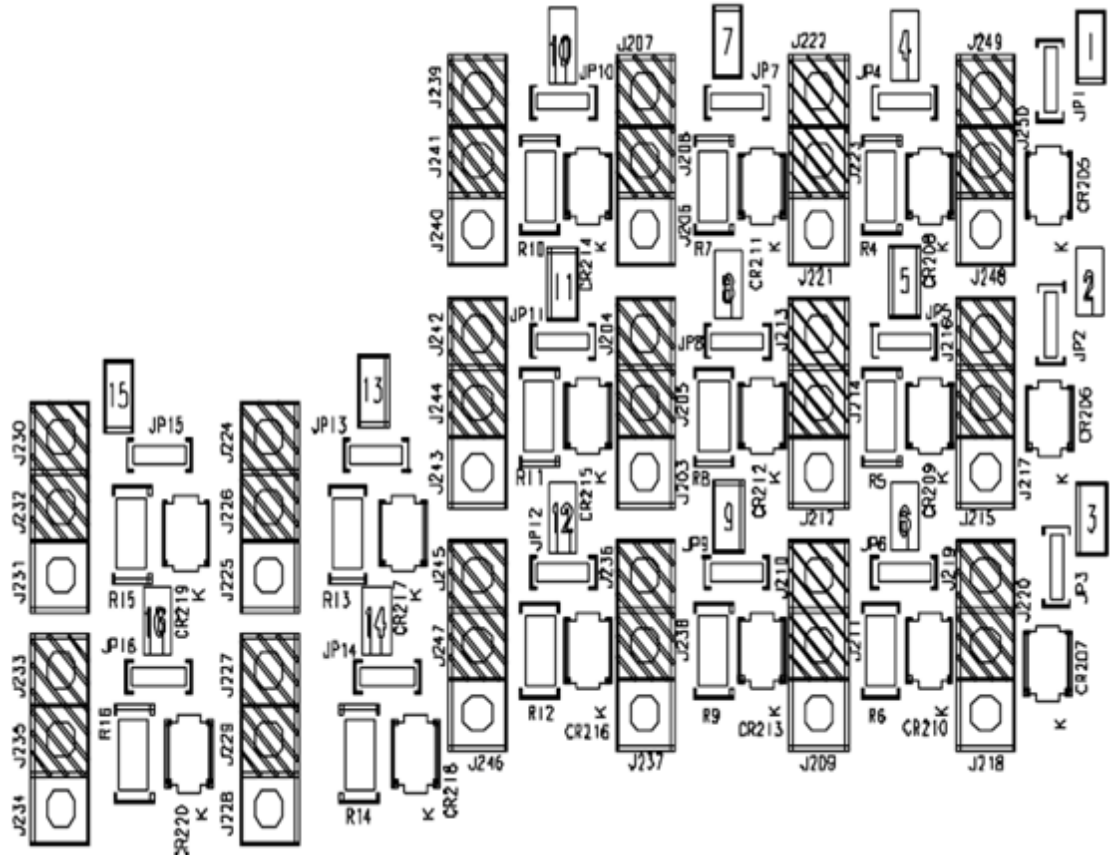

Figure 26: Series C differential non-redundant Analog Input 9 inch, jumper configuration

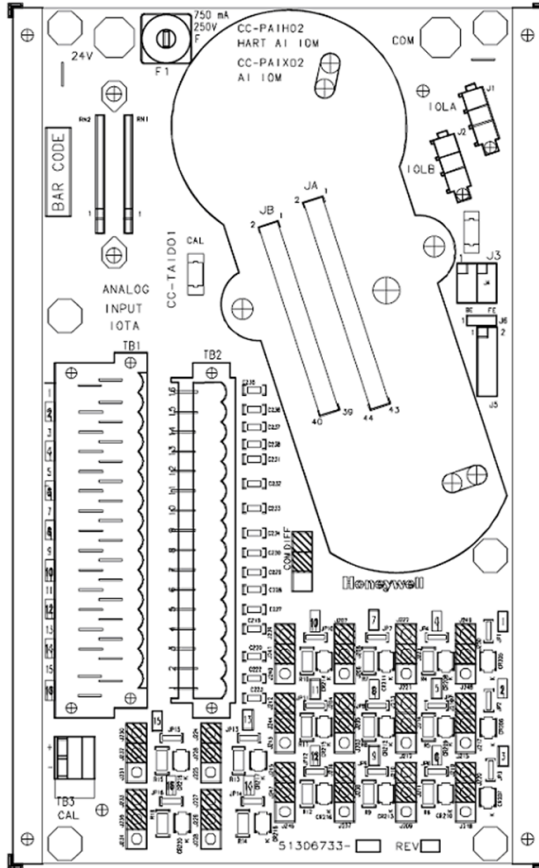

Figure 28: Series C Differential Analog Input 9 inch, non-redundant IOTA

To properly wire your module to the Series C Analog Input IOTA for differential configuration with terminal block 1 (TB1) and terminal block 2 (TB2), use the following table.

Table 29: Series C Differential Analog Input 9 and 12 inch - terminal block 1

Terminal Block 1		
Channel	Return screw	Power screw
Channel 1	2	1
Channel 2	4	3
Channel 3	6	5
Channel 4	8	7
Channel 5	10	9
Channel 6	12	11
Channel 7	14	13
Channel 8	16	15
Channel 9	18	17
Channel 10	20	19
Channel 11	22	21
Channel 12	24	23
Channel 13	26	25

Terminal Block 1		
Channel	Return screw	Power screw
Channel 14	28	27
Channel 15	30	29
Channel 16	32	31

Attention

- Three pin jumper labels are different for 9' and 12' IOTAs.
- All channels available in these IOTAs are configured for differential mode by default. If a shorting jumper is not present, that channel is configured in differential mode. If you want to modify the configuration from differential mode to single ended mode, refer to these to short the pair of jumpers.

Table 30: Series C Differential Analog Input 9 inch - terminal block 2

Terminal Block 2			
CC-TAID01 IOTA			
If TB2 screw is...	Then, the channel is...	And the pair of jumper to be short for differential configuration	And the pair of jumper to be short for single ended configuration
16	16	J233 - J235	J234 - J235
15	15	J230 - J232	J231 - J232
14	14	J227 - J229	J228 - J229
13	13	J224 - J226	J225 - J226
12	12	J245 - J247	J246 - J247
11	11	J242 - J244	J243 - J244
10	10	J239 - J241	J240 - J241
9	9	J236 - J238	J237 - J238
8	8	J204 - J205	J203 - J205
7	7	J207 - 208	J206 - J208
6	6	J210 - J211	J209 - J211
5	5	J213 - J214	J212 - J214
4	4	J222 - J223	J221 - J223
3	3	J219 - J220	J218 - J220
2	2	J216 - J217	J215 - J217
1	1	J249 - J250	J248 - J250

Table 31: Series C Differential Analog Input 12 inch - terminal block 2

Terminal Block 2			
CC-TAID11 IOTA			
If TB2 screw is...	Then, the channel is...	And the pair of jumper to be short for differential configuration	And the pair of jumper to be short for single ended configuration
TB2-16	Channel 1	JP21 - JP23	JP22 - JP23
TB2-15	Channel 2	JP24 - JP26	JP25 - P26
TB2-14	Channel 3	JP51 - JP53	JP52 - JP53
TB2-13	Channel 4	JP54 - JP56	JP55 - JP56

Terminal Block 2			
CC-TAID11 IOTA			
If TB2 screw is...	Then, the channel is...	And the pair of jumper to be short for differential configuration	And the pair of jumper to be short for single ended configuration
TB2-12	Channel 5	JP57 - JP59	JP58 - JP59
TB2-11	Channel 6	JP60, JP61 ,JP66	JP61 - JP66
TB2-10	Channel 7	JP62, JP63,JP67	JP63 - JP67
TB2-9	Channel 8	JP64, JP65, JP68	JP65 - JP68
TB2-8	Channel 9	JP27 - JP29	JP28 - JP29
TB2-7	Channel 10	JP30 - JP32	JP31 - JP32
TB2-6	Channel 11	JP33 - JP35	JP34 - JP35
TB2-5	Channel 12	JP36 - JP38	JP37 - JP38
TB2-4	Channel 13	JP39 - JP41	JP40 - JP41
TB2-3	Channel 14	JP42 - JP44	JP43 - JP44
TB2-2	Channel 15	JP45 - JP47	JP46 - JP47
TB2-1	Channel 16	JP48 - JP50	JP49 - JP50

The Series C Analog Input 12 inch, non-redundant IOTA is displayed in the following figure.

Table 32: Series C Differential Analog Input 12 inch, redundant IOTA

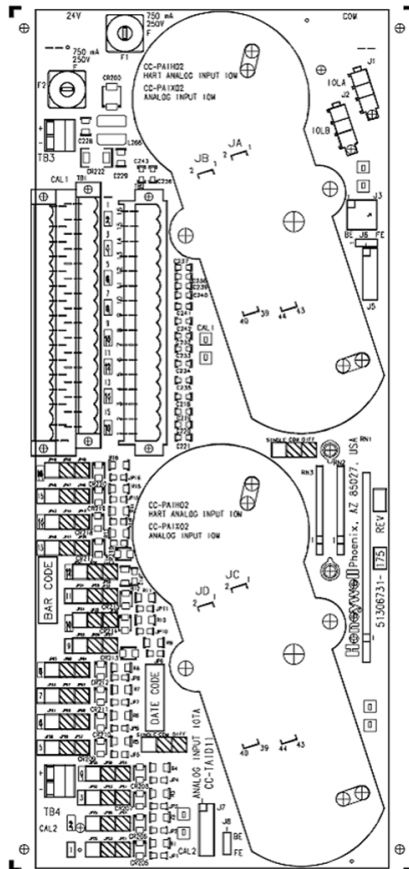

5.5 Analog Output IOTA Models CC-TAOX01, CC-TAOX11, CC-TAON01 and CC-TAON11

This Series C Analog Output IOTA board is represented by the following information and graphics.

To access the parts information for the:

- module
- IOTA
- terminal plug-in assembly, and
- fuses

associated with this board and module, refer to Analog Output in the Recommended Spare Parts section.

5.5.1 Field wiring and module protection - Analog Output module

The Analog Output module provides an output current range of 0mA, and 2.9 mA through 21.1 mA based on the requested Analog Output by the Series C controller. The output current including the HART modulated signal, does not exceed 22.5mA.

- Short circuit protection of field short circuits. Protection suitable for Division 2 non-incendive / Zone 2 non-arcing.
- Each field wiring pair can be shorted together without damage to the module or IOTA. Other channels in the same module(s) will not be affected.
- A +30 Vdc source can be continuously applied across the OUT+ to OUT- terminals of the IOTA without damage to either module(s) or IOTA (i.e. with the positive lead of the source connected to OUT+ and the negative lead connected to OUT-). To prevent damage to the IOTA surge protection diodes, the current must be limited to 500 mAdc if the source is applied in the reverse polarity (i.e. with the positive lead of the source attached to OUT-, negative lead attached to OUT+). This 500 mAdc restriction does not apply in the positive polarity case.

5.5.2 IOTA board and connections - Analog Output module

Series C Analog Output 6 inch, non-redundant IOTA is displayed.

Table 33: Series C Analog Output 6 inch, non-redundant IOTA

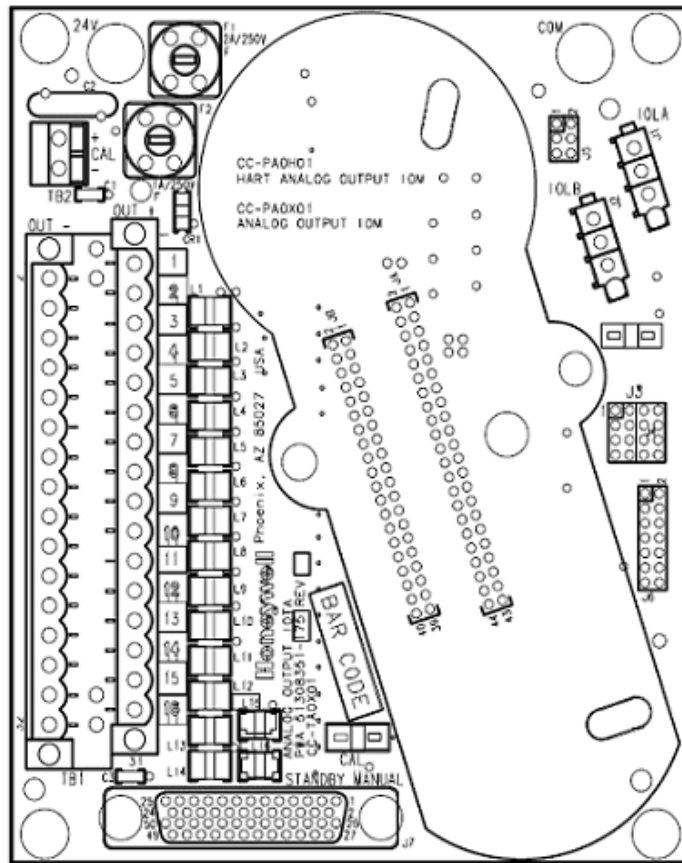

To properly wire your module to the Series C Analog Output IOTA board with terminal block 1 (TB1), use the following table.

Table 34: AO 6 inch, non-redundant - terminal block 1

Channel	Return screw (OUT -)	Signal screw (OUT +)
Channel 1	2	1
Channel 2	4	3
Channel 3	6	5
Channel 4	8	7
Channel 5	10	9
Channel 6	12	11
Channel 7	14	13
Channel 8	16	15
Channel 9	18	17
Channel 10	20	19
Channel 11	22	21
Channel 12	24	23

Channel	Return screw (OUT -)	Signal screw (OUT +)
Channel 13	26	25
Channel 14	28	27
Channel 15	30	29
Channel 16	32	31

Series C Analog Output 6 inch, non-redundant IOTA and field wiring connection

Table 35: Series C Analog Output 6 inch, non-redundant IOTA and field wiring connection

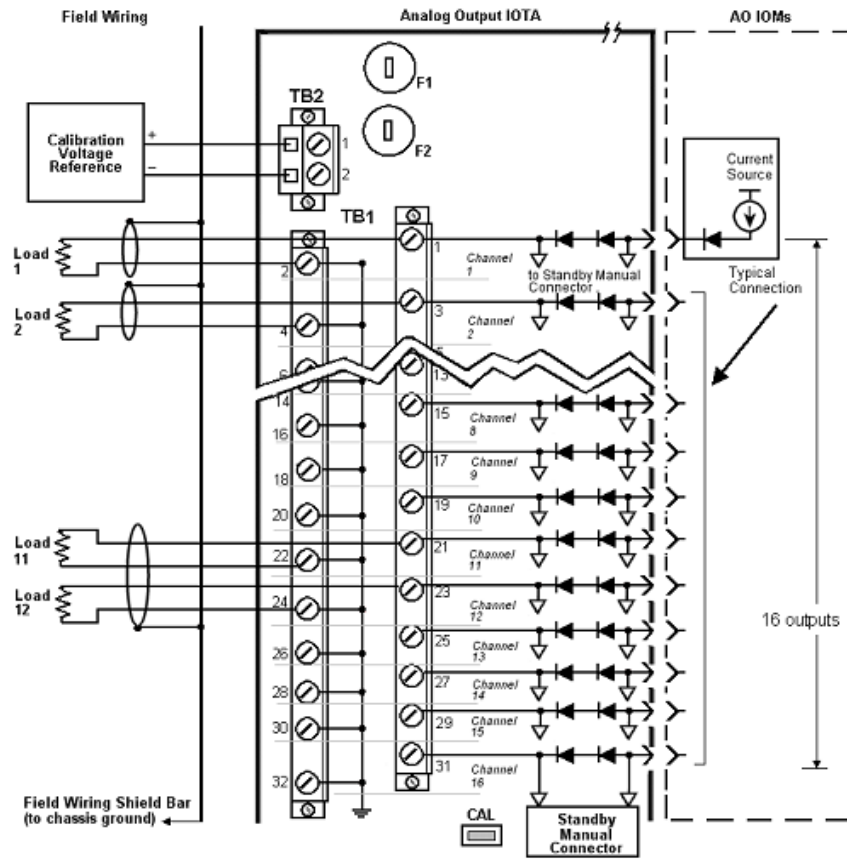

Series C Analog Output 12 inch, redundant IOTA is displayed:

Table 36: Series C Analog Output 12 inch, redundant IOTA

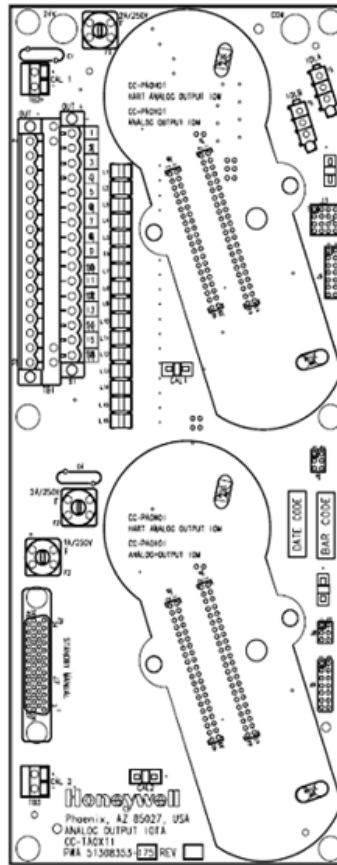

5.5.3 Non-HART Analog Output IOTA (Models CC-TAON01, CC-TAON11)

The Series C non-HART Analog Output 6 inch, non-redundant modules supports all 16 channels for single-ended configuration. All I/O field terminations of this IOTA is designed to accept up to 14 gauge stranded wire.

5.5.4 IOTA board and connections - non-HART Analog Output module

The Series C Analog Output 6 inch, non-redundant IOTA is displayed in the following figure.

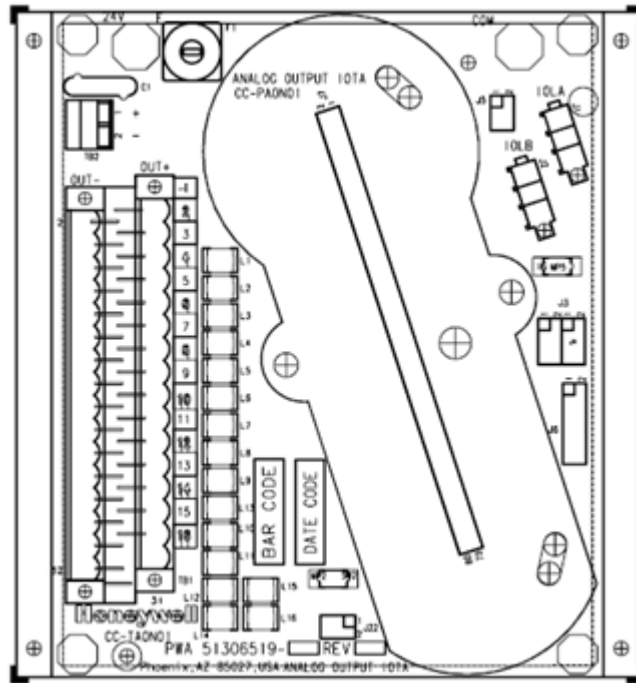

Figure 29: Series C non-HART Analog Output 6 inch, non-redundant IOTA

The Series C Analog Output 12 inch, redundant IOTA is displayed in the following figure.

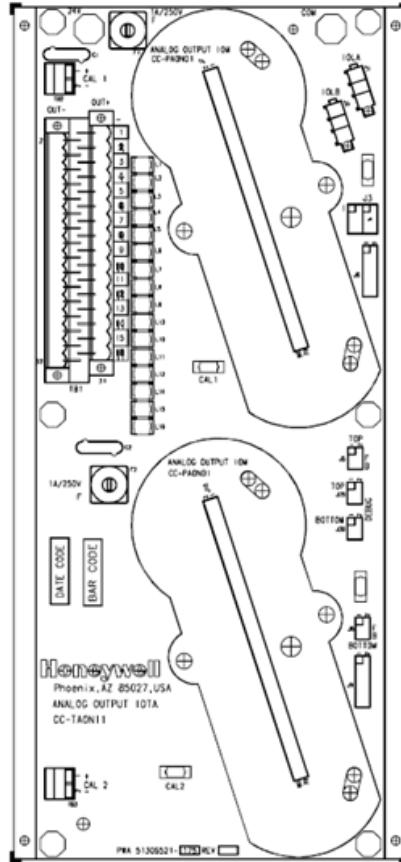

Figure 30: Series C non-HART Analog Input 12 inch, redundant IOTA

To properly wire your module to the Series C non-HART Analog Output IOTA with terminal block 1 (TB1) and terminal block 2 (TB2), use the following table.

Table 37: AO 6 inch, non-HART AO, non-redundant - terminal block 1

Terminal Block 1 (TB1)		
Channel	Return Screw (Negative)	Analog Output Screw (Positive)
Channel 1	2	1
Channel 2	4	3
Channel 3	6	5
Channel 4	8	7
Channel 5	10	9
Channel 6	12	11
Channel 7	14	13
Channel 8	16	15
Channel 9	18	17
Channel 10	20	19
Channel 11	22	21
Channel 12	24	23
Channel 13	26	25

Terminal Block 1 (TB1)		
Channel	Return Screw (Negative)	Analog Output Screw (Positive)
Channel 14	28	27
Channel 15	30	29
Channel 16	32	31
<p>Note:</p> <p>TB1: 32 pin connector - screw block</p> <ul style="list-style-type: none"> • 16 channels positive output terminals must be connected through upper-side of 32 pin connector. • 16 channels negative output terminals must be connected through lower-side of 32 pin connector. 		

The field wiring connection for Series C non-HART Analog Input 6 inch, non-redundant IOTA is identical to the Series C Analog Input 6 inch, non-redundant IOTA. For more information about the field wiring, refer to “IOTA board and connections - Analog Output module” on page 115.

5.6 Analog Output HART IOTA Models Cx-TAOX51, Cx-TAOX61

Note: Cx-TAOX51 and Cx-TAOX61 support only HART Modules.

The Analog Output IOTA board is represented by the following information and graphics.

To access the parts information for the:

- module
- IOTA
- terminal plug-in assembly, and
- fuses

associated with this board and module, refer to Analog Output in the Recommended Spare Parts section.

5.6.1 Field wiring and module protection - Analog Output HART module

The Analog Output module provides an output current range of 0mA, and 2.9 mA through 21.1 mA based on the requested Analog Output by the Series C controller. The output current including the HART modulated signal, does not exceed 22.5mA.

- Short circuit protection of field short circuits. Protection suitable for Division 2 non-incendive / Zone 2 non-arcing.
- Each field wiring pair can be shorted together without damage to the module or IOTA. Other channels in the same module(s) will not be affected.
- A +30 Vdc source can be continuously applied across the OUT+ to OUT- terminals of the IOTA without damage to either module(s) or IOTA (i.e. with the positive lead of the source connected to OUT+ and the negative lead connected to OUT-). To prevent damage to the IOTA surge protection diodes, the current must be limited to 500 mAdc if the source is applied in the reverse polarity (i.e. with the positive lead of the source attached to OUT-, negative lead attached to OUT+). This 500 mAdc restriction does not apply in the positive polarity case.

5.6.2 IOTA board and connections - Analog Output HART module

Series C Analog Output 6 inch, non-redundant IOTA is displayed.

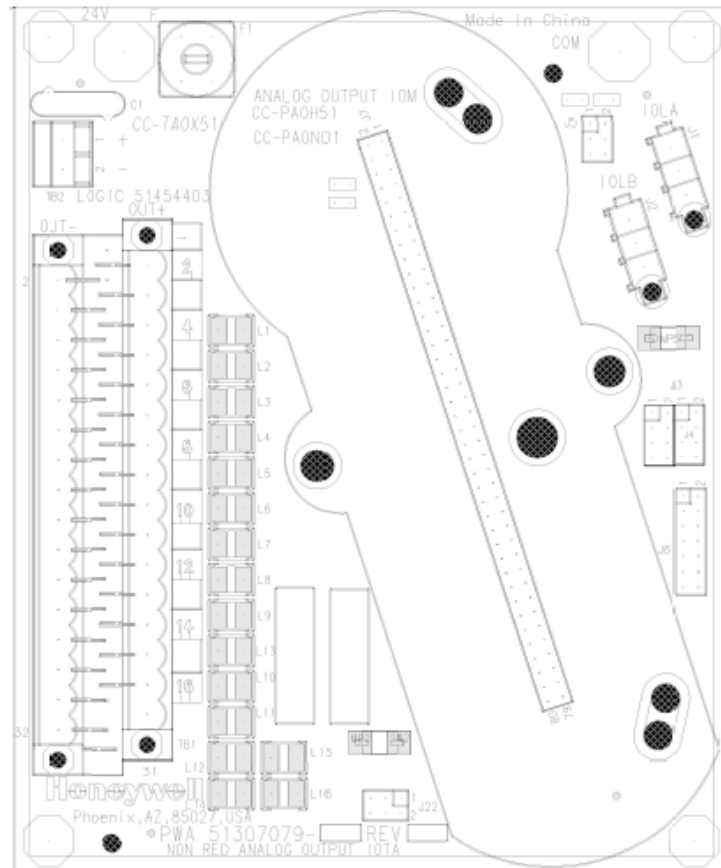

Figure 31: Series C Analog Output 6 inch, non-redundant IOTA

To wire your module to the Series C Analog Output IOTA board with terminal block 1 (TB1), use the following table.

Table 38: AO 6 inch, non-redundant - terminal block 1

Channel	Return screw (OUT -)	Signal screw (OUT +)
Channel 1	2	1
Channel 2	4	3
Channel 3	6	5
Channel 4	8	7
Channel 5	10	9
Channel 6	12	11
Channel 7	14	13
Channel 8	16	15
Channel 9	18	17
Channel 10	20	19
Channel 11	22	21
Channel 12	24	23
Channel 13	26	25

Channel	Return screw (OUT -)	Signal screw (OUT +)
Channel 14	28	27
Channel 15	30	29
Channel 16	32	31

Series C Analog Output 6 inch, non-redundant IOTA and field wiring connection

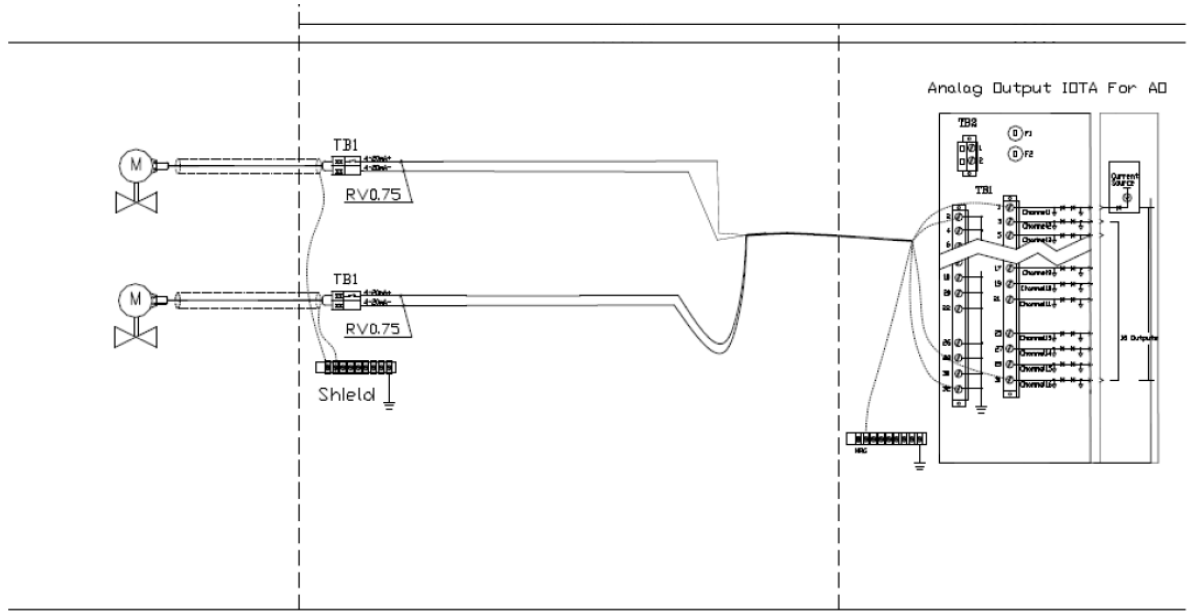

Figure 32: Series C Analog Output 6 inch, non-redundant IOTA and field wiring connection

Series C Analog Output 12 inch, redundant IOTA is displayed:

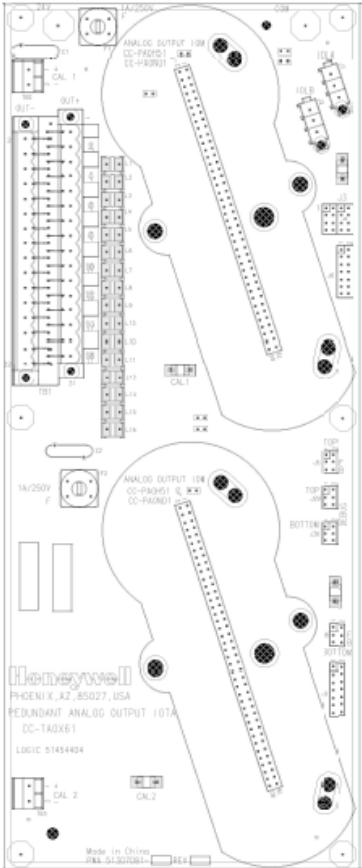

Figure 33: Series C Analog Output 12 inch, redundant IOTA

5.7 Low Level Analog Input Mux (LLMUX) IOTA Models CC-TAIM01

The Series C Low Level Mux IOTA board is represented by the following information and graphics.

To access the parts information for the:

- module
- IOTA
- connector block assembly, and
- fuses

associated with this board and module, refer to Low Level Analog Input in the Recommended Spare Parts section.

5.7.1 Field wiring and module protection - Low Level Analog Input Mux (LLMUX) module

The LLMUX module provides power and communications to up to four Low Level Mux FTAs. Each FTA is protected by a specific fuse. Additionally, a main fuse protects the module's power path to all FTAs.

The following applies to fusing for LLMUX:

Fuse	Functionality	Description
F1	Power to module electronics	FUSE, 1 Amp
F2	Switched power to all FTAs	Quick Blo, 5x20mm
F3	Power to FTA 1 only	FUSE, 0.25 Amp, Quick Blo, 5x20mm
F4	Power to FTA 2 only	
F5	Power to FTA 3 only	
F6	Power to FTA 4 only	

Fuses 1 and 2

- The primary purpose of the main electronics fuse (F1) is to protect the module electronics. The primary role of the main FTA fuse (F2) is to isolate the power path from the module electronics and prevent a short circuit in the FTA power path from impacting the entire system.

Fuses 3 through 6

- A simultaneous failure of multiple FTAs can blow the common FTA fuse.
- A short circuit on a power cable to an FTA or a short in an FTA will blow the IOTA fuse for that FTA, but not affect any of the other FTAs or their fuses.

5.7.2 IOTA board and connections - Low Level Analog Input Mux (LLMUX) module

Series C Low Level 6 inch, non-redundant IOTA is displayed.

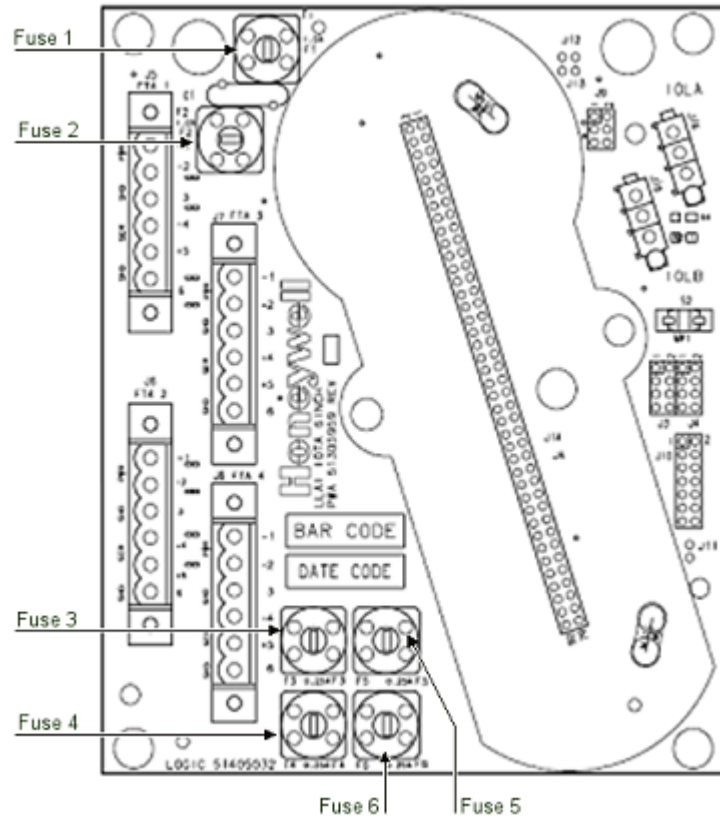

Figure 34: Series C Low Level 6 inch, non-redundant IOTA

To properly wire your module to the Series C Low Level Analog Input IOTA board with Field Termination Assembly 1 (FTA1) and 2 (FTA 2), use the following graphic and table.

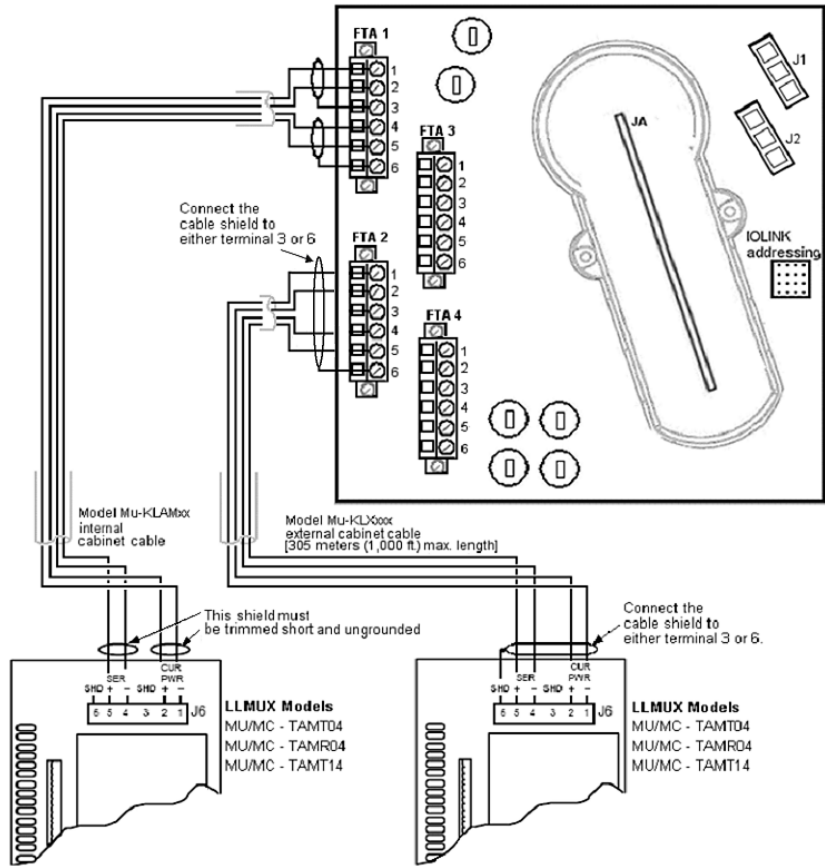

Figure 35: Series C Low Level Analog Input IOTA and field wiring connections

Table 39: LL MUX FTA connections

Field Termination Assembly (for FTA's 1, 2, 3, and 4)	
Terminal	Power screw
1 power	negative
2 power	positive
3 shield	n/a
4 serial	negative
5 serial	positive
6 shield	n/a

Table 40: LL MUX FTA jumper unit positions

Field Termination Assembly - jumper unit position	
FTA	Unit position
FTA 1	0
FTA 2	1
FTA 3	0

Field Termination Assembly - jumper unit position	
FTA	Unit position
FTA 4	1

5.8 Digital Input High Voltage IOTA Models CC-TDI110, CC-TDI120, CC-TDI220, CC-TDI230

The Series C Digital Input High Voltage IOTA board is represented by the following information and graphics.

To access the parts information for the:

- module
- IOTA
- terminal plug-in assembly, and
- fuses

associated with this board and module, refer to Digital Input - High Voltage in the Recommended Spare Parts section.

5.8.1 Field wiring and module protection - Digital Input High Voltage module

Field wiring power is provided externally, therefore, Series C protection is not required.

5.8.2 IOTA board and connections - Digital Input High Voltage module

Series C Digital Input High Voltage 9 inch, non-redundant IOTA is displayed.

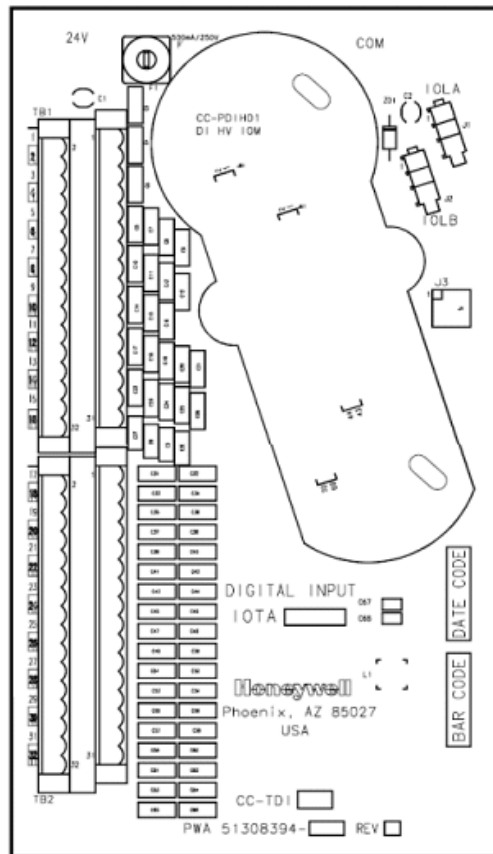

Figure 36: Series C Digital Input High Voltage 9 inch, non-redundant IOTA

Series C Digital Input High Voltage 12 inch, redundant IOTA is displayed.

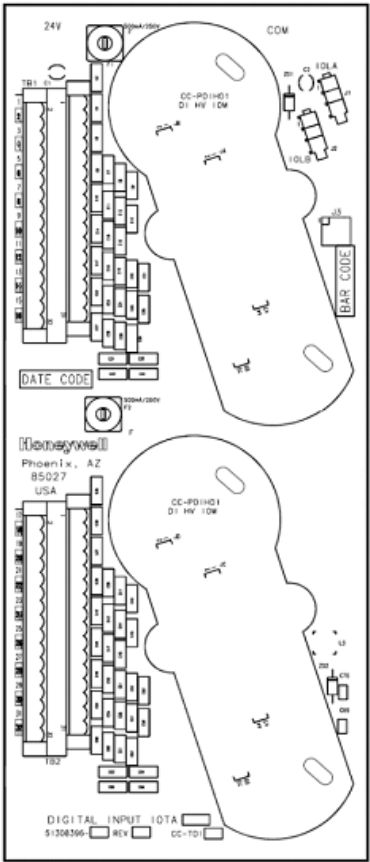

Figure 37: Series C Digital Input High Voltage 12 inch, redundant IOTA

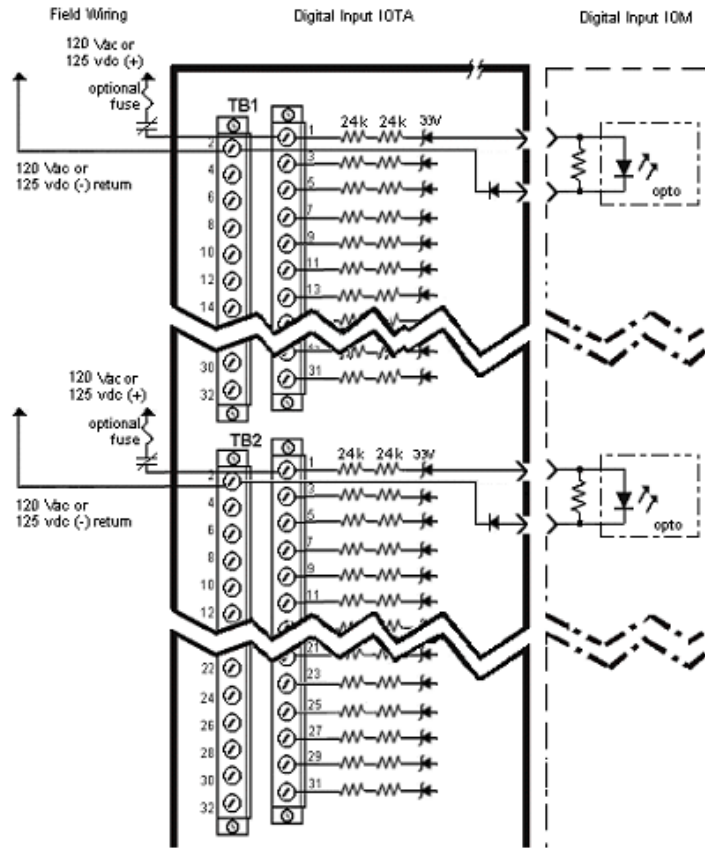

Figure 38: Series C Digital Input High Voltage 120 Vac and field wiring connections

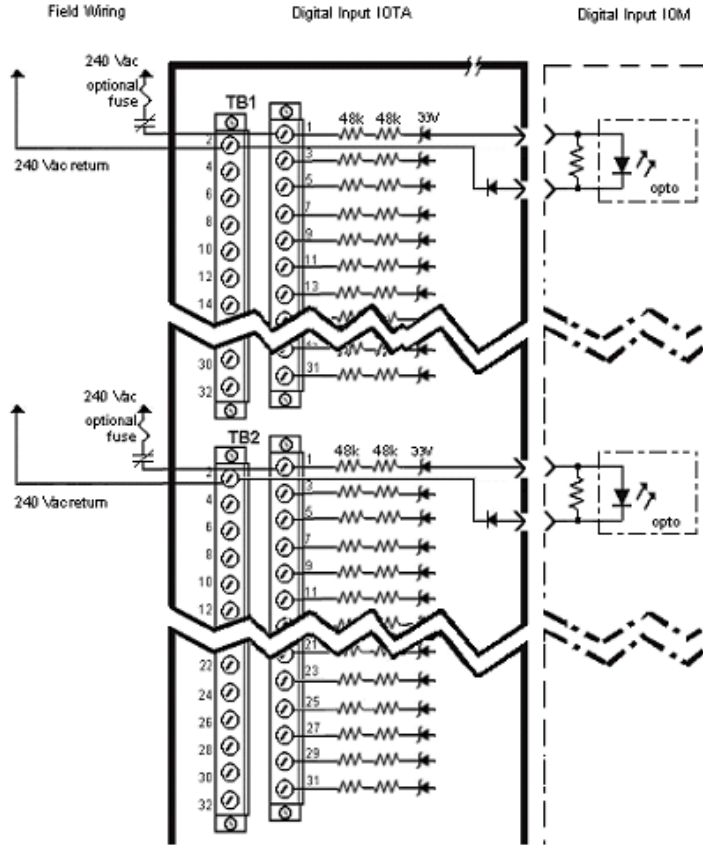

Figure 39: Series C Digital Input High Voltage 240 Vac and field wiring connections

To properly wire your module to the Series C Digital Input High Voltage IOTA board with terminal blocks 1 (TB1) and 2 (TB2) use the following table.

Table 41: DI HV 12 inch, redundant - terminal block 1

Terminal block 1		
Channel	Return screw	Power screw
Channel 1	2	1
Channel 2	4	3
Channel 3	6	5
Channel 4	8	7
Channel 5	10	9
Channel 6	12	11
Channel 7	14	13
Channel 8	16	15
Channel 9	18	17
Channel 10	20	19
Channel 11	22	21
Channel 12	24	23
Channel 13	26	25

Terminal block 1		
Channel	Return screw	Power screw
Channel 14	28	27
Channel 15	30	29
Channel 16	32	31

Table 42: DI HV 12 inch, redundant - terminal block 2

Terminal block 2		
Channel	Return screw	Power screw
Channel 17	2	1
Channel 18	4	3
Channel 19	6	5
Channel 20	8	7
Channel 21	10	9
Channel 22	12	11
Channel 23	14	13
Channel 24	16	15
Channel 25	18	17
Channel 26	20	19
Channel 27	22	21
Channel 28	24	23
Channel 29	26	25
Channel 30	28	27
Channel 31	30	29
Channel 32	32	31

5.9 Digital Input High Voltage PROX IOTA Model Cx-TDI151

The Series C Digital Input High Voltage PROX IOTA board is represented by the following information and graphics.

To access the parts information for the:

- module
- IOTA
- terminal plug-in assembly, and
- fuses

associated with this board and module, see the “Recommended Spare Parts” table in the “IOM removal and installation under power” on page 542 section.

5.9.1 Difference between CC-TDI151 and CC-TDI110/CC-TDI120 IOTAs

The following table lists the differences between CC-TDI151 and CC-TDI110/CC-TDI120 IOTAs.

Table 43: Difference between CC-TDI151 and CC-TDI110/CC-TDI120 IOTAs

CC-TDI151	CC-TDI110/CC-TDI120
Size of non-redundant IOTA is 12 inch.	Size of non-redundant IOTA is 9 inch.
Sensor current for ON condition is 7.5 mA at 90 voltage and 10 mA at 132 voltage.	Sensor current for ON condition is 1 mA at both 90 and 120 voltages.
Sensor current for OFF condition is 2 mA.	Sensor current for OFF condition is 0.32 mA.

5.9.2 Field wiring and module protection - Digital Input High Voltage PROX IOTA (Cx - TDI151)

Field wiring power is provided externally, therefore, Series C protection is not required.

5.9.3 IOTA board and connections - Digital Input High Voltage module

Series C Digital Input High Voltage 12 inch, non-redundant PROX IOTA is displayed.

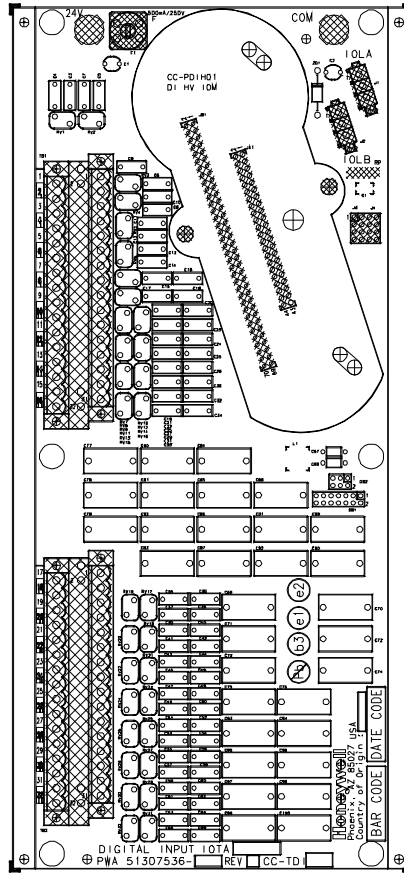

Figure 40: Series C Digital Input High Voltage 12 inch, non-redundant PROX IOTA

To properly wire your module to the Series C Digital Input High Voltage PROX IOTA board with terminal blocks 1 (TB1) and 2 (TB2) use the following table.

Table 44: DI HV 12 inch, non-redundant - terminal block 1

Terminal block 1		
Channel	Return screw	Power screw
Channel 1	2	1
Channel 2	4	3
Channel 3	6	5
Channel 4	8	7
Channel 5	10	9
Channel 6	12	11
Channel 7	14	13
Channel 8	16	15
Channel 9	18	17
Channel 10	20	19
Channel 11	22	21
Channel 12	24	23
Channel 13	26	25

Terminal block 1		
Channel	Return screw	Power screw
Channel 14	28	27
Channel 15	30	29
Channel 16	32	31

Table 45: DI HV 12 inch, non-redundant - terminal block 1

Terminal block 2		
Channel	Return screw	Power screw
Channel 17	2	1
Channel 18	4	3
Channel 19	6	5
Channel 20	8	7
Channel 21	10	9
Channel 22	12	11
Channel 23	14	13
Channel 24	16	15
Channel 25	18	17
Channel 26	20	19
Channel 27	22	21
Channel 28	24	23
Channel 29	26	25
Channel 30	28	27
Channel 31	30	29
Channel 32	32	31

The field wiring connection of the Series C Digital Input High Voltage PROX IOTA is displayed in the following figure.

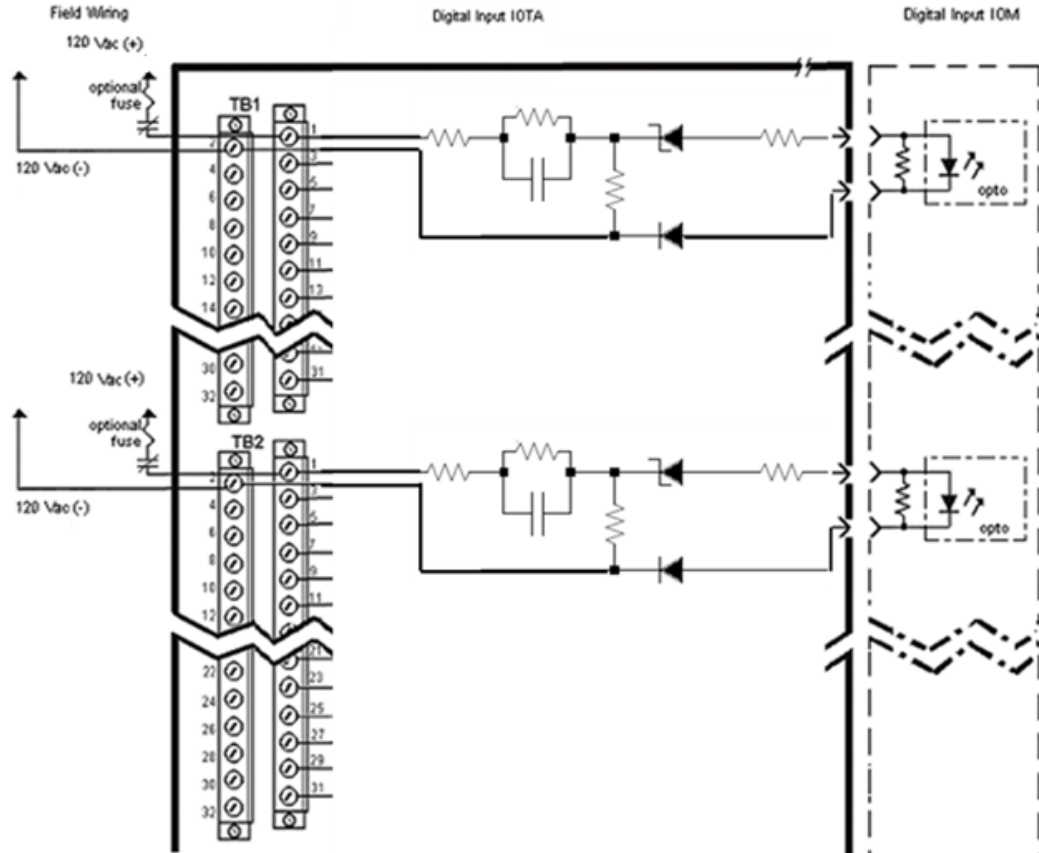

Figure 41: Field wiring connection of Series C Digital Input High Voltage PROX IOTA

5.10 Digital Input 24V IOTA Models CC-TDIL01, CC-TDIL11

The Series C Digital Input 24V IOTA board is represented by the following information and graphics.

To access the parts information for the:

- module
- IOTA
- terminal plug-in assembly, and
- fuses

associated with this board and module, refer to Digital Input 24V in the Recommended Spare Parts section.

5.10.1 Field wiring and module protection - Digital Input 24V module (CC-TDIL01, CC-TDIL11)

Field wiring is protected by an internal protection circuit which:

- Allows for internal or external DI sense power (field selectable using jumper block TB3)
- Permits short circuit protection of input for field short circuits. Protection suitable for Division 2 non-incendive / Zone 2 non-arcing.
- Allows each signal to be shorted in the field with no damage to module or board. Other channels on the same IOM are not affected.
- Field drive current is limited. Short circuit of input allowed.

Series C 24V Digital Input 9 inch, non-redundant IOTA is displayed.

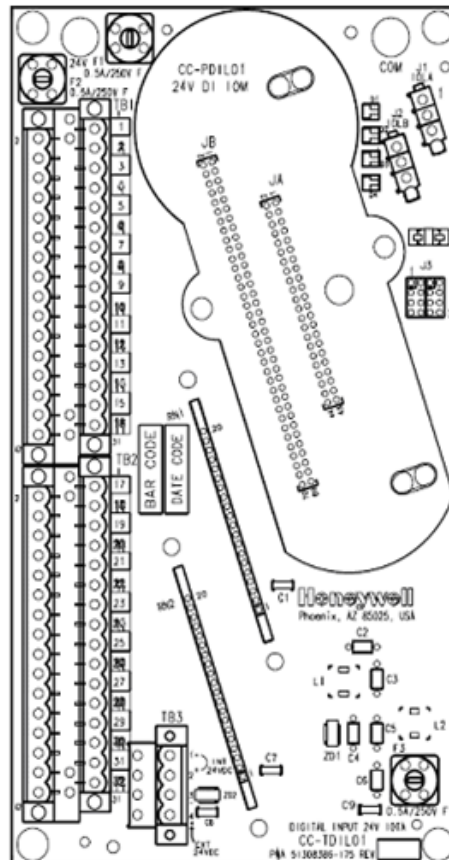

Figure 42: Series C 24V Digital Input 9 inch, non-redundant IOTA

To properly wire your module to the Series C Digital Input IOTA board with terminal blocks 1 (TB1), 2 (TB2), and 3 (TB3), use the following table.

Table 46: DI 9 inch, non-redundant - terminal block 1

Terminal block 1		
Channel	Return screw	Power screw
Channel 1	2	1
Channel 2	4	3
Channel 3	6	5
Channel 4	8	7
Channel 5	10	9
Channel 6	12	11
Channel 7	14	13
Channel 8	16	15
Channel 9	18	17
Channel 10	20	19
Channel 11	22	21
Channel 12	24	23
Channel 13	26	25
Channel 14	28	27
Channel 15	30	29
Channel 16	32	31

Table 47: DI 9 inch, non-redundant - terminal block 2

Terminal block 2		
Channel	Return screw	Power screw
Channel 17	2	1
Channel 18	4	3
Channel 19	6	5
Channel 20	8	7
Channel 21	10	9
Channel 22	12	11
Channel 23	14	13
Channel 24	16	15
Channel 25	18	17
Channel 26	20	19
Channel 27	22	21
Channel 28	24	23
Channel 29	26	25
Channel 30	28	27
Channel 31	30	29
Channel 32	32	31

Table 48: DI 9 inch, non-redundant - terminal block 3

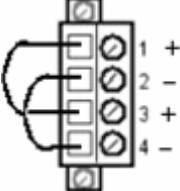
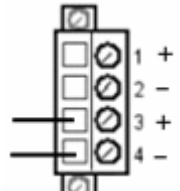
Terminal block 3	
Internal	Used with Honeywell's 24v power supply
Screw 1 - internal 24V	
Screw 2 - internal return	
Screw 3 - external 24V	
Screw 4 - external return	
External	Used with customer's 24v power supply
Screw 1 - internal 24V	
Screw 2 - internal return	
Screw 3 - external 24V	
Screw 4 - external return	

Series C 24V Digital Input 9 inch, non-redundant IOTA and field wiring connection is displayed.

**Tip**

Optional open-wire detection can be instituted by attaching a 22k ohm resistor in the field wiring.

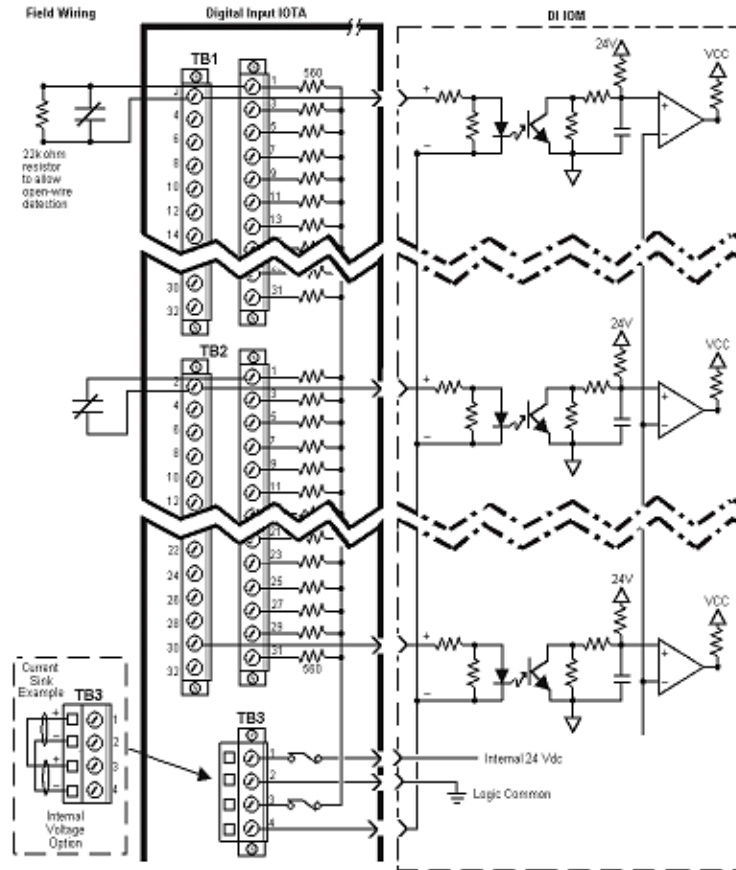

Figure 43: Series C 24V Digital Input 9 inch, non-redundant IOTA and field wiring connection

Series C 24V Digital Input 12 inch, redundant IOTA is displayed.

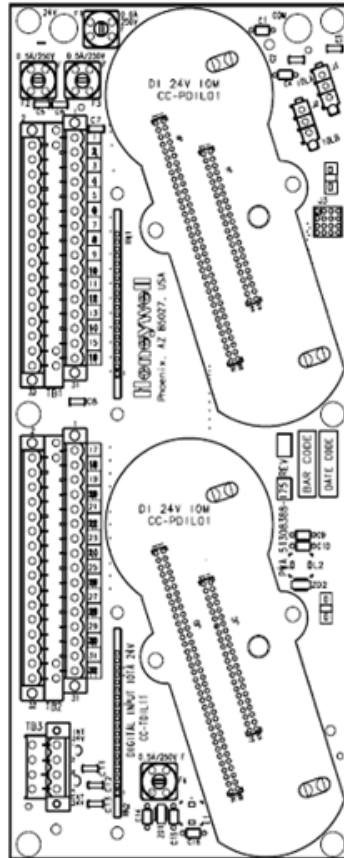

Figure 44: Series C 24V Digital Input 12 inch, redundant IOTA

5.10.2 Using DI 24V module (CC-TDIL01, CC-TDIL11) channels to report system alarms

You must include digital input channels in the control strategy to generate and report alarms based on their PVs. A typical strategy consists of a Control Module that contains the DI channel blocks where each PV (output) is connected to a PVFL input of a FLAGARRAY block configured for alarming.

The normal condition of the alarm input is ON.

Refer to the Control Building Guide for the following topics

- Creating and saving a control module
- Creating an instance of a basic function block
- Configuring alarms

Prerequisites

- You have installed and configured Series C 24V digital input I/O modules and associated IOTAs.
- You have alarm cables 51202343-001 (12-foot long) to connect power supply alarm contacts to 24V dc digital inputs on the IOM.

To connect the Power System alarm cable for RAM Charger Assembly 5119932-100

- 1 Plug the connection end of the alarm cable into the alarm connection on top of the power supply.
- 2 Connect the twisted pair wires to the terminal block 1 on the DI 24V IOTA in the following configuration. The associated alarm pins are also displayed.

TERMINAL BLOCK 1			PWR SUPPLY ALARM CONNECTOR	
Wire color	Channel	Screw	Description	
White	1	1	Power supply 1 alarm +	(pin 8)
Black	1	2	Power supply 1 alarm -	(pin 3)
Blue	2	3	Power supply 2 alarm +	(pin 7)
Black	2	4	Power supply 2 alarm -	(pin 4)
Red	3	5	Battery alarm +	(pin 2)
Black	3	6	Battery alarm -	(pin 1)
Green	4	7	RAM charger cable alarm +	(pin 6)
Black	4	8	RAM charger cable alarm -	(pin 5)

- Ensure terminal block 3 connections are made in the following configuration
 Screw 1 + (internal 24V) to Screw 3 + (external 24V)
 Screw 2 - (internal return) to Screw 4 - (external return)

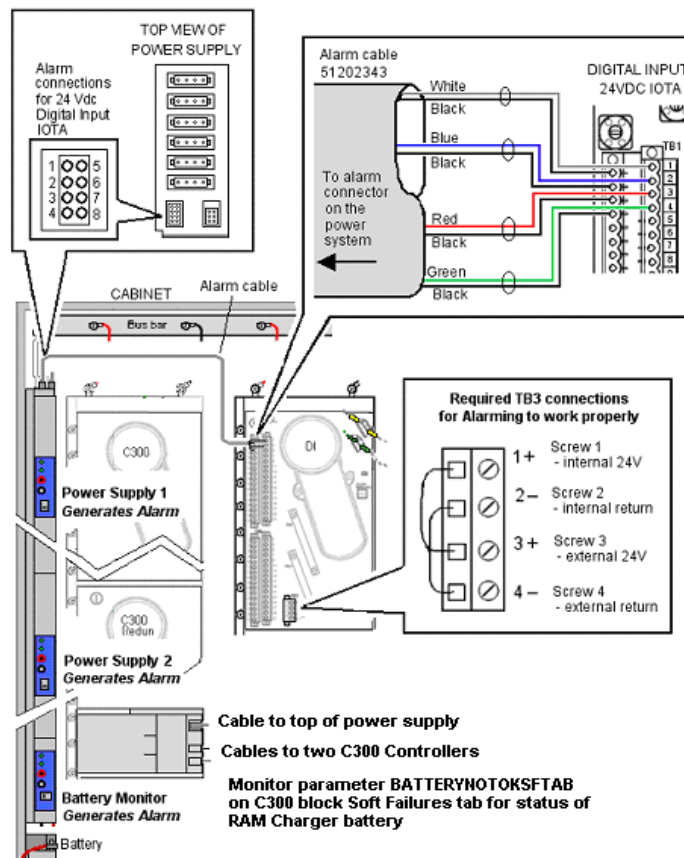

Figure 45: Alarm cable connection to the power supply and 24V DI IOTA for RAM Charger Assembly 51199932-100

5.10.3 Connecting the Power System alarm cable for RAM Charger Assembly 51199932-200

- Plug the connection end of the alarm cable into the alarm connection on top of the power supply.
- Connect the twisted pair wires to the terminal block 1 on the DI 24V IOTA in the following configuration. The associated alarm pins are also displayed.

TERMINAL BLOCK 1			PWR SUPPLY ALARM CONNECTOR (20A power system)	
Wire color	Channel	Screw	Description	
White	1	1	Power supply 1 alarm +	(pin 8)
Black	1	2	Power supply 1 alarm -	(pin 3)
Blue	2	3	Power supply 2 alarm +	(pin 7)
Black	2	4	Power supply 2 alarm -	(pin 4)
Red	3	5	Battery alarm +	(pin 2)
Black	3	6	Battery alarm -	(pin 1)
Green	4	7	Not Used (No Cable)	
Black	4	8	Not Used (No Cable)	

- 3 Ensure terminal block 3 connections are made in the following configuration
 Screw 1 + (internal 24V) to Screw 3 + (external 24V)
 Screw 2 - (internal return) to Screw 4 - (external return)

TERMINAL BLOCK 1			PWR SUPPLY ALARM CONNECTOR (40A power system)	
Wire color	Channel	Screw	Description	
White	1	1	Power supply 1 alarm +	(pin 8)
Black	1	2	Power supply 1 alarm -	(pin 3)
Blue	2	3	Power supply 2 alarm +	(pin 7)
Black	2	4	Power supply 2 alarm -	(pin 4)
Red	3	5	Power supply 3 alarm +	(pin 1)
TERMINAL BLOCK 1			PWR SUPPLY ALARM CONNECTOR (40A power system)	
Wire color	Channel	Screw	Description	
Black	3	6	Power supply 3 alarm -	(pin 2)
Green	4	7	Not Used (No Cable)	
Black	4	8	Not Used (No Cable)	

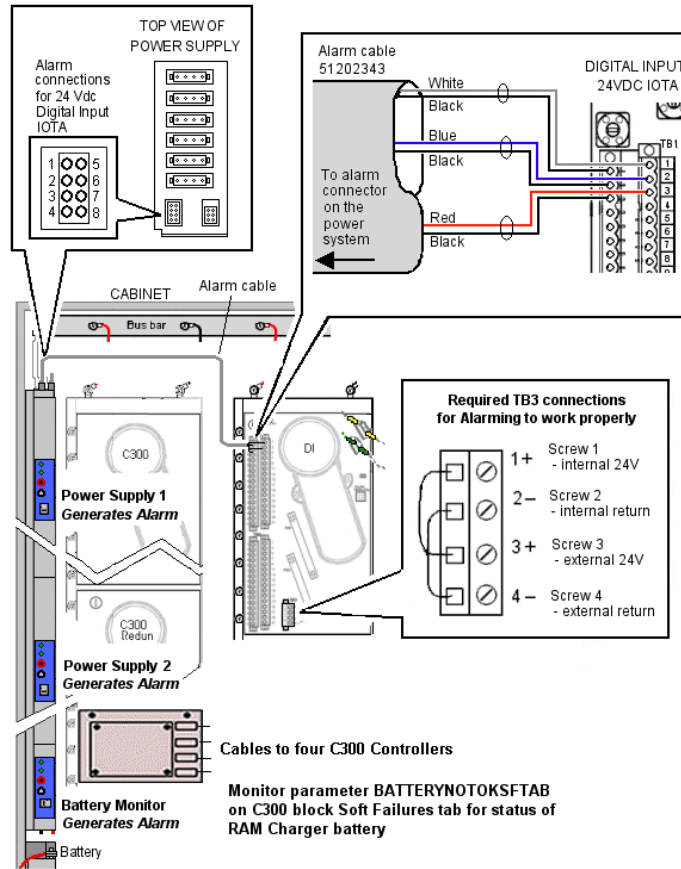

Figure 46: Alarm cable connection to the power supply and 24V DI IOTA for RAM Charger Assembly 51199932-200

5.11 Digital Input 24V IOTA Models Cx - TDIL51, Cx - TDIL61

The Series C Digital Input 24V IOTA board is represented by the following information and graphics.

To access the parts information for the:

- module
- IOTA
- terminal plug-in assembly, and
- fuses

associated with this board and module, refer to Digital Input 24V in the Recommended Spare Parts section.

5.11.1 Field wiring and module protection - Digital Input 24V module (Cx - TDIL51, Cx - TDIL61)

Field wiring is protected by an internal protection circuit, which:

- Allows for internal or external DI sense power (field selectable using jumper block TB3)
- Permits short circuit protection of input for field short circuits. Protection suitable for Division 2 non-incident / Zone 2 non-arcing.
- Allows each signal to be shorted in the field with no damage to module or board. Other channels on the same IOM are not affected.
- Field drive current is limited. Short circuit of input allowed.

Series C 24V Digital Input 9 inch, non-redundant IOTA is displayed.

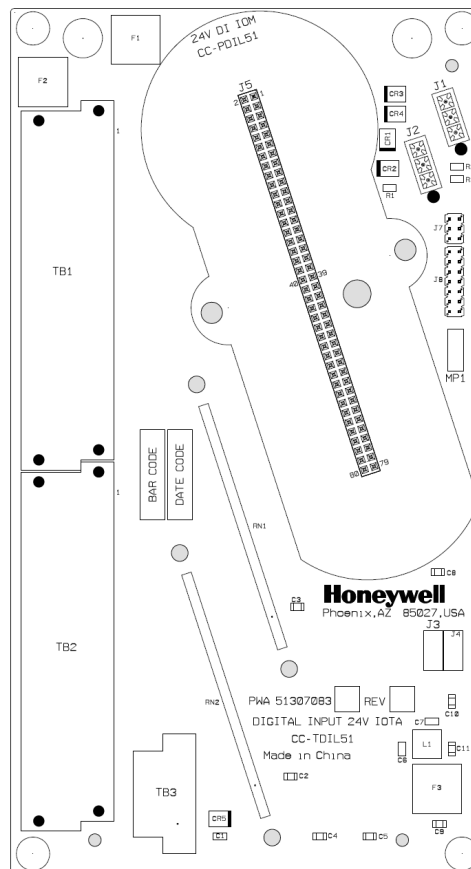

Figure 47: Series C 24V Digital Input 9 inch, non-redundant IOTA

To wire your module to the Series C Digital Input IOTA board with terminal blocks 1 (TB1), 2 (TB2), and 3 (TB3), use the following table.

Table 49: DI 9 inch, non-redundant - terminal block 1

Terminal block 1		
Channel	Return screw	Power screw
Channel 1	2	1
Channel 2	4	3
Channel 3	6	5
Channel 4	8	7
Channel 5	10	9
Channel 6	12	11
Channel 7	14	13
Channel 8	16	15
Channel 9	18	17
Channel 10	20	19
Channel 11	22	21
Channel 12	24	23
Channel 13	26	25
Channel 14	28	27
Channel 15	30	29
Channel 16	32	31

Table 50: DI 9 inch, non-redundant - terminal block 2

Terminal block 2		
Channel	Return screw	Power screw
Channel 17	2	1
Channel 18	4	3
Channel 19	6	5
Channel 20	8	7
Channel 21	10	9
Channel 22	12	11
Channel 23	14	13
Channel 24	16	15
Channel 25	18	17
Channel 26	20	19
Channel 27	22	21
Channel 28	24	23
Channel 29	26	25
Channel 30	28	27
Channel 31	30	29
Channel 32	32	31

Table 51: DI 9 inch, non-redundant - terminal block 3

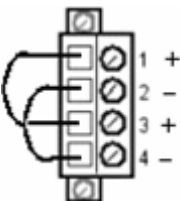
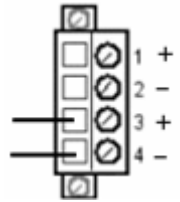
Terminal block 3	
Internal	Used with Honeywell's 24v power supply
Screw 1 - internal 24V	
Screw 2 - internal return	
Screw 3 - external 24V	
Screw 4 - external return	
External	Used with customer's 24v power supply
Screw 1 - internal 24V	
Screw 2 - internal return	
Screw 3 - external 24V	
Screw 4 - external return	

Series C 24V Digital Input 9 inch, non-redundant IOTA and field wiring connection is displayed.

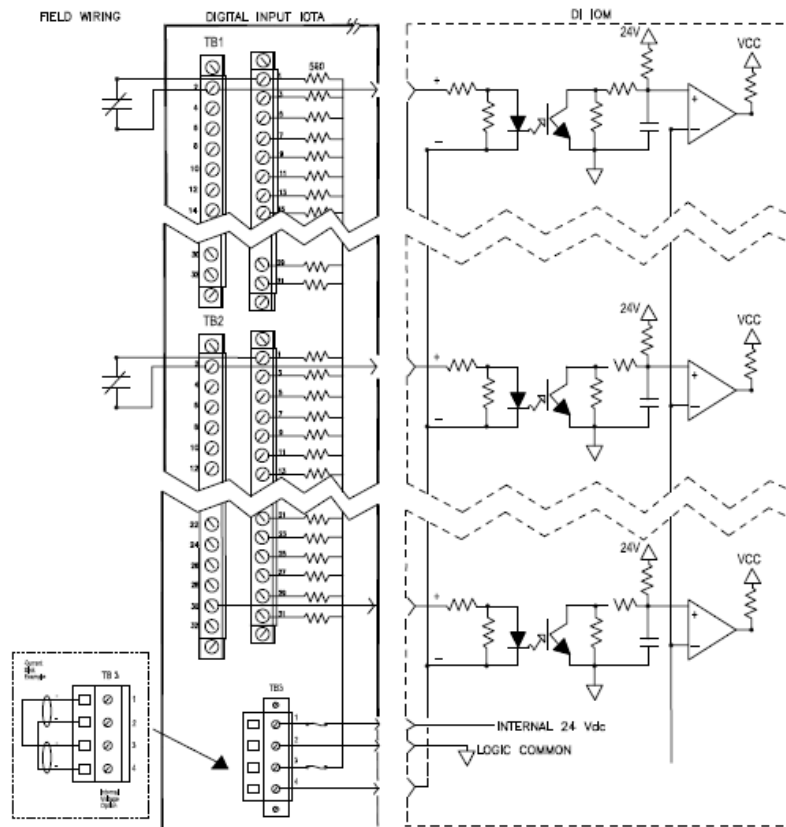

Figure 48: Series C 24V Digital Input 9 inch, non-redundant IOTA and field wiring connection

Series C 24V Digital Input 9 inch, redundant IOTA is displayed.

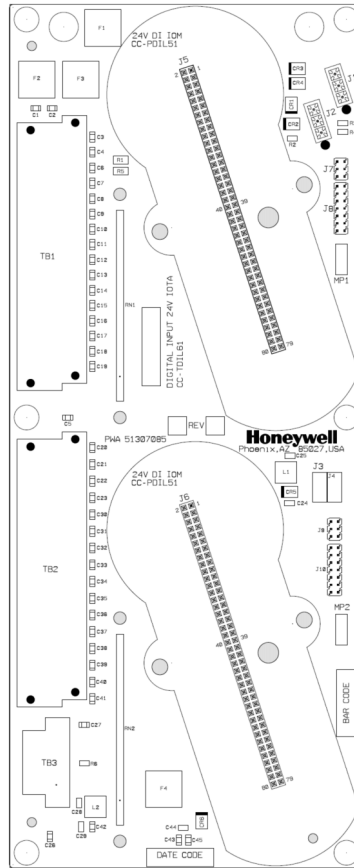

Figure 49: Series C 24V Digital Input 9 inch, redundant IOTA

5.11.2 Using DI 24V module (Cx - TDIL51, Cx - TDIL61) channels to report system alarms

You must include digital input channels in the control strategy to generate and report alarms based on their PVs. A typical strategy consists of a Control Module that contains the DI channel blocks where each PV (output) is connected to a PVFL input of a FLAGARRAY block configured for alarming.

The normal condition of the alarm input is ON.

Refer to the Control Building Guide for the following topics

- Creating and saving a control module
- Creating an instance of a basic function block
- Configuring alarms

Prerequisites

- You have installed and configured Series C 24V digital input I/O modules and associated IOTAs.
- You have alarm cables 51202343-001 (12-foot long) to connect power supply alarm contacts to 24V dc digital inputs on the IOM.

To connect the Power System alarm cable for RAM Charger Assembly 5119932-200

- 1 Plug the connection end of the alarm cable into the alarm connection on top of the power supply.
- 2 Connect the twisted pair wires to the terminal block 1 on the DI 24V IOTA in the following configuration. The associated alarm pins are also displayed.