

**8-Node  
Enhanced Micro TDC 3000  
User's Manual**

MT11-520

---



**Implementation  
8-Node Micro TDC 3000**

***8-Node  
Enhanced Micro TDC 3000  
User's Manual***

**MT11-520  
Release 500  
CE Compliant  
9/95**

---

# Copyright, Trademarks, and Notices

**Printed in U.S.A. – © Copyright 1995 by Honeywell Inc.**

**Revision 01 – September 15, 1995**

While this information is presented in good faith and believed to be accurate, Honeywell disclaims the implied warranties of merchantability and fitness for a particular purpose and makes no express warranties except as may be stated in its written agreement with and for its customer.

In no event is Honeywell liable to anyone for any indirect, special or consequential damages. The information and specifications in this document are subject to change without notice.

## About This Publication

This publication is provided for users of the Enhanced Micro TDC 3000 Control System. Basic information relating to installation, checkout, implementation, and operation are covered.

This publication is to be used in conjunction with the remainder of the TDC 3000<sup>X</sup> bookset.

This publication supports MicroTDC 3000 system software release 500. It also contains hardware information about the ElectroMagnetic Compatibility Directive for European standards.

Any equipment designated as “CE Compliant” complies with the European Union EMC and Health and Safety Directives. All equipment shipping into European Union countries after January 1, 1996 require this type of compliance—denoted by the “CE Mark.”

# Standard Symbols

## Scope

The following defines standard symbols used in this publication

### ATTENTION

Notes inform the reader about information that is required, but not immediately evident

### CAUTION

Cautions tell the user that damage may occur to equipment if proper care is not exercised

### WARNING

Warnings tell the reader that potential personal harm or serious economic loss may happen if instructions are not followed

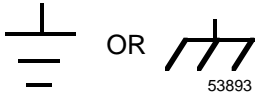

Ground connection to building safety ground

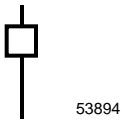

Ground stake for building safety ground



Electrical Shock Hazard—can be lethal

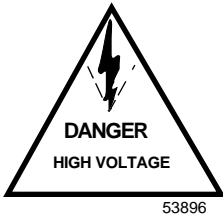

Electrical Shock Hazard—can be lethal

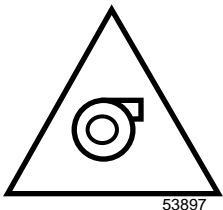

Rotating Fan—can cause personal injury

---

# Table of Contents

---

## 1 INTRODUCTION AND OVERVIEW

- 1.1 General Description
  - 1.1.1 Basic Enhanced Micro TDC 3000 Systems
  - 1.1.2 Options to the System
  - 1.1.3 The Operator's Keyboard
  - 1.1.4 The Engineer's Keyboard
  - 1.1.5 The Local Control Network
- 1.2 Operating Practices and Housekeeping
  - 1.2.1 Before Startup
  - 1.2.2 After Startup
- 1.3 Circuit Card Handling
- 1.4 Cartridge Disk Handling and Storage
  - 1.4.1 Cartridge Loading and Removal
  - 1.4.2 Cartridge Media Protection
- 1.5 EMC Directive
- 1.6 Related Publications

## 2 SITE PREPARATION AND INSTALLATION

- 2.1 Storage Conditions
- 2.2 Site Requirements
  - 2.2.1 Dimensions and Weight
- 2.3 Electrical Requirements
  - 2.3.1 AC Voltage Options
  - 2.3.2 Frequency
  - 2.3.3 Current in Amperes at 120 Vac
- 2.4 Unpacking
- 2.5 Site Layout
- 2.6 Installation
- 2.7 Tower #1 Equipment Cabling
  - 2.7.1 Cabling - Standard
  - 2.7.2 Cabling - EMC Directive
  - 2.7.3 Cabling EPDG I/O Board - Standard
  - 2.7.4 Cabling EPDGC I/O Board
  - 2.7.5 Operator Keyboard Cabling
  - 2.7.6 Printer Cabling
  - 2.7.7 Color Monitor Cabling
  - 2.7.8 Engineer's Keyboard Cabling
  - 2.7.9 TPLCN Cabling
  - 2.7.10 Touchscreen Cabling
  - 2.7.11 Trackball Cabling
  - 2.7.12 Process Cabling
  - 2.7.13 Cabling Diagram and Parts List–Track Ball
  - 2.7.14 Cabling Diagram and Parts List–Touch

---

# Table of Contents

---

2.8	Tower #2 Equipment Cabling
2.8.1	Optional Universal Station Upgrade
2.8.2	Optional Redundant Network Interface Module
2.8.3	Optional Computer Gateway CLI I/O
2.8.4	Optional Computer Gateway CLI/A I/O
2.8.5	Optional PLC Gateway
2.9	Optional LCN Upgrade
2.10	Installation Wrap-Up
<b>3</b>	<b>CHECKOUT</b>
3.1	Power-On Tests
3.1.1	Tower #1 Electronics Checks
3.1.2	Tower #2 Electronics Checks
3.1.3	Color Monitor Check
3.1.4	Printer Checks
3.1.5	Cartridge Drive Checks
3.2	System Checkout Wrap-Up
<b>4</b>	<b>IMPLEMENTATION</b>
4.1	Implementation Overview
4.1.1	Database Configuration
4.1.2	The Implementation Process
4.2	System Startup
4.2.1	Local Control Network Configuration
4.2.2	Prebuilt Network Configuration Data
4.3	Load Gateways and Modules
4.3.1	Loading the AM
4.3.2	Loading the NIM
4.4	Load the Process Manager
4.4.1	Standard Double-Sided Nonredundant PM Cabinet
4.4.2	Expanded Standard PM Cabinet
4.4.3	UCN/PM Box Point Configuration Data
4.5	Loading the PLCG or CG
4.6	Data Point Building



---

# Table of Contents

---

4.7	Custom Functions
4.7.1	Build Pictures
4.7.2	Build Free Format Logs
4.7.3	Configure Buttons
4.7.4	Prepare User-Written Programs
4.8	Area Database Configuration
4.8.1	Install the Area Database
4.8.2	Area Database Prebuilt Configuration Data
4.9	Configuration Completion
<b>5</b>	<b>OPERATIONAL GUIDELINES</b>
5.1	The Engineering and Operator Personalities
5.1.1	How to Load and Change US Personalities
5.2	Loading the Modules and Gateways
5.2.1	Loading the Application Module
5.2.2	Loading Network Interface Module and UCN Devices
5.2.3	Loading the History Module
5.3	System Operation
5.3.1	Calling Up Operating Displays
5.3.2	The Area Database
5.3.3	Keyswitch Access Levels
5.4	Monitor Operation
5.4.1	IDEK Model MF-5221
5.4.2	IDEK Model MF-8221
5.4.3	HITACHI Model HM-4821-D
<b>6</b>	<b>SERVICE</b>
6.1	Overview
6.2	Field Adjustments
6.2.1	LCN Node Addressing (Pinning)
6.2.2	UCN Node Addressing (Pinning)
6.2.3	21-Inch Monitor Adjustments
6.3	Cleaning
6.3.1	Air Filter Removal and Cleaning
6.4	Troubleshooting
6.5	Spare Parts
6.6	Hardware Verification Test System (HVTS) Overview
<b>A</b>	<b>APPENDIX A PREBUILT POINTS</b>
<b>B</b>	<b>APPENDIX B BUTTON CONFIGURATION</b>
	<b>INDEX</b>



## INTRODUCTION AND OVERVIEW

### Section 1

The Enhanced Micro TDC 3000 Control System is an extremely compact, yet fully functional control system in the Honeywell TDC 3000<sup>X</sup> family. Figure 1-1 is an illustration of the basic Enhanced Micro TDC 3000 Control System. This control system communicates to the process via the Honeywell Universal Control Network (UCN). The process can be monitored and controlled by Program Manager or Advanced Process Manager.

This manual describes the Enhanced Micro TDC 3000 system. The system comes in two models. The model numbers are:

Model Number	Hardware Components
MX-DTAB01	K2LCN, 1 US, w/APM, 4MW AM, 875 MB HM.
MX-DTAC01	K2LCN, 1 US, w/APM, 8MW AM, 875 MB HM.

The Enhanced Micro TDC 3000 models have the following characteristics and features:

- Only “version A” models (with 1 US node) are offered as the base system. The old “version B” models (with 2 US nodes) are no longer offered as a base system (the old “version B” models are equivalent to a “version A” model, plus an optional US node).
- All nodes are equipped with K2LCN processors.
- The base models will include an Advanced Process Manager (APM) as standard equipment.
- The minimum AM processor memory is 4 MW (the base system models are offered with AM nodes in two memory sizes — either 4 MW or 8 MW).
- The US included with the base system has 6 MW processor memory and supports ‘*Universal*’ personality.
- The US node in the base system is equipped with dual 150 MB Bernoulli cartridge ‘multi-drives’. The new ‘multi-drives’ are compatible with 35 MB
- The HM included in the base system has a 875 MB hard drive and 3 MW processor memory.
- The NIM included in the base system has 3 MW processor memory.
- The US monitor and printer are not included with the “R500-Ready” Enhanced Micro TDC 3000 models. These two peripherals have their own model numbers and must be ordered separately. The operator’s keyboard, however, is included with the base system model.
- The Enhanced Micro TDC 3000 models will not support U<sup>X</sup>S or A<sup>X</sup>M. There are currently no plans to provide U<sup>X</sup>S or A<sup>X</sup>M options with the system.

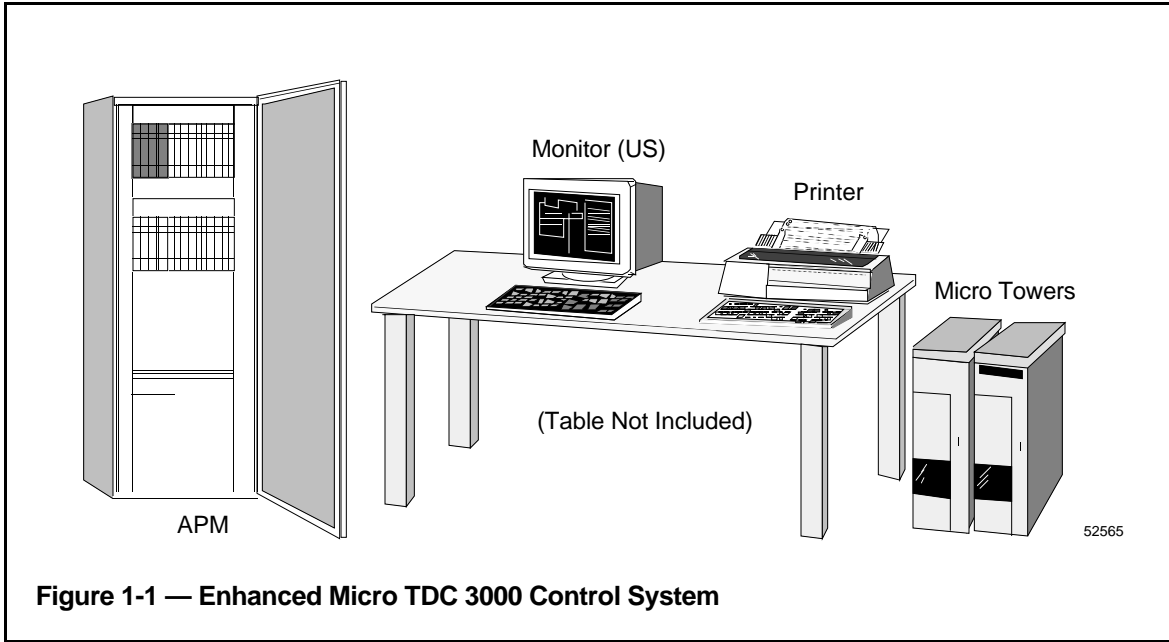

**Figure 1-1 — Enhanced Micro TDC 3000 Control System**

## 1.1 GENERAL DESCRIPTION

The Enhanced Micro TDC 3000 Control System consists of two cabinets (also called "towers") which together contain the electronics, two cartridge disk drives, and a history module. The cabinet electronics support up to four color monitors, four keyboards, and optional touchscreens or trackballs. A printer is also connected to the system.

Two electronics modules, one housed in each tower, provide all of the electronics for the Enhanced Micro TDC 3000 Control System (excluding peripherals). These modules, called Multinode Modules, are each capable of holding four TDC 3000 Nodes.

Although the Advanced Process Manager (APM) is part of the Enhanced Micro TDC 3000 Control System, it is not described in this manual. See subsection 1.5 for a list of publications that discuss the Advanced Process Manager and the Universal Control Network (UCN).

Figure 1-2 is a representation of some of the nodes used to construct a sample Enhanced Micro TDC 3000 Control System.

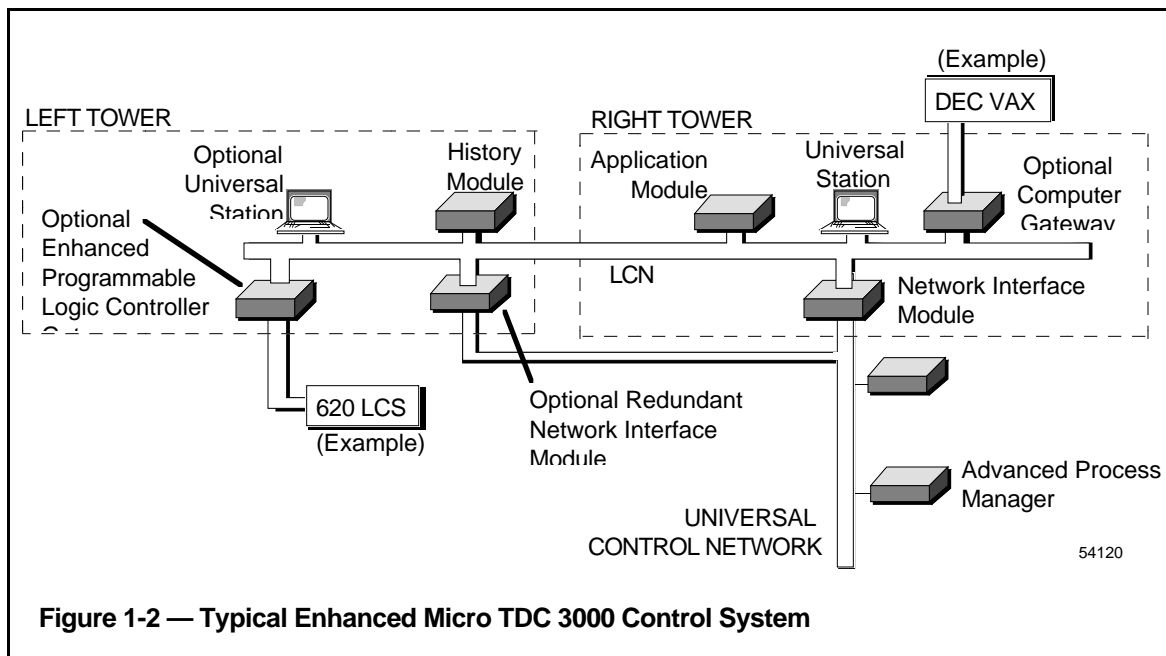

Figure 1-2 — Typical Enhanced Micro TDC 3000 Control System

### 1.1.1 Basic Enhanced Micro TDC 3000 Systems

The Enhanced Micro TDC 3000 Control System is furnished with one basic version. This is the single US Micro TDC 3000.

The base version consists of two 4-node towers, an operator's keyboard, an engineer's keyboard, a color monitor and printer (ordered separately), and the Advanced Process Manager. Four nodes are contained within the two towers:

1. **US—UNIVERSAL STATION** A window to the process—allows all information supplied from process-connected devices, instrumentation subsystems, and computers to be seen and used. The color monitor, two keyboards, an optional touchscreen or trackball, two cartridge disk drives, and the ASPI-41 printer are integral parts of the Universal Station.
2. **AM—APPLICATION MODULE** Performs calculations and control strategies that are not possible or practical using only process-connected devices. The Application Module has 4 or 8 megawords of memory.
3. **NIM—NETWORK INTERFACE MODULE** Connects the Enhanced Micro TDC 3000 Control System to a process controller, generally to a Advanced Process Manager.
4. **HM—HISTORY MODULE** Provides mass storage of software, system data, and customer/user data.

### 1.1.2 Options to the System

Monitors, touchscreens or trackballs, and printers are options to all the Universal Stations in all versions of systems. A touchscreen or trackball allows you to "point" to areas on the graphic display and select operations to be performed. Without either of these options, you must use directional keys (arrows) on the keyboards to navigate across the screen.

Up to four additional nodes, making a total of eight nodes, may be added to basic Enhanced Micro TDC 3000 Control System. Choose from the following:

1. **NIM—REDUNDANT NETWORK INTERFACE MODULE** Provides a second path to the process controller in the event of an electrical failure.
2. **US—UNIVERSAL STATION** (4Mw and 6Mw) Provides a window to the process.
3. **EPLCG—ENHANCED PROGRAMMABLE LOGIC CONTROLLER GATEWAY** Provides a path to one or more Programmable Logic Controllers.
4. **PLNM—PLANT NETWORK MODULE** Provides the hardware and software to link the LCN to the VAX interfaces.
5. **CG—COMPUTER GATEWAY** Provides a path to a host computer.
6. **NG—NETWORK GATEWAY** Provides a path to an alternate network for an integrated plant solution (single and dual cable).

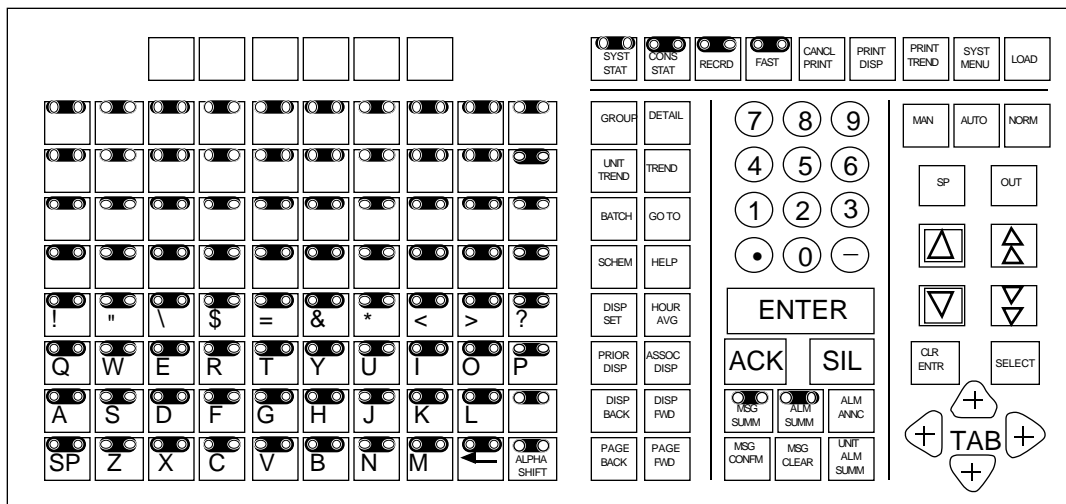

Qwerty Operator's Keyboard

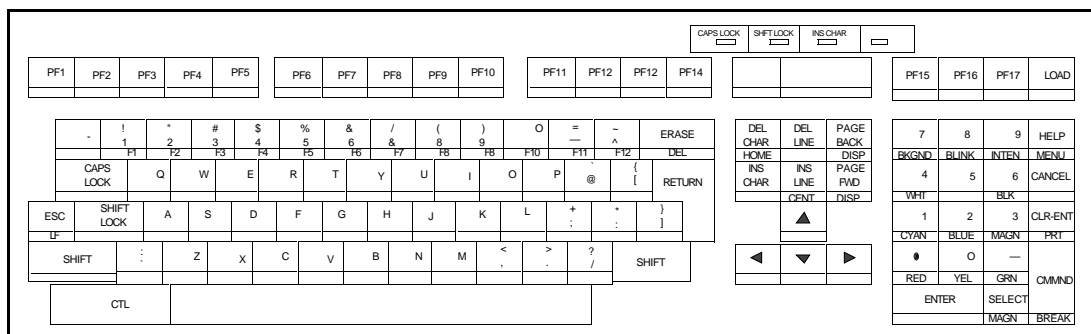

Engineer's Keyboard

Figure 1-3 — Enhanced Micro TDC 3000 Keyboards

5891

### 1.1.3 The Operator's Keyboard

The Operator's Keyboard (Figure 1-3) is a flat, chemically resistant, membrane keyboard installed in a metal frame, placeable by the operator, and connected to the keyboard connector on the transition panel. A three-function annunciator horn is built into these keyboards.

Unmarked keys on the left side of the operator's keyboard may be configured by the user (or, perhaps, be preconfigured at the factory). An insert sheet is available that is placed between the outside protective membrane and the keyboard electronics. To replace or install a new insert, remove the two corner screws beneath the metal frame. Lift the frame from the keyboard assembly, grasp the plastic insert using the thumb-slot at the top of the keyboard and remove it. Replace it with the new insert. Reassemble the keyboard and frame, then install and tighten the two corner screws.

Additional operator's keyboards are supplied with optional Universal Stations.

### 1.1.4 The Engineer's Keyboard

At least one engineer's keyboard (Figure 1-3), similar in design to a personal computer keyboard, will be connected to the system. The engineer's keyboard is especially designed so that it may be disconnected and/or reconnected while the system is in operation. This way, the keyboard may be removed when an engineer wishes to deny operator access to special engineering functions, or the engineer may carry "his" keyboard to any operating system.

To connect this keyboard, insert the plug on its cable into the small connector located on the side of the operator's keyboard. Note that the plug will only fit one way.

An engineer's keyboard is optionally available, but not supplied with, the optional second, third, or fourth Universal Station.

### 1.1.5 The Local Control Networks

All the nodes in both towers communicate with each other through the TPLCN (Twisted Pair Local Control Network) data communications network, using the RS-485 communications interface standard. This network is similar to the LCN (Local Control Network) used in other TDC 3000<sup>X</sup> equipment, but the noncoaxial RS-485 (twisted pair) network has been chosen here because of its simplicity and the short physical distances between nodes.

High-speed serial data is passed between nodes at 5 megabits per second (mega = million) and follows a token-passing protocol. This protocol is identical to that used on the LCN.

There is a user-installed kit that connects the base Enhanced Micro TDC 3000 to a standard LCN system. The kit includes an LCN cabinet that accommodates 4 or 6 empty chassis; a fan module, power supply, and I/O card for each chassis; Winchester Disk Adapter (WDA) Module; and History Module. Refer to subsection 2.9 for additional information on the LCN upgrade.



## 1.2 OPERATING PRACTICES AND HOUSEKEEPING

Listed here are some do's and don'ts pertaining to operating practices and general housekeeping that should be followed during startup and normal everyday operations.

### 1.2.1 Before Startup

1. Thoroughly clean all operating areas, subfloor areas, cable raceways, heating and air-conditioning ducts, and plenums.
2. Make sure that all control-room windows are sealed.
3. Place impregnated mats at each entrance to a control area to prevent dirt and dust from being tracked in.
4. Provide a coat rack and/or closet outside the operating area for removal of any outer clothing made of nylon or other synthetic fabrics, except where flame-retardant uniforms are mandatory at all times.
5. Make sure that the furniture and carpets are not made of materials that can combine with clothing to create static electricity.
6. Prepare a regular cleaning schedule for specific area requirements and for cleaning of consoles, cabinets, and peripheral devices where necessary. (Caution: Do not attempt to clean the printed-wiring boards themselves.)
7. Establish a "no-smoking" rule in the operating area. Smoke and other fine dust particles can damage cartridge disks and drives.
8. When swapping or handling printed-circuit cards, use a static-control device, such as a wrist strap; see *Circuit Card Handling*, subsection 1.3 of this manual.

### 1.2.2 After Startup

1. Continue your "no-smoking" rule in the operating area. Smoke and fine dust particles can damage cartridge disks and drives.
2. Maintain humidity levels (ideally) between 40 and 60% (lower humidity may cause static-discharge problems).
3. Control humidity fluctuations to a rate-of-change less than 6% per hour.
4. Do not defeat temperature and humidity controls by opening doors and windows (for example, to enhance operator comfort).
5. Keep traffic in the control-room operating areas to a minimum. Restrict access to authorized personnel, whose duties require control room entry.
6. Review procedures for extinguishing electrical fires and establish fire-fighting procedures. Refer to a qualified fire-fighting systems contractor for assistance.

7. Plant personnel frequently use hand-held radios ("walkie-talkies"), or citizens-band radios mounted in maintenance vehicles, for communications. To avoid RFI problems, review the following:
  - If radio communications must take place within an operating area or process controller area, a base-station transceiver with an external antenna should be used.
  - For other applications, radio transmitters with outputs rated as high as 5 watts must be kept at least 3 meters (10 ft.) from the Enhanced Micro TDC 3000 equipment during operation. Transmitters with outputs higher than 5 watts must be kept as far as possible from your equipment. Keep equipment doors closed while operating.

Other sources of RFI include generators, arcing relays, or motor contacts, etc.

8. Follow proper cleaning procedures when cleaning the operator area or the control room:
  - Do not use water freely. Mop should be only dampened, not wet or dry.
  - Use a lint-free, antistatic-type dust cloth to remove dust.
  - Do not sweep around areas containing cartridge disks or drives.
  - Use a vacuum cleaner on carpets—preferably one connected to an external system.
  - Do not allow liquids to be placed on the Enhanced Micro TDC 3000 keyboards and equipment. Liquid spills will damage electronic components.
9. Clean the cartridge disk drive as outlined in the *Universal Station Service* manual in the *LCN Service - I* binder to prevent errors and loss of data when loading programs.
10. Regularly clean the CRT face to minimize operator fatigue. Cleaning procedures are found in *Universal Station Service* manual in the *LCN Service - I* binder.
11. Clean the printer before startup and periodically thereafter, as described in the *Universal Station Service* manual in the *LCN Service - I* binder.
12. Periodically clean the operator and engineer keyboards by dampening a cloth with mild detergent and wiping the keys. Do not spray detergent solution on the keys as moisture may ruin the circuits underneath.
13. Periodically check and clean or replace the air filters in each cabinet. Refer to subsection 6.3.1 of this manual for filter removal and cleaning procedures.

### 1.3 CIRCUIT CARD HANDLING

The circuit cards or Printed Wire Boards (PWBs) are adequately protected from damage caused by Electrostatic Discharge (ESD) only while installed in the system module, or packed inside the conductive plastic bag in which they are shipped. To avoid ESD damage when the card is handled outside its enclosure, to guard against electrical overstress, and to maintain personnel safety, the following practices and procedures must be followed:

- Turn off power to the module before removing or inserting the card.
- Handle the card only by its edges. Do not touch the printed wire board runs, connectors, or components unless you are wearing a grounded wrist-strap and the card is on a conductive work-surface.
- When applying power to the system before installation is complete, terminate all loose wires within the cabinet or console. Make sure power is off when doing any wiring work.
- ESD-generating materials, such as plastic, rubber, nylon, polyester, vinyl, silk, or synthetic materials or garments, should not be allowed in the area of the cards. If you are wearing clothing of such material, you must stand on a grounded floor-mat while wearing a grounded shoe-strap, or you must wear a grounded wrist-strap while handling cards. Note: take special care to always keep the cards away from such material because static charges cannot be drained off, except by discharge.
- Do not carry unprotected cards across carpeting, unless it is grounded conductive carpet such as conventional fiber with woven-in ground wires. Always keep the circuit card in its protective bag until it is actually needed.
- All test equipment and tools must be connected to the metal chassis or module frame with a ground wire, before touching the card or internal wiring.
- Cards must be handled and transported to and from the job site in their protective bags (see approved material list).
- Personnel must wear an approved wrist-strap connected to the chassis before removing the card from its protective bag or card slot.
- When shipping a suspected defective card, pack it in its protective bag before placing it in the shipping carton. Note that cards must be protected against further damage so that failure analysis can be accomplished.
- Do not use standard Bubble Pack mailers.
- Do not allow unprotected cards to come in contact with Styrofoam packing material.

For additional ESD information, refer to the *LCN Planning* manual in the *System Site Planning - I* binder.

## 1.4 CARTRIDGE DISK HANDLING AND STORAGE

Upon receipt of cartridge disks, inspect them for signs of shipping damage. Allow at least one hour for temperature adjustment to the computer-room environment before using.

Recommended storage is on shelves in the computer or control room.

Although the cartridge protects the disk from most accidental damage, the following cartridge handling rules should be observed:

- Do not try to open the cartridge when it is outside the drive.
- Do not insert objects into the cartridge or drive.
- Remove the cartridge from the drive after use and store in its protective jacket.
- Do not expose the cartridge to direct sunlight or moisture.
- Do not expose the cartridge to magnetic fields greater than 30 oersteds.
- Protect the cartridge from dirt, spills, and harsh environments.
- Avoid handling the front edge of the cartridge, since oils can be transferred from the hands to the cartridge disk.

### 1.4.1 Cartridge Loading and Removal

1. Drive power must be on before the cartridge can be inserted. If power to the drive is off, the latch pin in the drive will prevent cartridge insertion.
2. The cartridge is inserted into the drive shutter first. The cartridge edge containing the shutter faces toward the stop button on the front of the drive (see Figure 1-4). Interlocks in the system prevent improper cartridge insertion.

#### CAUTION

If the cartridge is difficult to insert, check its orientation and try again. Do not force the cartridge into the drive. Objects inserted into the cartridge opening in the front of the drive may cause damage to the drive. Such action will void the manufacturer's warranty.

3. After loading a cartridge, the green indicator on the front of the drive, next to the stop button, blinks as the motor is coming up to speed. When the indicator stops blinking and stays lit, the drive is READY (see Figure 1-4).

**NOTE**

The yellow LED flashes briefly as the drive reads initialization information from the disk. If the drive fails to initialize correctly, an error condition exists. If this occurs, reinsert the cartridge to ensure proper seating. If this does not correct the problem, the media may require reformatting or the drive may require service (see Figure 1-4).

4. To remove the cartridge, push the stop button. The green LED then begins to blink as the motor spins down. When the motor has stopped, the green LED turns off and the latch pin disengages. The cartridge can now be removed (see Figure 1-4).

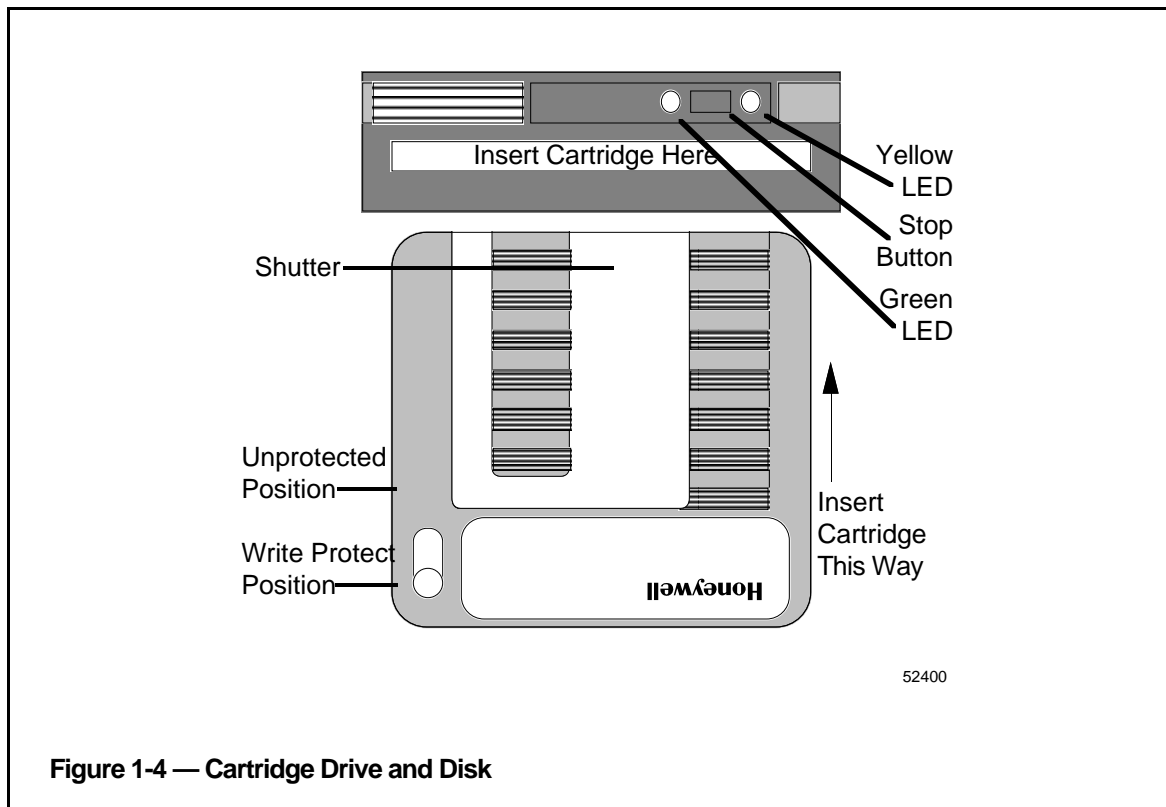

## 1.4.2 Cartridge Media Protection

To protect stored media (programs and data) on a cartridge from being accidentally erased, you must move the protect switch (lower left in Figure 1-4) to the write protect position.

### CAUTION

DON'T attempt to move the protect switch on the cartridge while the cartridge is installed in the drive.

If the protect switch is moved to the unprotected position, the cartridge is free to be written on by the Enhanced Micro TDC 3000 system—data and programs may be lost.

## 1.5 EMC DIRECTIVE

The Enhanced Micro TDC 3000 system is being brought into compliance with European guidelines for ElectroMagnetic Compatibility (EMC). The European EMC directive (89/366/EEC) requires that an electronics product operate reliably in its intended EMC environment. It also requires that the product not detrimentally affect other products operating in their own environment.

Eventually the Enhanced Micro TDC 3000 hardware will display a product certification label to indicate the hardware is in compliance. This label is placed inside, at the bottom front of the tower. As shown in Figure 1-5, a “CE” logo on the product label indicates the product is in compliance with the European EMC directive along with other descriptive information about the product.

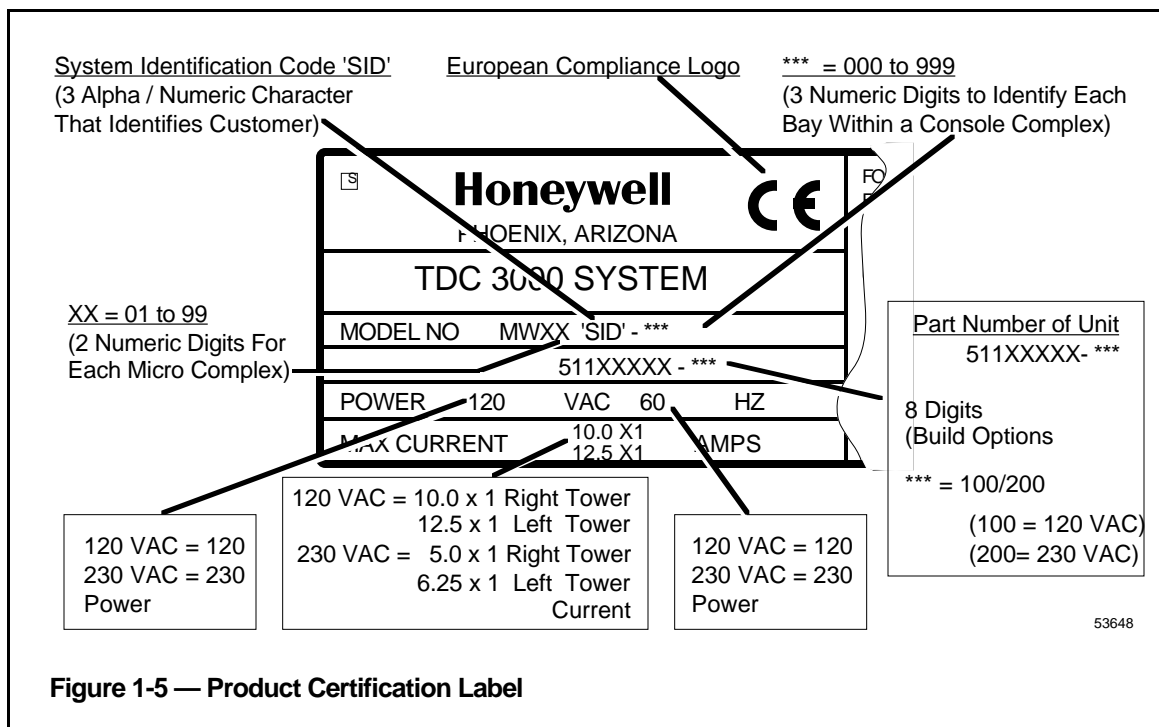

Figure 1-5 — Product Certification Label

## 1.6 RELATED PUBLICATIONS

The following publications apply to the Enhanced Micro TDC 3000 system and should be referred to as required and available:

Title	Binder
8 Node Enhanced Micro TDC 3000 Specification and Technical Data	System Summary - 2
8 Node Enhanced Micro TDC 3000 User's Manual [this pub]	Implementation/8-Node Enhanced Micro TDC 3000
8 Node Multinode Module Service	Implementation/8-Node Enhanced Micro TDC 3000
History Module Service	LCN Service - 2
System Maintenance Guide	LCN Service - 1
Test System Executive	LCN Service - 3
Hardware Verification Test System	LCN Service - 3
Core Module Test System	LCN Service - 3
Maintenance Test Operations	LCN Service - 1
Process Operations Manual	Operation/Process Operations
Universal Control Network Planning	System Site Planning - 1
Universal Control Network Installation	Installation/Universal Control Network
Universal Control Network Guidelines	Installation/Universal Control Network
Universal Control Network Specification and Technical Data	System Summary - 2
PM and APM Planning	System Site Planning - 1
Process Manager/Advanced Process Manager Installation	Implementation/PM/APM
Process Manager/Advanced Process Manager Implementation Guidelines	Implementation/Advanced Process Manager - 1
Process Manager/Advanced Process Manager Checkout	Implementation/PM/APM
Process Manager/Advanced Process Manager Service	PM/APM/HPM Service -1
Process Manager Module Test System (PMMTS)	PM/APM/HPM Service -2
Process Manager Test System (PMTS)	PM/APM/HPM Service -2
Process Manager Test Executive (PMEX)	PM/APM/HPM Service -2

Title	Binder
Enhanced Programmable Logic Controller Gateway Planning, Installation, and Service	Implementation/EPLC Gateway
Enhanced Programmable Logic Controller Gateway Specification and Technical Data	System Summary - 2
Enhanced Programmable Logic Controller Gateway Control Functions	ImplementationE/PLC Gateway
Enhanced Programmable Logic Controller Gateway Parameter Reference Dictionary	Implementation/EPLC Gateway
Enhanced Programmable Logic Controller Gateway Forms	Implementation/EPLC Gateway
MTX-MTLU11 Upgrade Kit Installation Instructions	Not Applicable
MTX-MTLU12 Upgrade Kit Installation Instructions	Not Applicable
MTX-MTLU13 Upgrade Kit Installation Instructions	Not Applicable
MTX-MTLU14 Upgrade Kit Installation Instructions	Not Applicable



## SITE PREPARATION AND INSTALLATION

### Section 2

*This section provides the following information for the Enhanced Micro TDC 3000 Control System: Storage conditions, site requirements, electrical requirements, unpacking, cabling, and node addressing.*

#### 2.1 STORAGE CONDITIONS

The Enhanced Micro TDC 3000 Control System is protectively wrapped for shipment in a dry-wall pack. The electronics modules, color monitor, operator's keyboard, engineer's keyboard, touchscreen, trackball, and printer are in separate packages.

If the Enhanced Micro TDC 3000 Control System is to be placed in storage, the environmental constraints listed here must be followed:

Temperature	-10° + 70°C
Humidity (RH)	10 - 80%, max wet bulb 20 - 30°C
Shock*	3.0 g for 10 milliseconds

\* When enclosed in the original shipping container.

Note that the temperature/relative humidity shall not be cycled such that moisture condensation occurs on the equipment—rate of change less than 6% per hour. The storage shipping requirements are for one year duration only, provided the equipment is properly packaged and contains an adequate amount of desiccant (moisture removing agent).

#### 2.2 SITE REQUIREMENTS

The Enhanced Micro TDC 3000 Control System is designed for a Class C (office) environment. It must be operated in a temperature environment of 0°-45°C (32°-113°F). While operating, components of this system are not designed to withstand greater vibration than:

5-22 Hz	0.254 mm (0.010 inch) displacement
22-500 Hz	0.25 g

For US systems, each electronics module, the monitor(s), and the printer are equipped with 1.8 meter (6 foot) NEMA 5-15P, power cords. For the basic Enhanced Micro TDC 3000 System (refer to subsection 1.1.1), there must be at least two duplex, 120 Vac, grounded, NEMA 5-15R, electrical outlets accessible to these items. These outlets must be tied to the same ground.

If your system is equipped with additional color monitors, there must be at least three duplex, 110 Vac, grounded, NEMA 5-15R, electrical outlets, all tied to the same ground. Additional outlets are also needed if certain options are installed—for example, the EPLCG option may use a free-standing modem powered from 110 Vac lines.

International models (240 Vac) of the Enhanced Micro TDC 3000 Control System are equipped with 1.8 meter (6 foot) power cords having CEE-7 standard VII dual earthing plugs. Likewise, there must be four (or more) CEE-7 standard VII dual earthing electrical outlets provided, all tied to the same ground.

### 2.2.1 Dimensions and Weight

These are the approximate dimensions and weight for each electronics tower, color monitor, UCN cabinet (APM) and printer:

<b>Electronics Tower (each)</b>			<b>Advanced Process Manager (Dual-Access)</b>		
Height	72 cm	(28.3")	Height	210 cm	(81.5")
Width	32 cm	(12.6")	Width	80 cm	(31.5")
Depth	58 cm	(22.8")	Depth	80 cm	(31.5")
Weight	45 kg	(99.2 lb)	Weight	200kg	(440 lb)
<b>Printer (ASPI-41)</b>			<b>Color Monitor (20")</b>		
Height	17 cm	(6.7")	Height	44.9 cm	(17.7")
Width	62 cm	(24.4")	Width	49.8 cm	(19.6")
Depth	31 cm	(12.2")	Depth	53.4 cm	(21.0")
Weight	14 kg	(30.8 lb)	Weight	29 kg	(63.9 lb)
<b>IDEK Color Monitor (21")</b>			<b>HITACHI Color Monitor (21")</b>		
Height	47.1 cm	(18.5")	Height	47 cm	(19.7")
Width	49.2 cm	(19.4")	Width	50 cm	(18.5")
Depth	53.6 cm	(21.1")	Depth	51 cm	(20.1")
Weight	33 kg	(72.7 lb)	Weight	34 kg	(74.9 lb)

For Advanced Process Manager dimensions and weight, consult *Process Manager /Advanced Process Manager Planning*, part of the *System Site Planning - 1* binder.

## 2.3 ELECTRICAL REQUIREMENTS

The customer selected ac power option is installed in the Enhanced Micro TDC 3000 Control System before shipment.

The inrush current to each electronics module is limited to 15 A @ 120 V.

### 2.3.1 AC Voltage Options

120, 240 Vac +10%, -15%

### 2.3.2 Frequency

47 Hz to 63 Hz

### 2.3.3 Current in Amperes at 120 Vac

		Avg	True RMS	Peak	Wattage	BTUs/hr
Twr #1 (1 US, AM, NIM, & drives)	typical	1.65	3.53	10	266	907.06
Twr #1 (2 US, AM, NIM, & drives)	typical	1.95	4.12	11.2	319	1087.79
Twr #1 (1 US, AM, NIM, CG, & drives)	typical	2.01	4.25	11.4	329	1121.89
Twr #2 (HM only)	typical	1.15	2.54	6.5	185	630.85
Twr #2 (HM & US)	typical	1.54	3.34	9.5	249	849.09
Twr #2 (HM, US, & US)	typical	1.84	3.91	10.7	299	1019.59
Twr #2 (HM, US, & CG)	typical	1.95	4.12	11.2	319	1087.79
Monitor, 20 inch CRT	typical	0.5	1.14	3.1	79	269.39
Monitor, 21 inch CRT	typical	0.8	1.5	4.1	83	283
ASPI-41 Printer	typical	1.1	1.75	9.1	210	716

For Advanced Process Manager power consumption, consult *Process Manager /Advanced Process Manager Planning*, part of the *System Site Planning - I* binder.

## 2.4 UNPACKING

When the equipment arrives at the system site, open each shipping box, remove the protective wrapping and carefully inspect each piece for any physical damage. If damaged, immediately notify the carrier and your Honeywell sales representative as to the extent and type of damage. Also check each piece of equipment against the invoice list for any missing items.

### CAUTION

Optional touchscreens will be factory installed. Be careful not to lift the CRTs by holding the touchscreen bezel. Due to the weight you may easily damage the touchscreen.

## 2.5 SITE LAYOUT

Figure 2-1 shows a typical installation of the Enhanced Micro TDC 3000 System in a minimum-sized 4 meter x 4 meter (13.1 foot x 13.1 foot) area. Allow a minimum of one meter (3.3 feet) behind and to the side of the equipment for cabling and service.

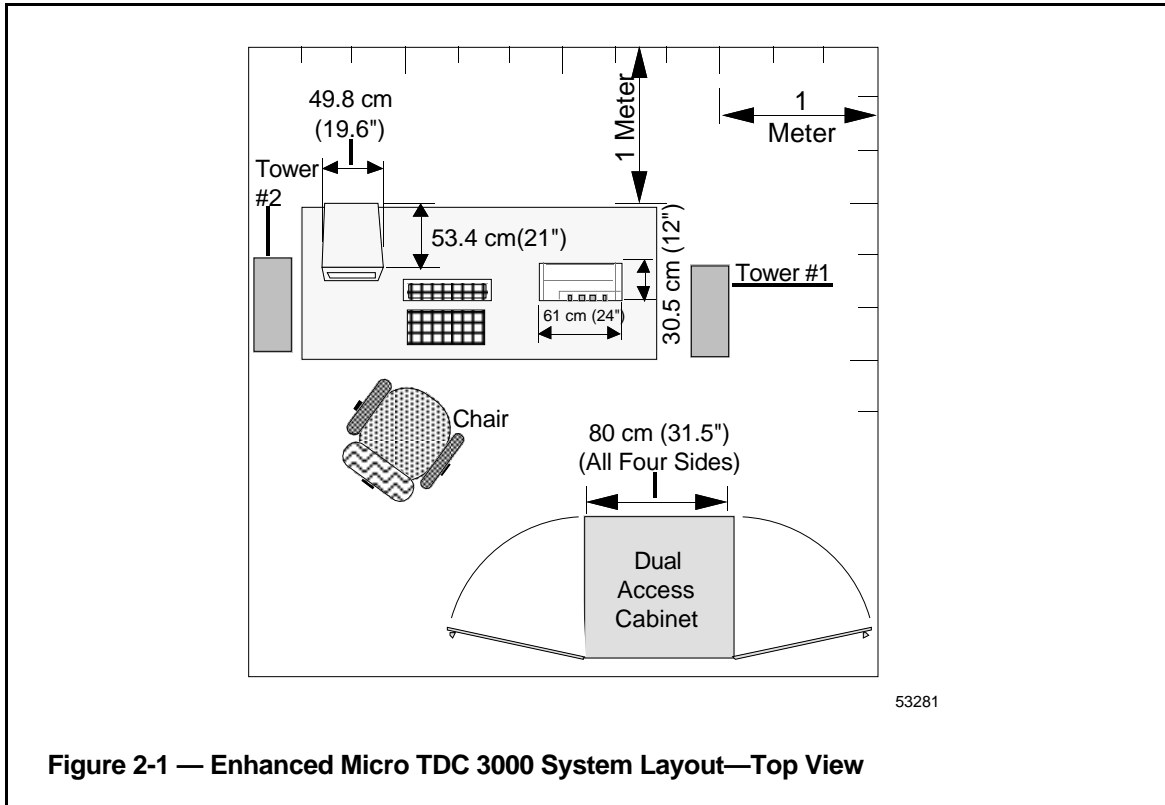

**Figure 2-1 — Enhanced Micro TDC 3000 System Layout—Top View**

The dual access Advanced Process Manager cabinet is included with the Enhanced Micro TDC 3000 System and is shown for reference in Figure 2-1. Complete planning and installation instructions for the Advanced Process Manager are given in the *Process Manager/Advanced Process Manager Planning*, part of the *System Site Planning - 1* binder and *Process Manager/Advanced Process Manager Installation* manual, part of the *Implementation/PM/APM* binder.

## 2.6 INSTALLATION

### WARNING

DO NOT apply power to any of the Enhanced Micro TDC 3000 Control System equipment until this installation is completed and this manual tells you to do so. Be sure the power switches are OFF on all equipment and that no power cords are plugged into electrical ac mains.

Failure to heed this caution may subject personnel to severe electrical shock or cause permanent damage to the equipment.

In the following steps, you will move relatively heavy and bulky units containing sensitive electronic equipment. When moving a tower, we recommend you use two people to place the tower on a low, flat, roller dolly for transfer within the building. If a hand-truck is used, it must be well-padded and you must use care not to put excessive stress on the short feet under the tower.

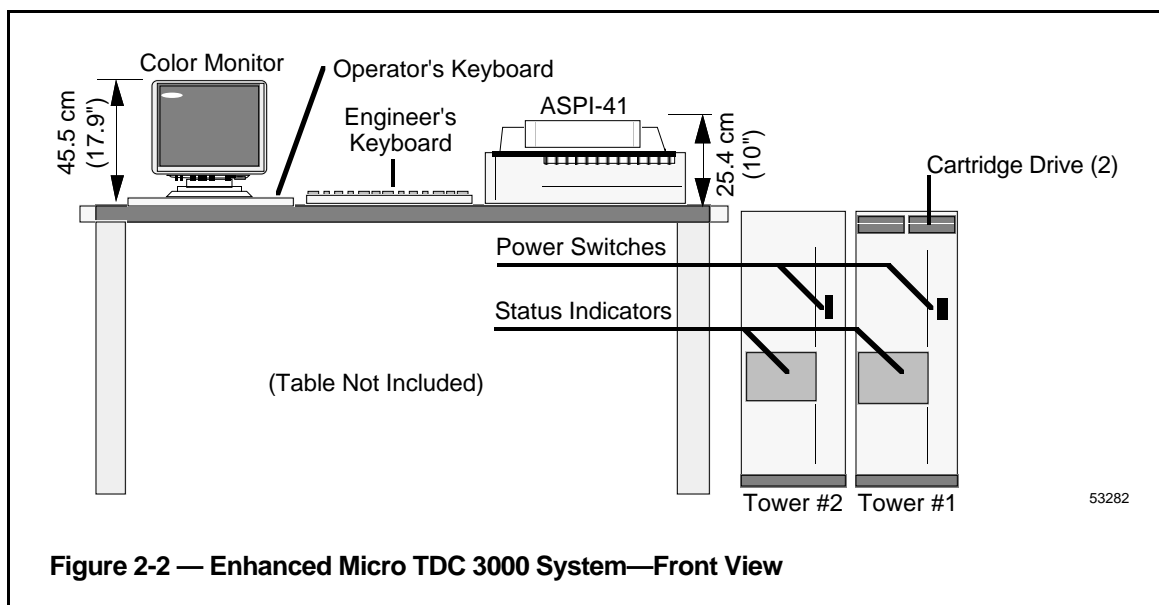

**Figure 2-2 — Enhanced Micro TDC 3000 System—Front View**

1. First, identify the electronics cabinets. These cabinets (towers) are shown in Figure 2-2 (and in Figure 2-1 with shaded lines). The towers look nearly identical, with a translucent panel and a power switch near the middle-front of each cabinet. Tower #1 can be identified by two black cartridge drives installed near the top-front of its cabinet. Tower #1 is also referred to as the “right 4-node” tower; tower #2 as the “left 4-node” tower.
2. Do not place Color Monitors closer than 12” to each other.
3. Using Figures 2-1 and 2-2 as examples, place the towers in position, parallel to each other. The printer must be positioned near tower #1 for connection to US #1, but within the 6 foot length of the printer cable. Put the towers within 84 cm (33”) apart (unless you have the optional 10 meter cable). Make sure both towers sit firmly on level flooring.

## 2.7 TOWER #1 EQUIPMENT CABLING

### CAUTION

Before removing the rear panel of either tower, ensure that all power switches are OFF and that the power cords are unplugged.

You will now electrically connect the electronics cabinets (towers) together, and to their peripherals, with a variety of signal cables. Refer to Figures 2-3, 2-4, 2-5, and 2-6 for the location(s) of the connectors mentioned.

The following subsections, where applicable, may contain information on the EMC Directive that affects the hardware. When applicable, the EMC hardware information will usually follow the hardware that is not in compliance with the directive.

### NOTE

No instructions are given in this section for peripheral equipment that has been factory mounted within a tower, such as Cartridge Drives or the History Module, since they have been fully cabled at the factory. Likewise, no node addressing (pinning) is contained in this section because nodes have been factory pinned.

For replacement board pinning instructions, see Section 6—*Service*, of this manual.

## 2.7.1 Cabling – Standard

1. Remove the rear center-section cover of both towers by removing four M5 flat-head screws, exposing the I/O boards as shown in Figure 2-3. The cards seen in Figure 2-3 are a typical example for Tower #1. Note some connectors are not used and are only outlined in Figure 2-3. The cables from these card connectors to the transition panels, shown in Figure 2-5, will have been installed at the factory.

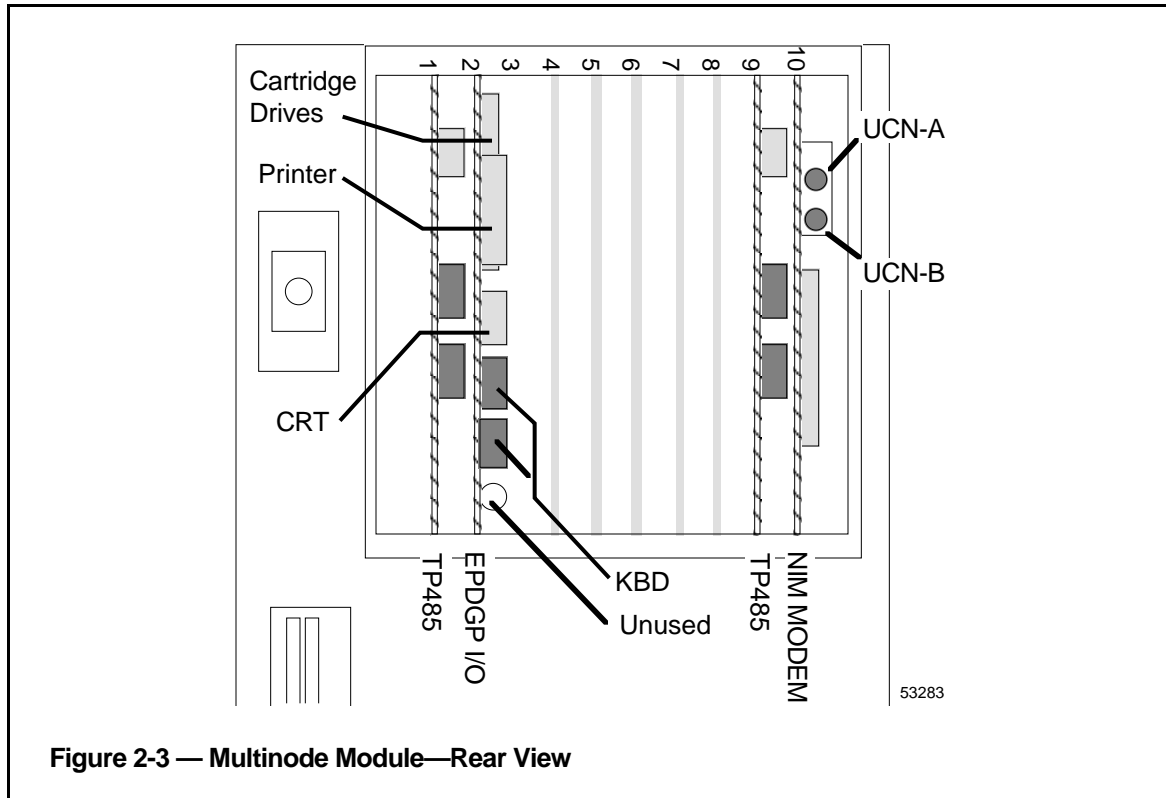

2. Note there are two TP485 cards, in slots 1 and 9. The TP485 in slot 9 of each tower provides the TPLCN interface. The TP485 in slot 1 in each tower provides the connection, at J3 (see Figure 2-4), and interface for thermocouples that sense the module's temperature (non-EC Compliant modules only).

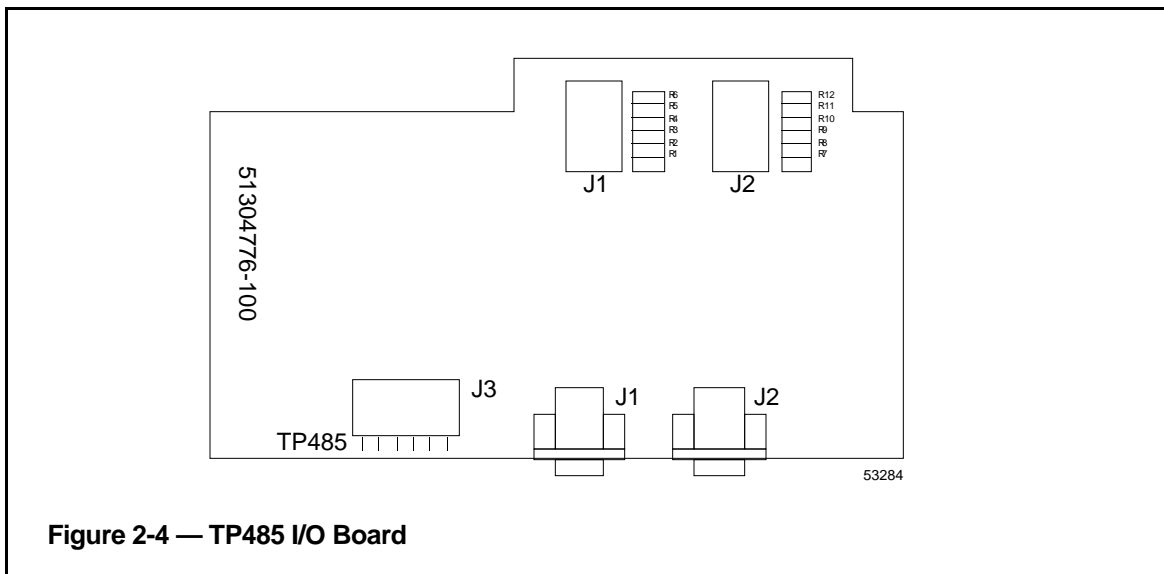

**Figure 2-4 — TP485 I/O Board**

3. The standard cabling connections you will make in the following steps are on the transition panels in Figure 2-5. Note there are two exposed transition panels—one at the top of the center section and another at the bottom (see Figure 2-5). The panel has connectors and cable clamps on it that will be used to secure cables you will install. Both towers have the same locations for specific connector/clamp brackets but the bracket types in certain locations may differ depending on the options installed.

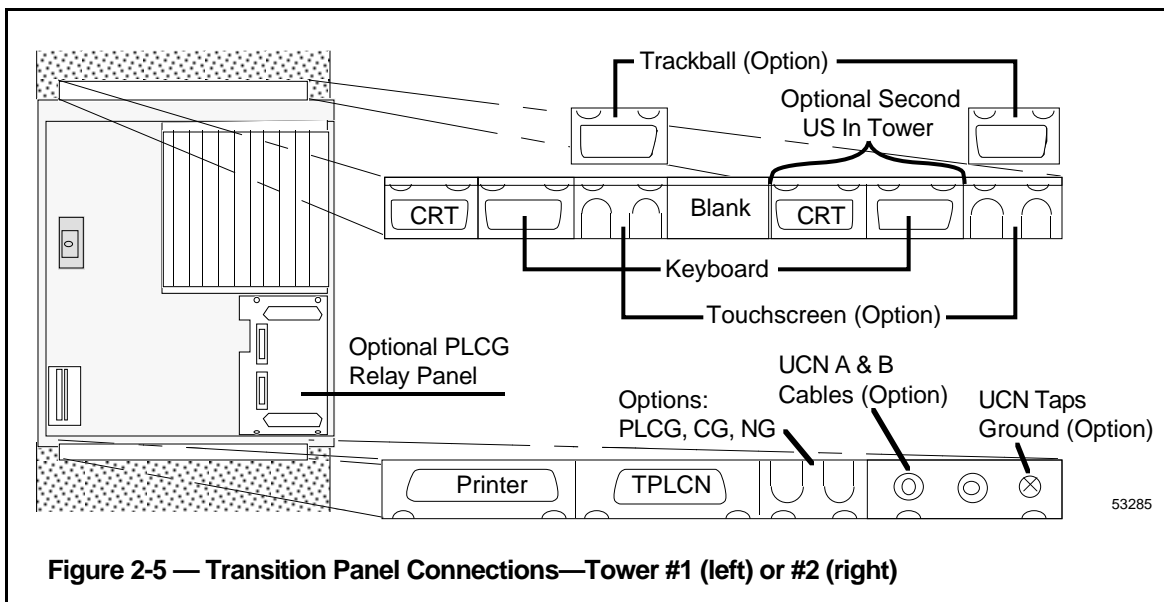

**Figure 2-5 — Transition Panel Connections—Tower #1 (left) or #2 (right)**

4. Note the Optional PLCG Relay Panel in Figure 2-5 above. It can be mounted above the transition panel, as shown, in the tower containing an optional EPLCG (see Section 2.8.5).



## 2.7.2 Cabling – EMC Directive

Generally, EMC Directive cabling on the LCN systems follow these rules:

- any cable exiting an enclosure is shielded
  - cable shields are terminated at both ends of the cable to chassis ground
  - metallic connector housings (back-shells) completely enclose the cable for contiguous shield
  - braid or braid over foil is used on coaxial cables
  - foil is used as a shield where applicable (on multi-pair cables).
1. Remove the rear center-section cover of both towers by removing four M5 flat-head screws, exposing the EMC Directive I/O boards as shown in Figure 2-6. Note that the I/O boards have the face plates attached to the free edge of the board. The face plates are secured to the sheet metal module with screws. The cards seen in Figure 2-6 are a typical example for Tower #1. Note some chassis slots are not used and have filler face plates covering the board slot. The cables from these board face plates to the transition panels will have been installed at the factory.

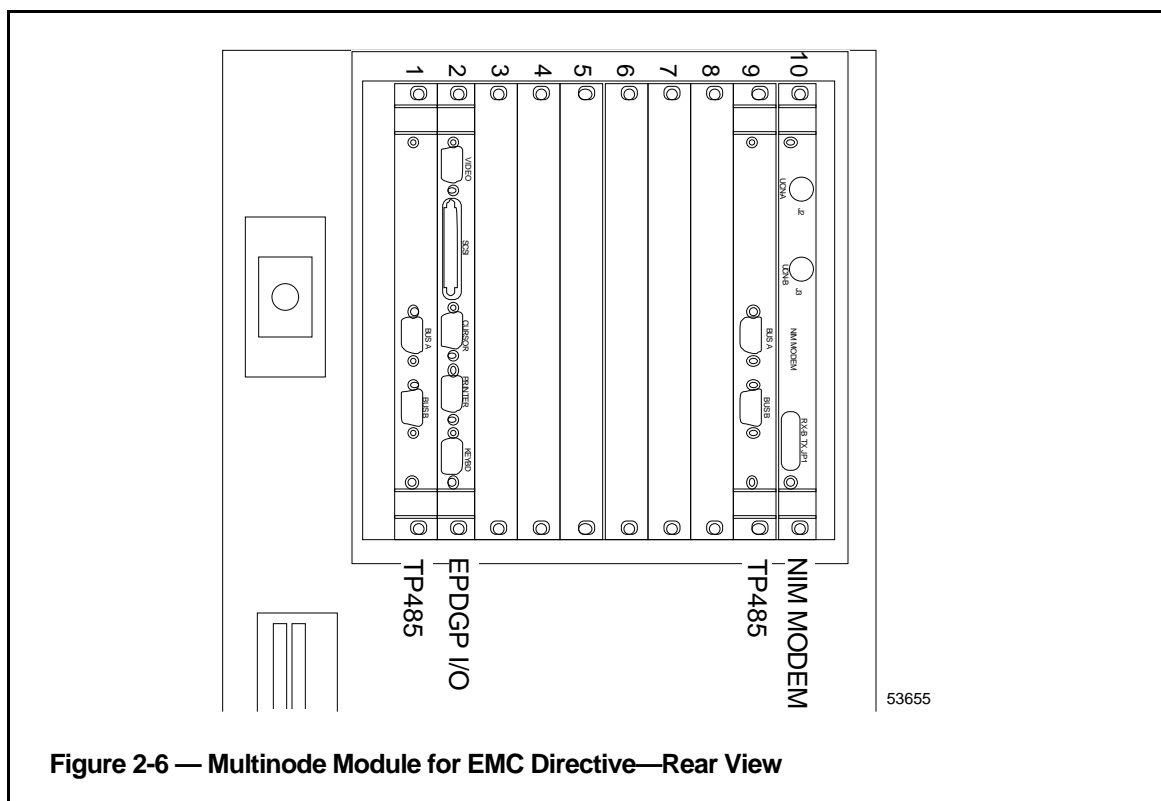

**Figure 2-6 — Multinode Module for EMC Directive—Rear View**

2. Note there are two TP485 cards, in slots 1 and 9. The TP485 in slot 9 of each tower provides the TPLCN interface. The TP485 in slot 1 in each tower provides the connection, at J3 (see Figure 2-4), and interface for thermocouples that sense the module's temperature (non-EMC Directive equipment).

3. For EMC Directive cabling, the connections you will make in the following steps is on the transition panel shown in Figure 2-7. Note there is one exposed transition panel located at the bottom (see Figure 2-7). The panel has connectors and cable clamps on it that will be used to secure cables you will install. Both towers have the same locations for specific connector/clamp brackets but the bracket types in certain locations may differ depending on the options installed.

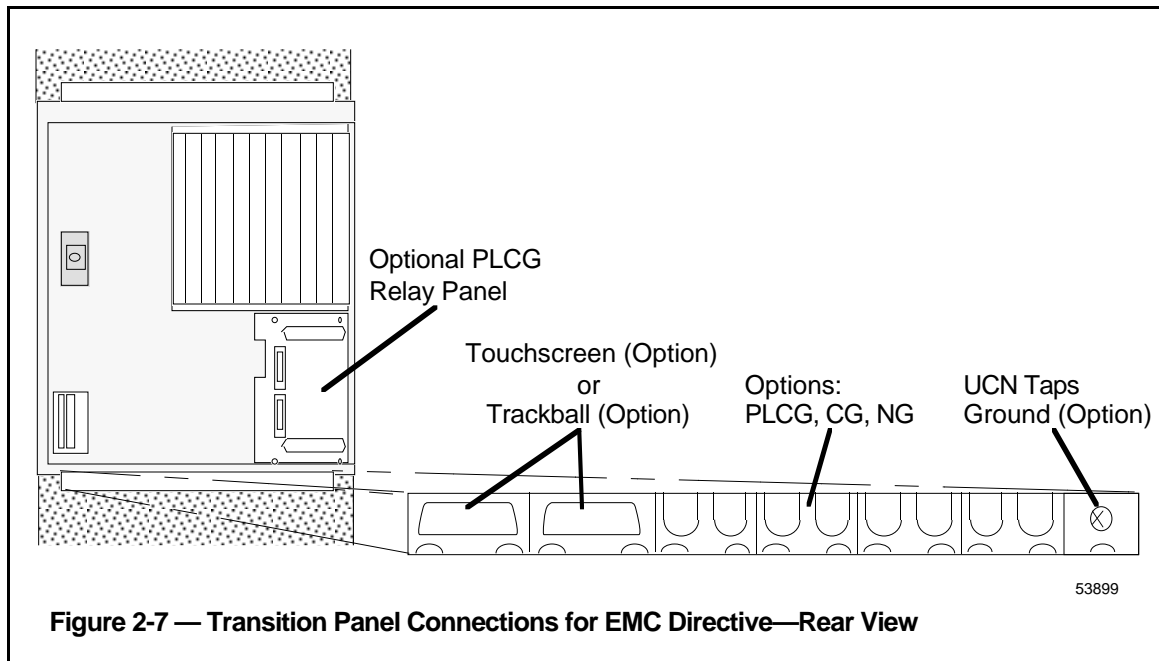

4. Note the Optional EPLCG Relay Panel in Figure 2-5 above. It can be mounted above the transition panel, as shown, in the tower containing an optional EPLCG (see Section 2.8.5).

Figure 2-8 and Figure 2-9 shows the EMC Directive TP-485-3 I/O board face plate. The designed cable(s) attached to this card face plate is also terminated to ground (sheet metal module) through the attaching screw on the face plate. This I/O board provides the current loop interface between the modules located in an Enhanced Micro TDC 3000 tower.

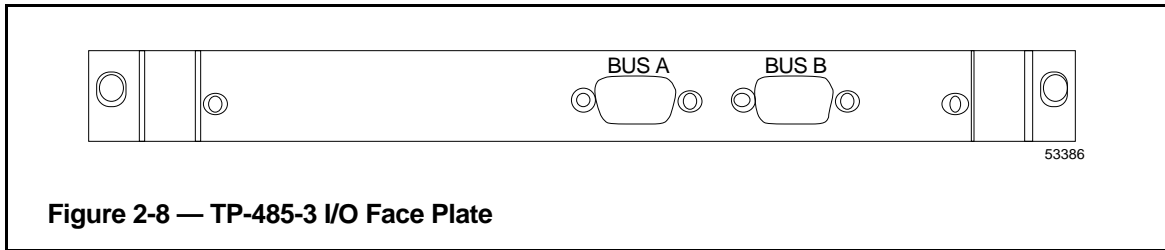

Figure 2-8 — TP-485-3 I/O Face Plate

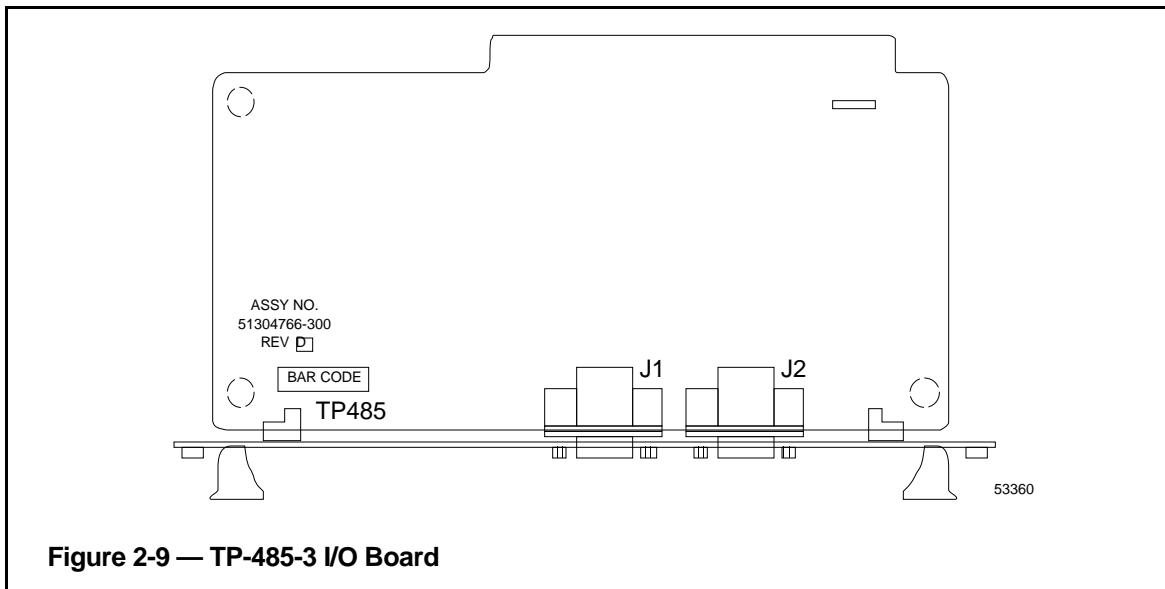
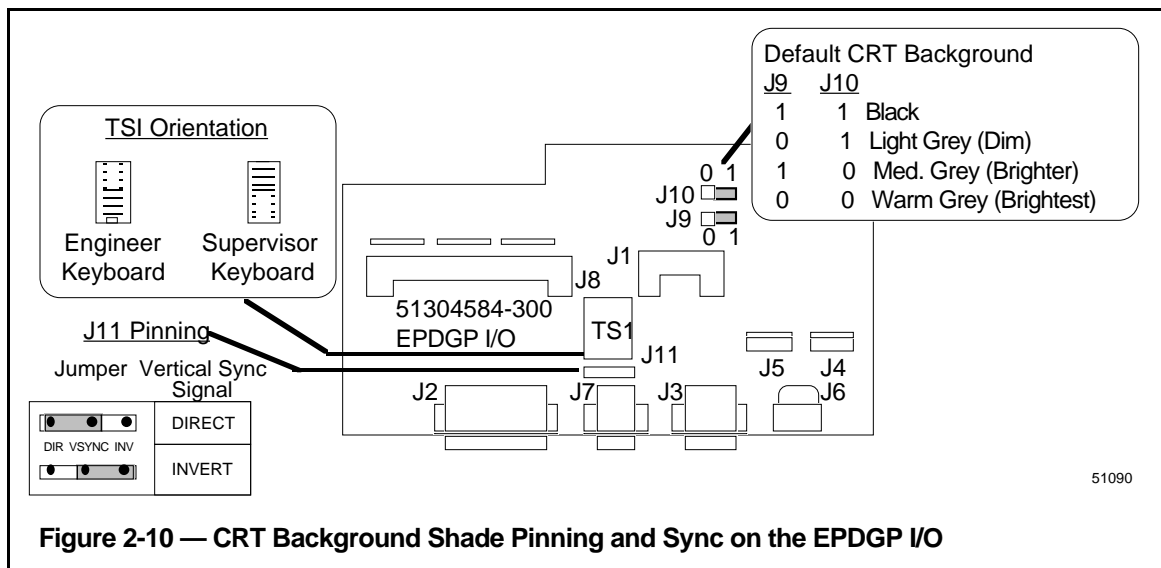

Figure 2-9 — TP-485-3 I/O Board

### 2.7.3 Cabling EPDGP I/O Board

EPDGP I/O boards (see Figures 2-10 and 2-11) interface nearly all the peripherals of the Enhanced Micro TDC 3000 Control System. You are now going to connect those cables which could not be installed at the factory.



EPDGP I/O boards can be pinned for default background shading(J9 and J10) and vertical sync (J11) for the monitor as shown in Figure 2-10.

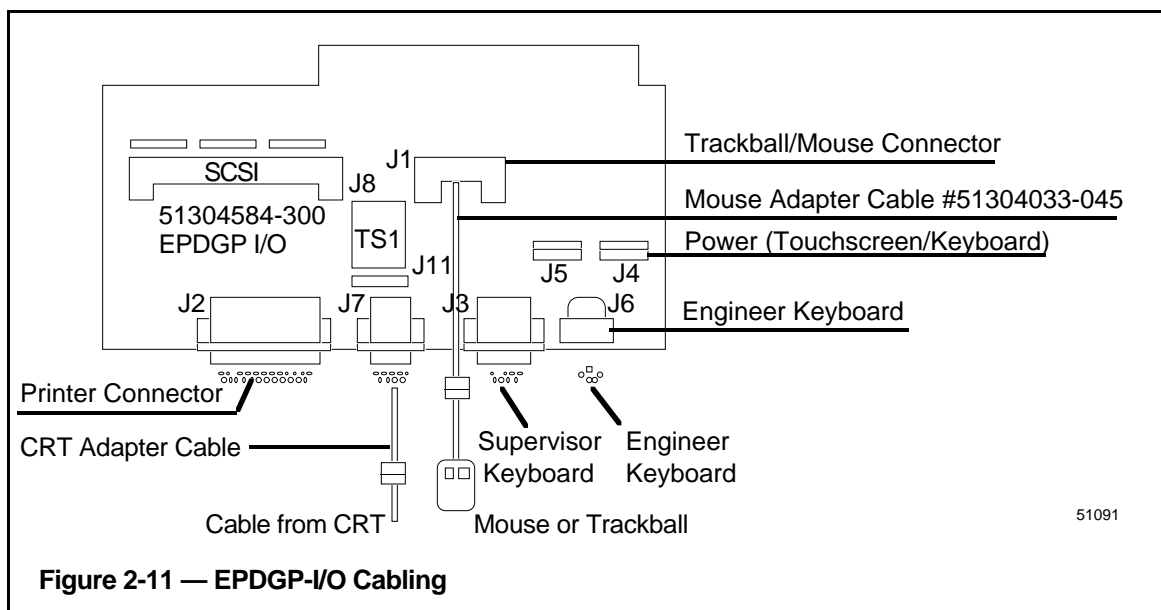

Universal Station Type	EPDGP I/O Assembly
Classic with keyboard power supply	51304584-100
Classic without keyboard power supply	51304584-200
Ergonomic furniture with 21" FST monitor	51304584-300

## 2.7.4 Cabling EPDGC I/O Board

The EPDGC I/O is the EMC Directive board version used to interface with the monitor, keyboard, touchscreen, SCSI cartridge drives and printers. The EMC Directive version is shown in Figures 2-12 and 2-13. All the connectors have been converted to D-type connectors with full 360 degree shielding. The connectors are bulkhead mounted into the board face plate which provides a contiguous shield from module to cable. The cabling of peripheral devices are connected at this face plate. The Touchscreen and Trackball cables are connected to the cabinet bulkhead shown in Figure 2-7.

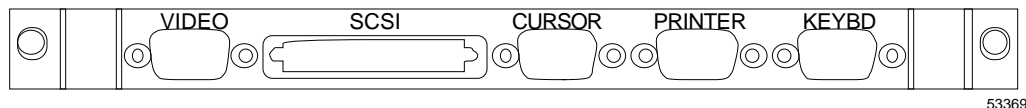

Figure 2-12 — EPDGC I/O Face Plate

The background color of the monitor can be selected as one of four colors as shown in Figure 2-13. The pinning shown is for the default background color. Pin the board for desired background color. The pinned background color selection is only in force until the station is loaded with software.

The sync pulse requirements of the monitor used is pinned at J6 (factory set) as shown in Figure 2-13. The pinning of J6 will determine the tab number of the board and is factory set. The monitor sync pulse source will either be direct (Tab 100) or inverted (Tab 200).

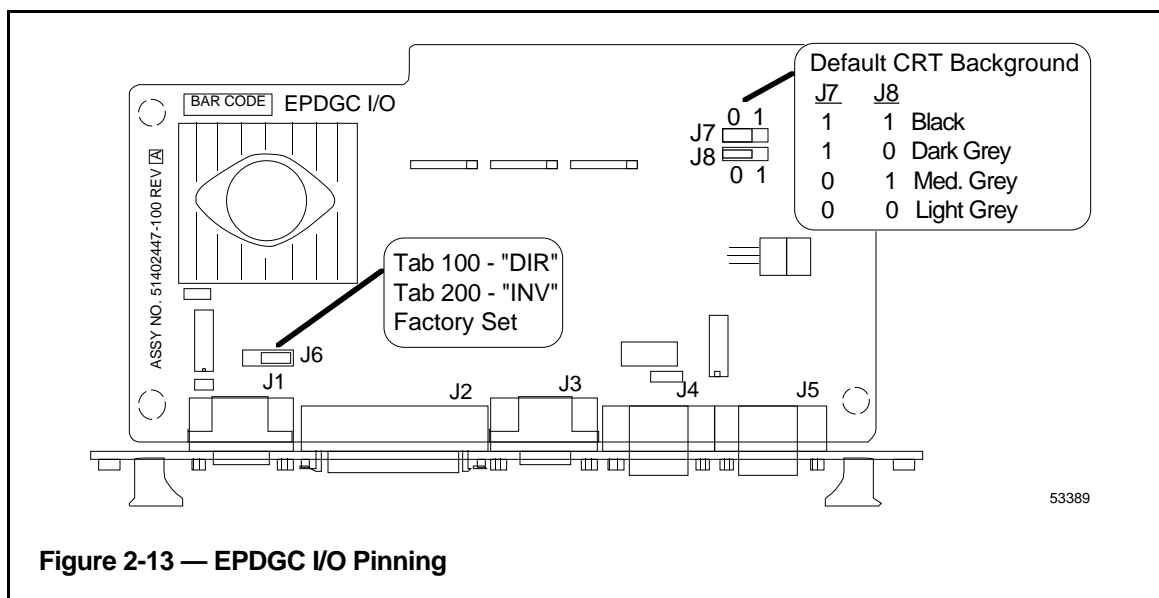

Figure 2-13 — EPDGC I/O Pinning

### 2.7.5 Operator Keyboard Cabling

Connect the keyboard cable to the connector on the face plate of the EPDGC I/O board (see Figure 2-11). Use a small screwdriver to tighten the screws (2) on the connector.

### 2.7.6 Printer Cabling

The printer cable (51303631-003) has similar connectors on each end.

1. Connect the end of the cable marked **PIC** to the connector on the face plate of the EPDGC I/O board marked **PRINTER** in Figure 2-11. Use a small screwdriver to tighten the screws (2) on the connector.
2. Connect the other end of the printer cable (marked **PRINTER**) to the back of the printer. Using a small screwdriver, tighten the screws (2) on the connector.

### 2.7.7 Color Monitor Cabling

Connect the cable from the color monitor to the EPDGC I/O face plate connector marked **VIDEO** in Figure 2-11, on the upper transition panel. Using a small screwdriver, tighten the screws (2) on the connector. Finally, attach the power cord to the monitor and plug it in.

### 2.7.8 Engineer's Keyboard Cabling

Insert the plug on the cable from the engineer's keyboard into the small connector located on the right of the operator keyboard. Note the plug will only fit one way.

### 2.7.9 TPLCN Cabling

The two (2) TPLCN cables (51304505-100) have similar connectors on each end. The standard cable length is 5 feet (1.5 meters). The optional cable (Option number MX-MTLC11) is 33 feet (10 meters) long, allowing a maximum distance between towers of 10 meters. The cable set connects directly to the TP-485 board face plates in the towers.

1. Attach one cable plug to the TP-485 face plate connector marked **BUS A** and the other cable plug to **BUS B** at the rear of Tower #1. Using a small screwdriver, tighten the screws (2) on the connectors.
2. Attach the other end of the cable to the TP-485 face plate connector marked **BUS A** and the other cable plug to **BUS B** at the rear of Tower #2. Use a small screwdriver to tighten the screws (2) on the connectors.
3. Attach the ground wires to the small screws, if they are on your cable.

### 2.7.10 Touchscreen Cabling

The optional Touchscreen and Trackball are not to be used together on the same US, so they share the same connector (J1) on the EPDGP I/O card. When the Trackball or Touchscreen is selected are bulkhead connected at the transition panel (see Figure 2-7).

1. The cables from the optional touchscreen pass through the clamps in the left location marked TOUCHSCREEN on the lower transition panel in Figure 2-5, and are to be connected to the EPDGP I/O card in slot 2 as shown in Figure 2-6.
2. Plug the large connector into J1, marked TOUCHSCREEN or TRACKBALL in Figure 2-6, on the EPDGP I/O card and the small connector into J4, marked POWER in Figure 2-6. The EPDGP I/O card may have to be partially or completely pulled out to make these connections. Use proper board handling precautions, including a grounded wrist-strap, to extract the card. Use care not to disturb or dislodge existing cables and then firmly reseat the card.
3. Using a cable-tie (51190879-001) on each cable, fasten the cables to their strain-relief clamps on the upper transition panel.

### 2.7.11 Trackball Cabling

The cable from the optional trackball is to be connected to the lower transition panel at the left location marked Trackball in Figure 2-5. Use a small screwdriver to tighten the screws (2) on the connector. In accordance with the user's preference, place the trackball either to the right or left side of the keyboard.

### 2.7.12 Process Cabling

#### NOTE

It is not necessary to connect process cabling to the Enhanced Micro TDC 3000 Control System before you turn power on and make the preliminary checks described in Section 3. Skip this section and go on to subsection 2.8 if the process connections are not yet available.

#### CAUTION

Two UCN taps must be mounted within 5 cable meters (15 cable feet) of the UCN connectors on the transition panel (see Figure 2-5). Before you continue with these cabling instructions, be sure you have mounted the UCN trunk and taps in accordance with instructions in the UCN manuals listed in subsection 1.5. Also, be sure the taps and drop cables have been tested and clearly marked "A" and "B" to avoid miswiring.

Use only the UCN drop cables to and within the towers of this equipment. UCN trunk cables are too bulky and lack the appropriate electrical characteristics for proper operation.

Examine the 15 meter drop cables previously connected to the two UCN taps. Note the cables are clearly marked "A" and "B."

1. Connect these UCN cables to their proper connectors on the lower transition panel (see Figure 2-5). **BE SURE "A" AND "B" CABLES CONNECT RESPECTIVELY TO THE "A" AND "B" CONNECTORS** on the panel bracket without cross-connection. If necessary, check the mini-coax cables from the rear of the panel bracket to the NIM MODEM card to allow you to confirm the connections.
2. Route the UCN drop cables from the panel out of the cabinet without making sharp bends or kinks in the cables.
3. Connect a ground wire from the two UCN taps serving this NIM to the screw marked UCN GND in Figure 2-5.
4. The NIM MODEM card has been factory-pinned to UCN address #1. You will verify this address in Section 4 of this manual. Consult UCN manuals listed in subsection 1.5 for installation and pinning of the Advanced Process Manager that this NIM "talks" to. The PMM in that Advanced Process Manager must be pinned for UCN address #3.



## 2.7.13 Cabling Diagram and Parts List —Track Ball

Cabling for the Universal Station is shown in the following figure and table.

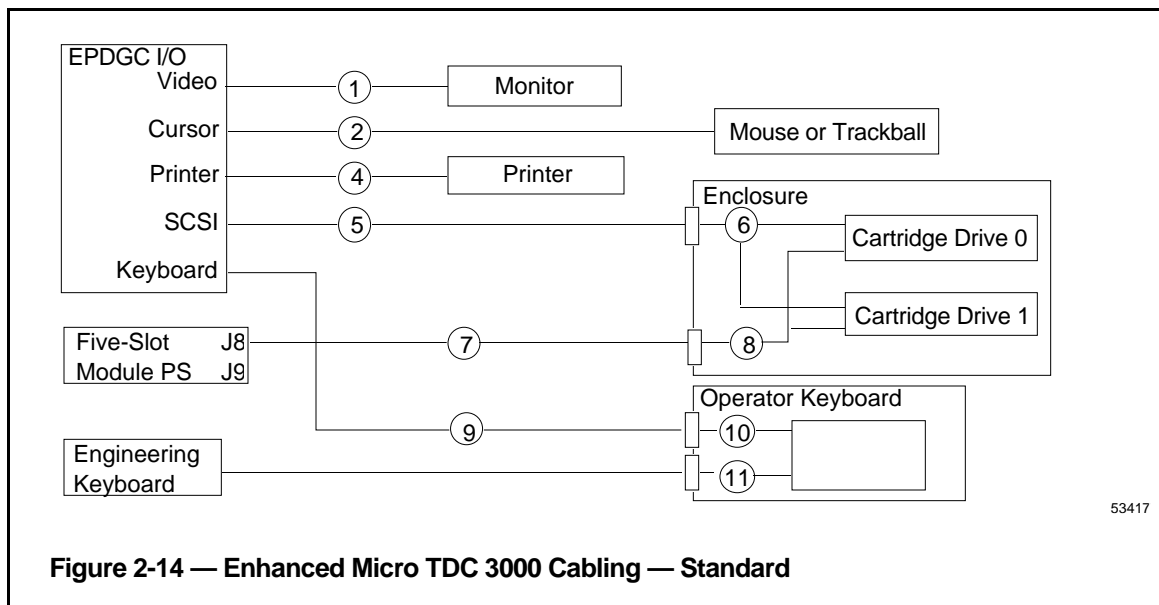
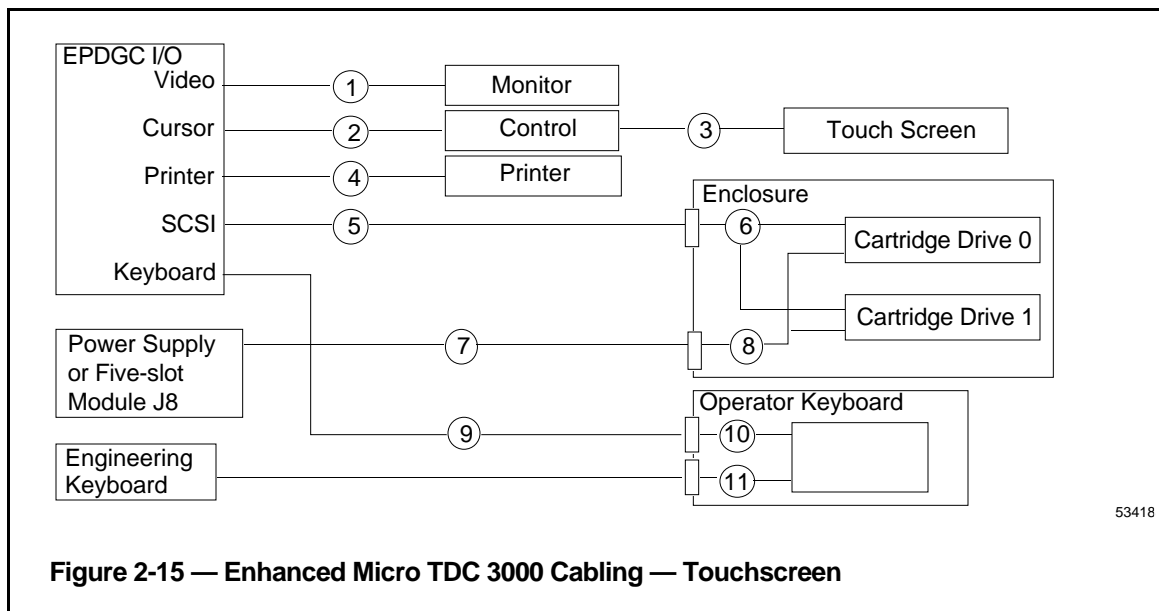

**Table 2-2 — Micro TDC 3000 Cabling — Standard (Trackball)**

Ref. #	Part Number	Application Notes
1	51192126-200	Video Cable
2	51308099-100	Mouse/Trackball Interface Cable
3		Not Applicable
4	51308103-003	Printer Cable – 3 meters/9.8 ft.
	51308103-008	Printer Cable – 8 meters/26.3 ft.
	51308103-015	Printer Cable — 15 meters/49.2 ft.
5	51192054-101	Cable,SCSI Shielded, 50 position
6	51305070-200	Cable, SCSI
7	51308110-100	Cartridge DC Power Cable
8	51308109-100	Cartridge DC Power Cable (in Enclosure)
9	51308105-200	Keyboard Interface Cable
10	51308104-100	Keyboard Interface Cable (in Keyboard Tray)
11	51304496-046	Engineer"s Keyboard Cable (in Keyboard Tray)

## 2.7.14 Cabling Diagram and Parts List – Touchscreen

If the touchscreen special has been installed, the following figure and table represents the cabling.



**Table 2-3 — Micro TDC 3000 Cabling — Touchscreen**

Ref. #	Part Number	Application Notes
1	51192126-200	Video Cable
2	51308097-100	Touchscreen Interface Cable
3	51308114-100	Touchscreen Interface Cable
4	51308103-003	Printer Cable – 3 meters/9.8 ft.
	51308103-008	Printer Cable – 8 meters/26.3 ft.
	51308103-015	Printer Cable – 15 meters/49.2 ft.
5	51192054-101	Cable,SCSI Shielded, 50 position
6	51305070-200	Cable, SCSI
7	51308110-100	Cartridge Drive Power Cable
8	51308109-100	Cartridge Drive Power Cable (in Enclosure)
9	51308105-200	Keyboard Interconnecting Cable
10	51308104-100	Keyboard Interface Cable (in Keyboard Tray)
11	51304496-046	Engineer"s Keyboard Cable (in Keyboard Tray)

## 2.8 TOWER #2 EQUIPMENT CABLING

If your Enhanced Micro TDC 3000 System has one color monitor and no options except a touchscreen or trackball, there is no further cabling to be done on tower #2. Skip this section and proceed with subsection 2.10, Installation Wrap-Up.

If you have a second Universal Station or additional options, consult the paragraphs in this section that deal specifically with those options and cable them accordingly.

The following subsections, where applicable, may contain information on the EMC Directive that affects the hardware. When applicable, the EMC hardware information will usually follow the hardware that is not in compliance with the directive.

### 2.8.1 Optional Universal Station Upgrade

Adding this kit upgrades a basic Enhanced Micro TDC 3000 System. This involves adding a Universal Station node containing K2LCN, EPDG2, EPDGC I/O boards, and keyboard. The monitor is ordered separately. Refer to *MX-MTUS34* or *MX-MTUS36 Upgrade Kit Installation Instructions* for directions for upgrade.

### 2.8.2 Optional Redundant Network Interface Module

The redundant NIM, in conjunction with a redundantly-connected Advanced Process Manager, provides a level of protection in case of equipment failure.

#### NOTE

It is not necessary to connect process cabling to the Enhanced Micro TDC 3000 Control System before you turn power on and make the preliminary checks described in Section 3. Skip this section and go on to subsection 2.8.3 if the process connections are not yet available.

1. Remove the rear center-section cover of tower #2 and connect the pair of UCN drop cables for this redundant NIM to the NIM MODEM card in a similar manner to that used to connect the first pair to the primary NIM in tower #1 (subsection 2.7.8). **BE SURE "A" AND "B" CABLES CONNECT RESPECTIVELY TO THE "A" AND "B" CONNECTORS** on the board or card without cross-connection. There is a separate ground wire that connects the building ground to each UCN tap.
2. Firmly reinstall the card. Route the UCN cables from the card out of the cabinet without making sharp bends or kinks in the cables. Using a cable-tie (51190879-001) on each cable, fasten the UCN cables to their strain-relief clamps (marked UCN CBL in Figure 2-5) on the lower transition panel of Tower #2.
3. The NIM MODEM card in this redundant NIM has been factory-pinned to UCN address #2. You will verify this address in Section 4 of this manual. Consult UCN manuals listed in subsection 1.5 for installation and pinning of the Advanced Process Manager that this NIM “talks” to. Pinning for the odd address for the first PMM yields the even address for the redundant PMM automatically.

### 2.8.3 Optional Computer Gateway CLI I/O

The optional computer gateway adds one or two connections to a host computer.

1. Remove the rear center-section cover of tower #2 and connect the computer cable (503790-xxx) to **JA** of the CLI I/O board (see Figure 2-16). Use a small screwdriver to tighten the screws (2) on the connector.

The tab number (-xxx) in the cable drawing number refers to its length in meters. The maximum cable length is 305 meters (1000 feet).

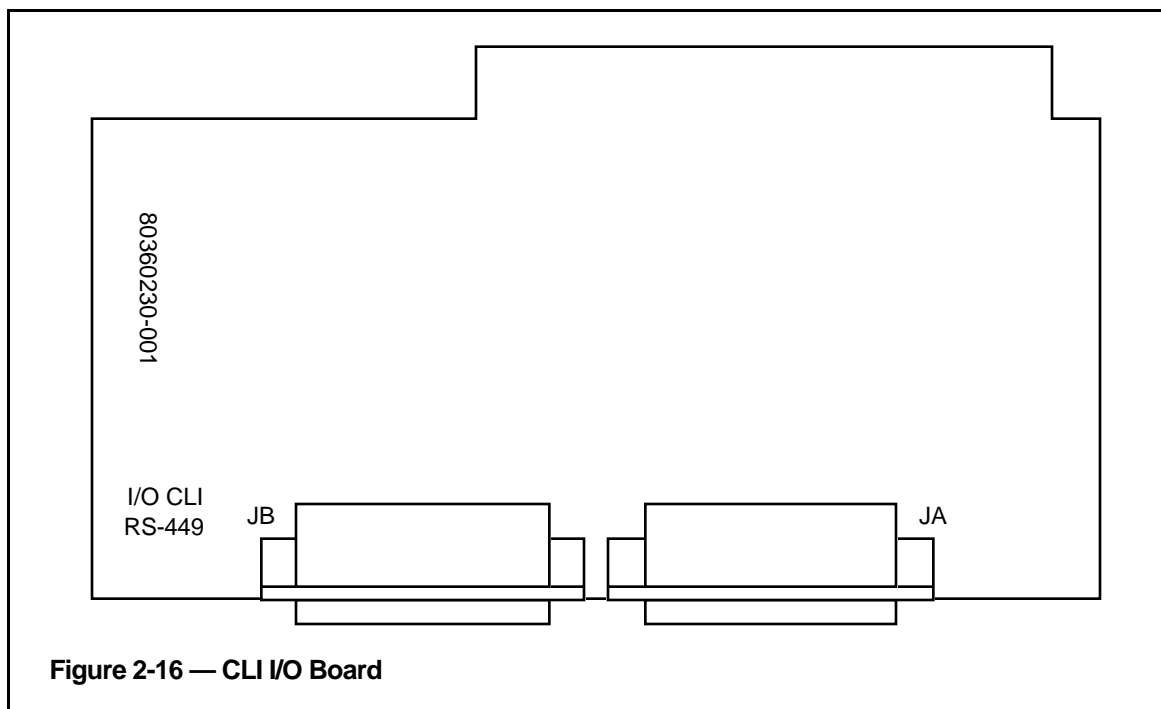

2. If the host computer is running in a redundant mode, an additional cable must be connected from the computer to **JB** of the CLI I/O board (see Figure 2-16). Use a small screwdriver to tighten the screws (2) on the connector.
3. Using a cable-tie (51190879-001) on each cable, fasten the cables to their strain-relief clamps (marked OPTIONS in Figure 2-7) on the lower transition panel.

## 2.8.4 Optional Computer Gateway CLI/A I/O

The optional computer gateway adds one or two connections to a host computer. Figure 2-17 and Figure 2-18 show the physical characteristics of the Computer Gateway I/O board designed to follow the EMC Directive. The board design remains the same as the old version. A bulkhead face plate is added to the PWA and supports the two D-type connectors. The cables are changed to braid over foil shield with 360 degree metalized plastic back-shells.

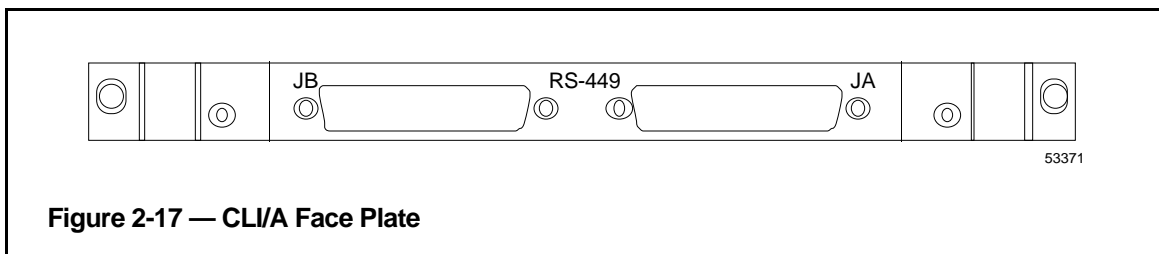

Figure 2-17 — CLI/A Face Plate

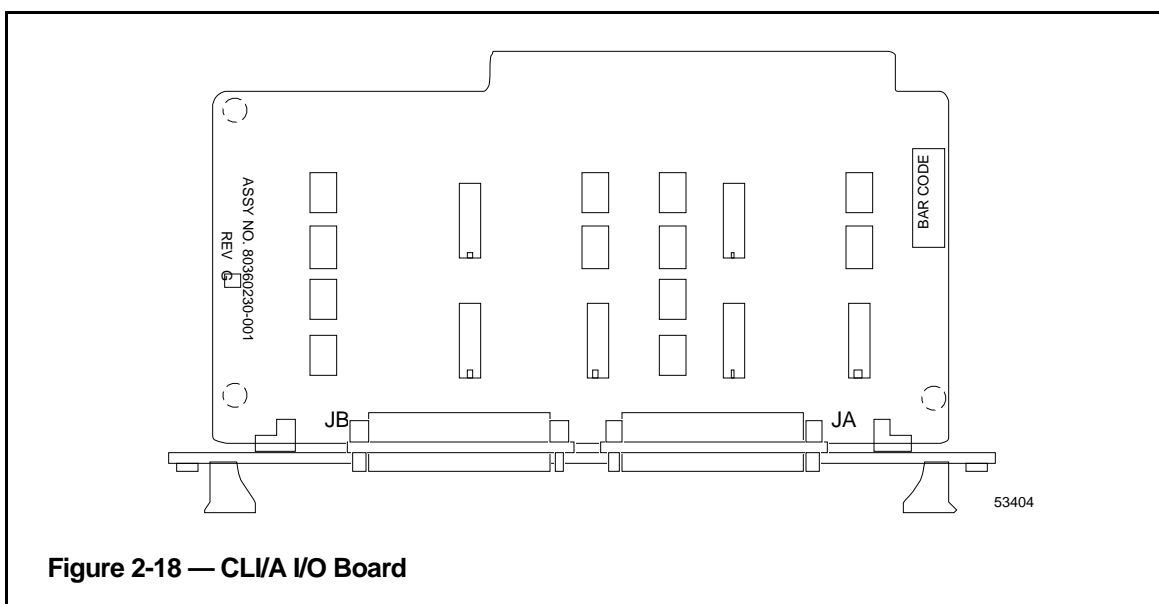
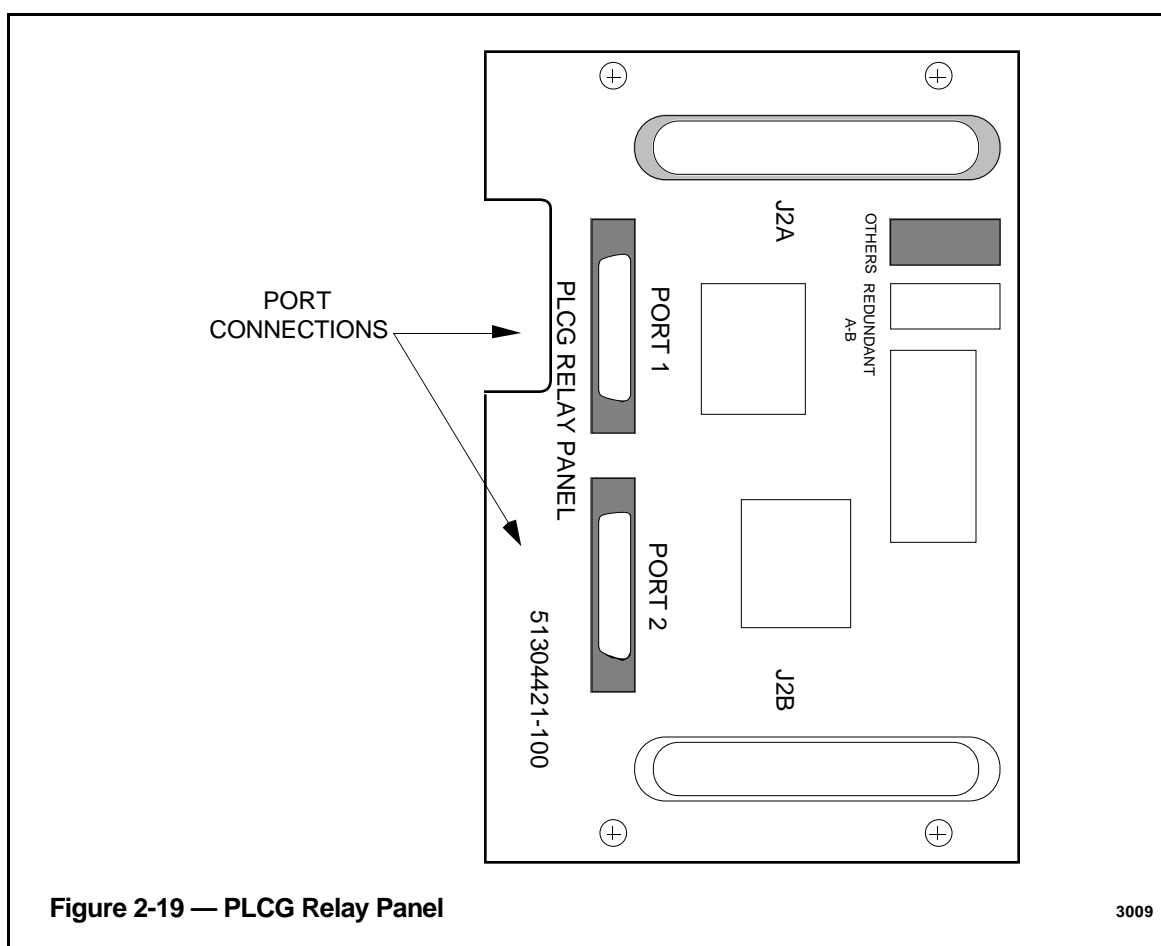

Figure 2-18 — CLI/A I/O Board

## 2.8.5 Optional EPLC Gateway

The optional Enhanced Programmable Logic Controller Gateway (EPLCG) allows connection to various Programmable Logic Controllers. You must configure your EPLCG and prepare the other end of the RS232 cable(s) according to the PLC (and modem) you are using. Refer to the *EPLC Gateway Planning, Installation & Service* manual in the *Implementation/EPLC Gateway* binder and the manuals with your PLC for more detailed information.

1. Remove the rear center-section cover of the tower and check that the pinning header is plugged into the **OTHERS** socket near the top right side of the PLCG relay panel (refer to Figure 2-19).
2. Connect the PLCG RS232 cable (51304514-100) to either **PORT 1** or **PORT 2** on the PLCG relay panel (see Figure 2-19). Use a small screwdriver to tighten the screws (2) on the connector.



3. An additional cable may be connected to **PORT 2** or **PORT 1** (see Figure 2-19) if your PLC configuration uses it. Use a small screwdriver to tighten the screws (2) on the connector.
4. Using a cable-tie (51190879-001) on each cable, fasten the cables to their strain-relief clamps (marked OPTIONS in Figure 2-5 or 2-7) on the lower transition panel.

## 2.9 OPTIONAL LCN UPGRADE

The LCN upgrade kit can connect a base Enhanced Micro TDC 3000 systems into a standard LCN system. There are 6 different LCN upgrade kits: one to accommodate either 5 or 7 empty chassis for nodes to be moved into. The installation process is fairly involved in that those nodes not associated with the Universal Station node will have to be moved from the Enhanced Micro TDC 3000 towers to individual 5-slot modules located in an LCN cabinet. The 5-slot modules in the cabinet come equipped with a power supply and fan mounted in the cabinet and coax cabling already assembled.

The History Module Drive must also be removed from the Enhanced Micro TDC 3000 and reassembled in the WDA Module located in the cabinet.

Up to two Universal Station (US) nodes may remain in the Enhanced Micro TDC 3000 to function with the coax interface, but must be relocated to appropriate slots. (Additional USs will each require an additional Enhanced Micro TDC 3000 tower with multinode module and power supply.) The remaining slots can no longer be used and blocking panels are included with the upgrade kits. LCN coax connections from the console to the LCN cabinet and the cabinet to the LCN system must then be performed. Different configurations are allowed for, but there are a number of constraints to keep in mind. These constraints are listed in the upgrade kit instructions.

Finally, you will need to reassign node numbers in the Enhanced Micro TDC 3000 to ones that are compatible with the LCN system. Node reassignment is described in *LCN Guidelines - Implementation, Troubleshooting, and Service* in the *LCN Installation* binder. Detailed directions for performing this upgrade can be found in the *MX-ZUKB50, 51, 52, or MX-ZUKB70, 71, 72 Upgrade Kit Installation Instructions*. The instructions you receive with the upgrade kit will depend on the number of nodes being upgraded.

## 2.10 INSTALLATION WRAP-UP

1. Check to see that all signal cables and coaxial cables entering towers are properly secured to the rear of the towers by strain-relief clamps or connector screws. Install the rear covers with star washers on both towers.
2. If you have not already done so, dress signal and power cables neatly, at the rear of the system, so that they will not be a personnel hazard. Dress cables that leave the area to connect to UCN taps, etc., so they will not be stepped-on or damaged in any way.
3. Gather packing material, boxes, and pallets and remove them from the operations room. Temporarily store the shipping boxes in the event something must be returned to the factory.
4. Clean and tidy the operations room to keep operating media (cartridge disks) from being unduly exposed to dust and foreign material.
5. Check each cartridge slot of the cartridge drives. If there are polystyrene shipping inserts in the slots, carefully remove them.
6. Make sure the power switches on both towers, the color monitor(s), and the printer are all **OFF**.
7. Plug power cords from all units into the proper receptacles for the power required.
8. Continue on to Section 3 for power-up tests and other checkout procedures.



## CHECKOUT Section 3

*This section tells you how to check the Enhanced Micro TDC 3000 Control System after it has been installed, plugged in and is ready to go.*

### 3.1 POWER-ON TESTS

Do not perform any of these tests until the Enhanced Micro TDC 3000 Control System has been installed according to Section 2. Check that the rear panels on the towers have been installed and all signal cables and power cords connected. See that the area is cleared of packing material and other installation debris, and the area is clean. Check that all power switches are off.

You will now perform a series of checks and tests to insure the equipment is working. If any of the tests are not met, refer to Section 6, Service.

#### 3.1.1 Tower #1 Electronics Checks

Tower #1 is the tower on the right with two black cartridge drives in the upper left corner.

1. Use both hands to remove the front panel from tower #1 by grasping the edges of the panel near the bottom and pulling the panel straight out. Spring-loaded catches on each side of the panel disengage, and the panel may be removed by pulling it out and down. Be careful not to damage the cartridge drives when removing the panels.

#### NOTE

The front panels of the towers may be removed or replaced while power is on because there are no lethal voltages exposed. Of course, observe caution with metallic objects because the equipment may still be damaged if low voltages are shorted.

2. You now have access to the front of the Multinode Module in tower #1. Locate the power switch (see Figure 3-1). Before turning power on, ensure the **LO-NOM-HI** jumper just below and to the right of the power switch is set in the **NOM** or center position. This is a maintenance jumper that is not to be changed by the user.
3. Compare your module with the Figure 3-1 illustration. Note the module contains four nodes and each node has a processor board in the first board slot and a personality or peripheral board in the second slot. Nodes have unique numbers from 1 to 8 (not A, B, C, D as in the figure) and are factory set. You will identify the node numbers in an upcoming test. Other board slots may or may-not contain boards, therefore, are shown shaded. Note a horizontal row of green LEDs along the bottom, with another row of either yellow or green LEDs just above them. Note each processor board contains a display containing several red LEDs and a red alphanumeric status display.

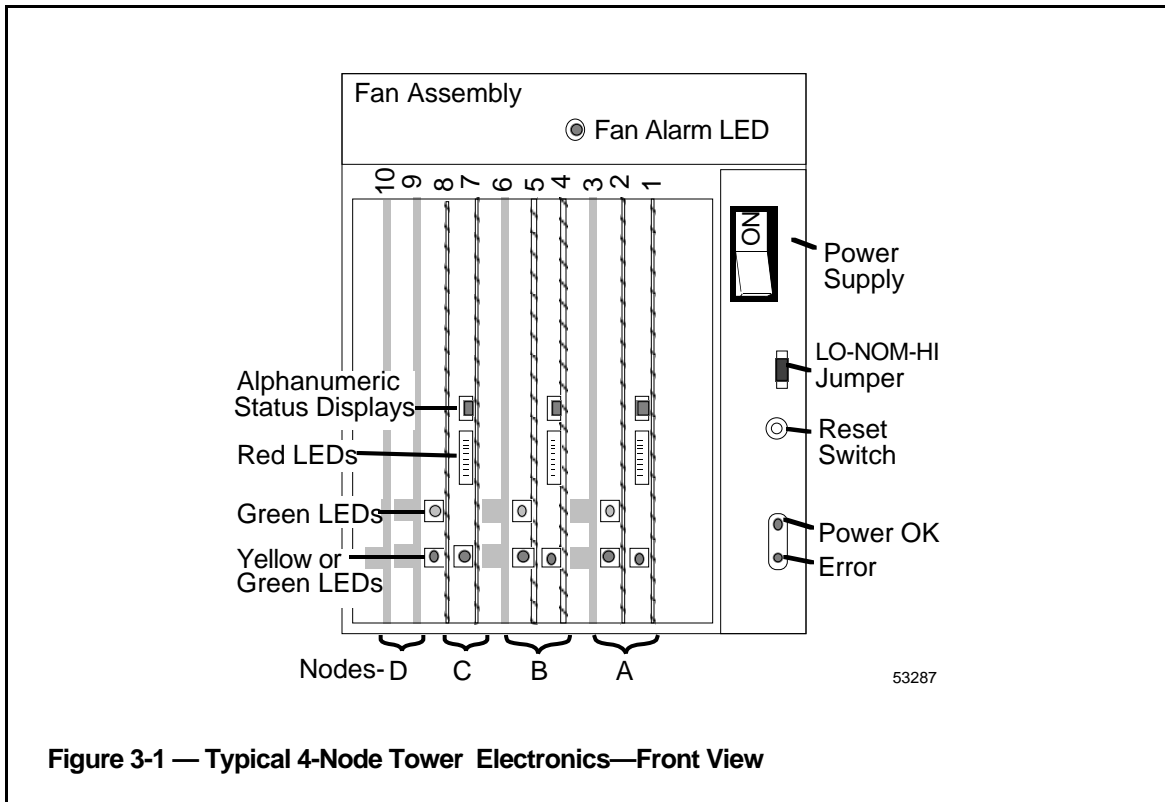

Figure 3-1 — Typical 4-Node Tower Electronics—Front View

4. Now initiate power-up tests on tower #1 by setting the **POWER** switch to **ON**. The red LEDs on the boards light for a few seconds (it takes less than 30 seconds to complete the power-up tests), then they turn off and the green LEDs turn on. If any red LEDs on the boards remain on, some portion of the power-up tests have failed—record the alphanumeric status display code and proceed to Service, Section 6 in this manual.

If the power-up test is successfully completed for all nodes, all green LEDs on all boards are on (there may also be some yellow LEDs on or flashing), and the alphanumeric status display indicates the node address (ranging from 1 through 8) for each of the nodes. Temporarily record these three node numbers.

5. Check the power supply status LEDs (**POWER OK** and **ERROR**) and the **FAN ALARM** LED. Note the **FAN ALARM** and **ERROR** LEDs are off and the **POWER OK** LED is on (it is a fault condition if both the **ERROR** and **POWER OK** LEDs are **ON**).
6. Press the momentary **RESET** switch. Note the power-up tests are initiated similar to step 4, and the results are satisfactory.
7. Replace the front cover on tower #1 by holding the cover with both hands and catching the top of the cover into the lip at the top of the cabinet. Be sure the sides of the cover are on the outside of the cabinet. Now swing the bottom of the cover into place, pressing firmly on the bottom until the cover is secured by both spring-loaded catches.

### 3.1.2 Tower #2 Electronics Checks

Tower #2 is similar to tower #1, but it has a 512 MB hard disk drive where the cartridge drives are located in tower #1 (but the hard disk drive is normally hidden by the front panel). Note the Multinode Module in tower #2 may not be as completely filled with nodes as it was in tower #1.

1. Now repeat all the tests in subsection 3.1.1 again on tower #2.

#### NOTE

Your system has already been shipped with bootload software (Directory & LDR) installed on the Winchester disk drive. The HM (History Module) automatically boots its node after power-up tests in this tower have finished.

It is OK to press the RESET switch or turn the power off in the middle of this automatic bootload because there is no write activity to the drive at this time. However, in an operating system, NEVER press the RESET switch if there is a possibility of a write-in-process. Please note the HM automatically boots every other time the RESET switch is pressed.

2. Note the node numbers used in tower #2 are different from the node numbers you found in tower #1. Temporarily record these node numbers. Now compare all of your node numbers with Table 6-1 in Section 6 of this manual and verify you have the correct node types.

### 3.1.3 Color Monitor Check

1. Set the color monitor power switch to ON. On the front of the 20" monitor, beneath the bezel, the pushbutton to your right is the Power ON/OFF switch. The left pushbutton is for degaussing. The power switch on the 21" monitor is located at the right front of the monitor, just below the display screen.
2. Adjust brightness for best resolution on the blinking character that appears on the upper left side of the screen. On the front of the monitor, beneath the bezel, the left thumbwheel is the Brightness control. The right thumbwheel is the Contrast control.
3. Position (tilt) the screen display for comfortable viewing.

### 3.1.4 Printer Checks

These tests are only initiated when power is first turned on, therefore, always start the tests with power **OFF**. The power switch is at the rear of the printer, just above the line cord.

Run both of these printer tests after initial installation. Also run the self-test any time a new ribbon or print head has been installed on the printer. Inspect the self-test printout carefully to insure high quality print copy from your printer.

Run the user diagnostic test whenever you suspect a malfunction in the printer electronics.

Table 3-1 shows the states of the printer display while in normal operation and when the tests are run. If these tests do not run satisfactorily or if the user diagnostic test does not finish, consult Service, Section 6, in this manual.



#### 3.1.4.1 Printer Self-Test

1. Ensure that there is ribbon and paper in the printer, and that the top cover is closed.
2. Press and hold the **ON LINE** button while setting the **POWER** switch to **ON**, then release the **ON LINE** button.
3. The printer display first shows **ASPI**, then the printer begins its self-test, printing a full line of characters, time-after-time, advancing one character at the beginning of each line until the full character set is printed. While printing the self-test, the printer display shows **TEST**. The test continues indefinitely.
4. Press the **ON LINE** button to stop printing. The printer shows **WAIT**. Press the **ON LINE** button again and the printer displays **LINE**. It is then on-line.

Table 3-1 — States of ASPI-41 Printer Display

<b>NORMAL OPERATION</b> Turn power on	
ASPI	Display when turned on.
LINE	On-line—ready to print.
<b>SELF-TEST</b> Hold <b>ON LINE</b> button while you turn power on	
ASPI	Display when turned on.
TEST	Continuous pattern printed.
	• (Press <b>ON LINE</b> button here)
WAIT	Off-line—waiting.
	• (Press <b>ON LINE</b> button here)
LINE	On-line—ready to print.
<b>USER DIAGNOSTIC TEST</b> Hold  button while you turn power on	
ASPI	Display when turned on.
BBBB	Start of test (“B” signifies a “box” is being displayed).
*BBB	Test cycles through four states.
**BB	
***B	
****	
T&D1	Sequences from test “1” through test “G.”
T&D-	
T&DG	
A 41	Display is flashing—Printer identifies itself.
T&DH	Test H.
LINE	Configuration is printed (see Figure 3-2).
T&DI	Test I.
?END	End of T&Ds—waits 5 seconds to see if you want to start again.
ASPI	No—T&Ds are off.
LINE	On-line—ready to print.

### 3.1.4.2 Printer User Diagnostic Test

1. Hold the  button while turning the printer **ON**. Several tests are run and their results displayed. The steps which follow tell what the various displays will look like. Since there are no pauses between tests, you may need to run this test more than once.
2. The display will show a sequence of 4 boxes, then 3, 2, and so on until none are displayed. Each box is replaced with an asterisk.
3. The letters **T&DX** are then displayed, where **X** is a sequence of numbers and letters as various Tests and Diagnostics (T&Ds) are performed. After **T&DG** is displayed, the printer flashes **A 41**, indicating it is an ASPI-41 printer. It then completes the T&D tests with **T&DH**, goes on **LINE**, and prints its User Test configuration which looks something like Figure 3-2.
4. The test finishes with test **T&DI**, then displays **?END** for about 5 seconds. The display then cycles to **ASPI**, then **LINE**, and is ready to print.
5. If you wish to continually run through the diagnostic tests, press  during the time **?END** is being displayed. Most likely, if one of the diagnostic tests fails, it will stop while displaying a **T&DX** figure. Record the number or letter represented by **X** before proceeding to service it.

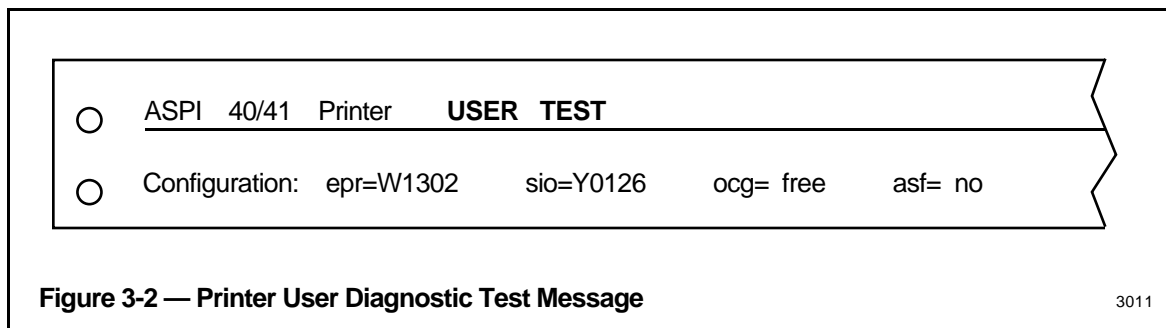

### 3.1.5 Cartridge Drive Checks

1. First, select a cartridge and check that the protect switch is in the **WRITE PROTECT** position (see Figure 1-4) on the cartridge.
2. Drive power is supplied by the tower #1 power supply. If power is off, the latch pin in the drive prevents cartridge insertion. Carefully insert the cartridge in the drive loading slot (see Figure 1-4). Note the green LED on the drive blinks for 5 to 10 seconds while the disk comes up to speed, then goes on steady as the yellow LED flashes (only once at this time) to indicate drive access. The green LED remains on steadily as long as the cartridge is in service. The yellow LED will flash periodically when software writes or reads the disk in the future, but the period of the flash will be very brief.

#### CAUTION

DON'T attempt to remove the cartridge from the drive while the green LED is ON or BLINKING. Also, DON'T attempt to move the protect switch on the cartridge while the cartridge is installed in the drive.

Serious damage may result to the cartridge or the drive if these cautions are not heeded.

3. When you wish to remove the cartridge, press the stop button on the drive and note the green LED blinks for several seconds, then goes off. Only then may you safely remove the cartridge.

### 3.2 SYSTEM CHECKOUT WRAP-UP

If your equipment passes the checks and tests in this section, proceed to the Implementation and Operational Guidelines, Sections 4 and 5. If not, correct the problem by referring to Service, Section 6 of this manual or consult your Honeywell representative.





## IMPLEMENTATION

### Section 4

*This section guides you through the configuration and data-entry process for the Enhanced Micro TDC 3000 system. If you are familiar with the Engineering Personality functions, you may be able to implement your system with little or no reference to the standard LCN bookset, but in case you need them; references are provided to the binders and publications that contain the detailed implementation references and instructions.*

#### 4.1 IMPLEMENTATION OVERVIEW

The Enhanced Micro TDC 3000 systems consist of a limited set of equipment and functions, so the range of implementation tasks is reduced to those supported by the purchased equipment and options. Therefore, in this implementation section, we describe a predetermined set of implementation choices and values, some of which are fixed by the characteristics of the Enhanced Micro TDC 3000 system (for example, node numbers and node-pair numbers), but most of which you can change to suit your application.

##### 4.1.1 Database Configuration

The following example Enhanced Micro TDC 3000 system databases are described in this section:

- Network Configuration—Network Configuration File (NCF)
- UCN/APM Box Points and Data Points—Parameter values for UCN and APM Box Point parameter values, which must be built and loaded before data points can be built.
- Area Database Configuration—Area database

##### 4.1.2 The Implementation Process

“Implementation” includes the individual startup of the system, as described under 4.2, and the configuration and entry of the remaining data that defines data points, pictures (schematics), buttons, Free Format Logs, and user-written programs. You can load all or part of the prebuilt files or configure the entire system yourself.

For a quick overview of the implementation process, refer to *Implementation Overview* in the *Implementation/Startup & Reconfiguration - 1* binder. For additional definition and guidance, see *Configuration Data Collection Guide* in the *Implementation/Startup & Reconfiguration - 2* binder.

Detailed configuration and data entry instructions applicable to the Enhanced Micro TDC 3000 system are in the following binders:

- Implementation/Startup & Reconfiguration - 1/2/3
- Implementation/Engineering Operations - 1/2/3
- Implementation/Application Module - 1/2/3
- Implementation/Advanced Process Manager - 1/2

## 4.2 SYSTEM STARTUP

If you have the standard system: an AM, one or two NIMs, one or two Universal Stations, and a standard double-sided APM cabinet, you may want to skip any configuration changes, load the standard prebuilt files, and go right into the Universal Personality. If so, skip this section and go to subsection 5.1.1.1, How To “Bootload” US 1 with the Universal Personality from a Pre-Loaded HM.

Follow the procedures in this section—

- if the system has an optional CG or EPLCG
- if you want to make configuration changes
- if boards were added to the standard APM cabinet (see Chart 4-1)
- if the system has a nonstandard APM cabinet (see Chart 4-1)
- if you just want to learn about the configuration process,

Prebuilt files are supplied for the Local Control Network (LCN) including the AM and NIM, one Area, and a few AM/APM points. Two Universal Stations and two NIMs are included in the standard configuration but if only one of these pairs is actually present, the other will show a status of OFF. Parameters in the prebuilt Local Control Network configuration files (NCF) are shown in subsection 4.2.2. Parameters in the prebuilt data points and configurable buttons are shown in appendices to this publication. Parameters in the prebuilt Area Database are shown in subsection 4.8.2.

To make configuration changes, the Enhanced Micro TDC 3000 must have an Engineering Keyboard connected to the station with the cartridge disk drives.

**Selecting**—In the pages that follow, when instructed to **select** something on the display, do so by moving the cursor onto the target and then press the SELECT key on the appropriate keyboard. If you have the optional touchscreen, touch the target to move the cursor onto the target; the select is performed by removing your finger from the display. If you have the optional trackball, position the cursor onto the target with the trackball and press the select key on the trackball. When instructed to **enter** something, move the cursor to the appropriate port, key in (type) the data, and then press the ENTER key on the appropriate keyboard or on the trackball. In Section 4, use the Engineering Keyboard unless otherwise instructed. On the trackball, the right-hand key is Select and the left-hand key is the Enter key.

## 4.2.1 Local Control Network Configuration

You can load the prebuilt file or configure the entire network yourself. The following questions will help you pick the next step.

### NCF Configuration Questions—

1. Does this system have a Computer Gateway (CG) or Enhanced Programmable Logic Controller Gateway (EPLCG)?
  - Yes - go to step 2
  - No - go to step 4
  
2. Do you want to load the prebuilt LCN Network Configuration file and add the EPLCG or CG node later with a procedure called On Line Network Configuration? You should have some experience with the LCN file system to do this?
  - Yes - go to step 5 Watch for EPLCG/CG notes in the procedures.
  - No - go to step 3
  
3. Follow instructions in the *System Startup Guide—Cartridge Drive*, in the *Implementation Startup & Reconfiguration - 1* binder to configure the system. Instructions for a first-time start up of any LCN-based TDC 3000<sup>X</sup> system, including the Enhanced Micro TDC 3000 system, are provided to take you step-by-step through a first-time startup of a system that has no database. The procedures include the building, loading, and installing all data needed to attain a minimum operating system on which you can build the remainder of your system- and process-related data.

### NOTE

When the System Startup Guide is used to configure a system:

Performing certain procedures will overwrite standard software that was shipped on the History Module (CG and EPLCG software is not on the HM anyway; this software is on the cartridges).

A EPLCG is configured as a subset of the Hiway Gateway, therefore, follow the instructions for an HG configuration except where noted and refer to the HG Forms and HG manuals. You must configure an HG node in Task 9 and load &HGO and &HGG software in Task 16.

4. Do you want to load the prebuilt LCN network configuration file? If you are not familiar with the configuration process, this is the fastest way to get a station running the Engineering Personality. You can reconfigure the system later.
  - Yes - go to step 5.
  - No - go to step 2 in 4.2.1.1.
  
5. Follow the instructions in subsection 4.2.1.1 to load the prebuilt network configuration file (NCF).

#### 4.2.1.1 Loading Prebuilt Network Configuration Data

In the steps that follow, you will load US 1 with the Universal Personality and the prebuilt NCF file. The Universal Personality allows you to switch quickly between the Operator's Personality and the Engineering Personality. The Engineering Personality is used to configure the system or to change system configuration.

1. If not already off, turn off the power switch on tower 1 (the right tower) and on tower 2 (the left tower) for a few seconds and then back on. Loss/return of power in tower 2 resets the node(s) and forces the HM to autoboot. Loss/return of power in tower 1 resets the nodes in that tower. Wait for > to appear in the upper left corner of the screen of the monitor connected to tower 1.
2. On the Operator's Keyboard, press LOAD. N , 1 , 2 , 3 , 4 , X appears.
3. On the Operator's Keyboard, press the ALPHA SHIFT key (until the indicator comes on), key in N, then press ENTER. Several messages appear, ending with OPR, UNP?
4. On the Operator's Keyboard, key in **UNP** and press ENTER.
5. Wait a few minutes for the System Status display to appear. Press CTRL/HELP on the Engineering Keyboard to go to the Engineering Main Menu.
6. The Engineering Main Menu should be on the screen. On the Engineering Keyboard, press PF1. Enter the schematic name **KEYLOCK** and press ENTER. Select the ENGR target. For more information on how to use the access keylock, refer to subsection 5.3.3, Keyswitch Access Levels .

#### Set the Time and Date—

7. Select the SYSTEM STATUS display target on the Engineering Menu. On the System Status display, select the TIME/DATE target.
8. When the TIME/DATE CHG targets appear, select the DATE CHG target. Key in the current day, month, and year (for example, 15 MAR 92) and press ENTER. The current date should appear in the upper right corner of the display.
9. Select the TIME CHG target and then key in the time in hours and minutes (for example, 14 25). Press ENTER and the current time should appear in the upper right corner of the display.

**Check HM Operation—**

10. On the Operator's Keyboard press the SYSTEM STATUS key. On the System Status display, select the HM Node Object Box, then select the NODE STATUS target.. If the HM status is anything other than OK, you should not continue until the problem is fixed. For information on how to use the "Load\_HM.EC" file on &C8, refer to Sections 13 through 17 in the *System Startup Guide - Cartridge Drive*, in the *Implementation/Startup & Reconfiguration - 1* binder.

If the status is OK, and you want to check the contents of the HM, do the following—

On the Engineering Main Menu, select COMMAND PROCESSOR.

Key in the command LSV NET. Press ENTER. The resulting output on the screen should appear similar to Table 4-1. Table 4-1 shows all volumes and directories on the HM. You may not have them all. For example, &CGO and &HGO are optional Computer Gateway and Hiway Gateway programs.

**4.2.1.2 Network Configuration Completion**

At this point the Local Control Network is configured with the prebuilt NCF file. You can browse through the items on the left column of the Engineering Menu if you like by selecting the targets one at a time. Some of the configuration displays have several pages. Use the PAGE FWD and PAGE BACK keys to see all pages. Return to the Engineering Menu by pressing CTL/HELP after looking over each item. Refer to the subsection 4.2.2 for a listing of the prebuilt NCF file.

**Optional EPLCG or CG—**

If the system has an optional EPLCG or CG node, you can add either or both to the network with the On-Line Reconfiguration procedures described in Section 7 of the *Network Data Entry* manual. When a EPLCG or CG node is added to the network, it must be loaded with its Operator Personality. You will want to have these personalities on the HM, however, they are not preloaded like the others and all HM space is allocated. Solution: the existing HM volume named PICS is large enough to hold this software. Create directories for the files you need to load (e.g., &HG0, &HGG, and/or &CI0). Refer to Section 16 in the *System Startup Guide—Cartridges*, for loading procedures and Section 18 to load the Operating personality into the node(s). Note that a EPLCG is configured as a subset of the Hiway Gateway node.

The next step is to load the Gateways and Modules (subsection 4.3).



## 4.2.2 Prebuilt Network Configuration Data

The following data shows entries in the prebuilt NCF file. This data is shipped as file NCF.CF on volume &ASY in the History Module and on cartridge &C8.

**Units, Unit Names** 10 Units,UNIT 1 through UNIT 10

**Area Name - Area Description** AREA01 - AREA01  
AREA02 - SPARE

**Console Number, Console Description** 1, MICRO TDC 3000  
**LCN Nodes** US: 1  
US: 2  
NIM: 3 (Primary)  
NIM: 4 (Secondary)  
AM: 5  
HM: 6  
CG: 7  
US: 8

### Universal Stations

Node 1  
Consloe # 1  
Station # 1  
Default Area AREA01  
Cartridge Drives 1 & 2  
Printer Number 1  
Default Access Level OPER  
Oper Kbd YES  
Touch Screen YES  
Engr Kbd YES

Node 2  
Consloe # 1  
Station # 2  
Default Area AREA01  
Cartridge Drives NONE  
Printer Number NONE  
Default Access Level OPER  
Oper Kbd YES  
Touch Screen YES  
Engr Kbd YES

Node 8  
Consloe # 1  
Station # 4  
Default Area AREA01  
Cartridge Drives NONE  
Printer Number NONE  
Default Access Level OPER  
Oper Kbd YES  
Touch Screen YES  
Engr Kbd YES

<b>Application Module</b>	
Node	5
Startup Mode	HOT
Assigned Units	02, 04, 06, 08
<b>History Module</b>	
Node	6
Node Pair No.	1
<b>Network Interface Modules</b>	
Nodes	3 & 4
Process Network (UCN) No.	1
<b>Computer Gateway</b>	
Node	7
Startup Mode	Hot
Assigned Units	01, 03, 05, 07, 09
<b>System Wide Values</b>	
<b>System ID</b>	
System Descriptor	MICRO TDC 3000
System ID	TDC
<b>Clock Source</b>	Clocks located in nodes 5&6
<b>User Average Period</b>	10 minutes
<b>Shift Data</b>	
Shifts per week	21
Monthly period type	CALENDAR
Report starts hour + day of week	0 MON
Shift starts	1 MON
Each shift length	8 hours
<b>Console Data</b>	
NCF Source	NCF>&ASY>NCF.WF
Fast/raise/lower rate	5 PERCENT PER INCREMENT
Printer page length	66
Printer page width	132
Trend pen delay	1 SEC
CL message Confirmation after acknowledgement	NO
Printed trend format	GRAPHIC
Real Time Journal size	100
Real Time Journal Header/Trailer messages	BEG/END
Contact Cutout Alarms on Alarm Summary	CLEAR WHEN ACKNOWLEDGED



**Horn Annunciator Policy**

Console Status Event	CONTACT_1
System Status Event	CONTACT_1
Operator Ack Only Message	CONTACT_1
Operator Confirm Message	CONTACT_2
Low Priority Alarm	CONTACT_1
High Priority Alarm	CONTACT_2
Emergency Priority Alarm	CONTACT_3
Contact 1 Output State	STEADY
Contact 2 Output State	STEADY
Contact 3 Output State	STEADY

**Alarm Management Configuration**

Red Color Alarm Priority	EMERGENCY
Priority Indicators On Alarm Displays	CHARACTERS
Three Color Alarm Priority	
Emergency	RED
High	YELLOW
Low	MAGENTA
Low Priority Alarms in Alarm	NO
Summary	
Initial Alarm Summary Sort State	PRIORITY
Audible Alarm Annunciator	0
Suppression Rime-out (seconds)	
Alarm Summary Freeze Time-Out (Sec)	0
Area-Based Process Alarm Ack?	NO

**Alarm Command Access Table**

Change Alarm Summary Sort State	OPER
Chg Alarm Priority Filter on Alarm	OPER
Summaries	
Chg Audible Alarm Annunciation	OPER
Suppression	
Alarm Summary Display Freeze	OPER

**Physical Node Command Access Table**

Load Operations Non US Node	OPER
Load Operation Local Console US	OPER
Load Operation Remote Console US	SUPER
Dump Node	OPER
Override Dump	OPER
Shutdown Node	SUPER
Override Shutdown	ENGR
Enable/Disable Load/Dump	SUPER
Change Time or Date	OPER
Change Area	SUPER
Override Change Area	SUPER
Change ALENBST	ENGR
Idle Process Manager	OPER
Demand Checkpoint Node	OPER
Enable/Disable Auto Checkpoint	SUPER
Switch Primary to Secondary	OPER
Override Switch Primary to Secondary	SUPER
Enable/Disable History Collection	OPER
Hot/Warm/Cold/On-Process Start AM	OPER
Warm/Cold Start HG	ENGR
Printer Assignment Change	OPER
Clear Maintenance	SUPER
Load Test	SUPER
Load Init	ENGR
No Point Access Load	ENGR
Command Load of Process Gateway Node	OPER
Command Restore of Process Network Devices	OPER
Commaand Load of Process Network Devices	OPER
Command Checkpt of Proccess Network Devices	OPER

**Miscellaneous Commands Access**

Sequence Command Load Program	OPER
Sequence Command Save Program	ENGR
Box Variable Change Access	ENGR
System Event Acknowledge Access	OPER
Floppy Init Access	SUPER
Access Lvl to Change View Access	SUPER
Access Lvl to Chng Unit Assignment	OPER
Access Lvl to Chng Unit Deassign	SUPER
Access Lvl to Chng Unit Alarm Enable	OPER
Access Lvl to Chng Unit Alarm Disable	SUPER
Access Lvl to Chng Unit Alarm Inhibit	SUPER
Process Network Fast Commands	OPER

**Software Option Key File**

HG POINT DISPLAY RANGES  
 ENHANCED TREND PENS  
 HM DISK REDUNDANCY  
 PRINTED SUMMARIES

## Volume Configuration

<b>Node Pair Number</b>	1
Number of Winchester Disks	1
Disk Type/Size	6
HM Init Personality?	YES
System Volume?	YES
GDF Files Included?	YES
File Manager Descriptors?	NO
Area SOE Journal Size	3750
Burst Buffer Size (For Process/System Journals)	4000
System Unit Journals?	YES
Status Change	4096
Error	4096
Maint	2048

### Select Volumes for This HM

PROGRAM IMAGE  
 AREA  
 CHECKPOINT  
 CONTINUOUS HISTORY  
 JOURNALS  
 CL STORAGE  
 USER FILE STORAGE

### Program Image Volume Configuration

Personalities Selected	CM II,HG II,AM II,USOPR II, USUNPII,NIM II,NG II CM IV,HG IV,AM IV,USOPR IV, USUNP IV,NIM IV,NG IV
Dump Volume Size (KB)	18000

### Area Data Volume Configuration

Area Name	AREA 01
Volume Size (KB)	5000
Number Files	500

### Physical Node for Checkpoint Configuration

Node 3 (NIM)	20000 kb, 100 files
Node 4 (NIM)	0 kb, 0 files
Node 5 (AM)	10000 kb, 100 files
Node 7 (CG)	10000 kb, 100 files

### Continuous History Groups Configuration

Unit IDs	1 - 10
Groups per Unit	10

**Continuous History Group Options**

Unit IDs	1 - 10
Groups per Unit	10
Save Options	SNAPSHOTS & USER AVG
Snapshot Hours	168
User Avg Hours	336
Archive	NO

**Process Unit Journal Configuration**

Unit IDs	1 - 10
Process Alarms	6000
Process Changes	6000
Operator Messages	1000

**CL Storage Volume Configuration**

Hiway Network (UCN)	1
Number of Files	99
Volume Size (kb)	20000

**User File Storage Configuration**

Volume ID - PICS	5000 Files, 200000 kb
Volume ID - CL	5000 Files, 150000 kb
Volume ID - TEST	5000 Files, 150000 kb

## 4.3 LOAD GATEWAYS AND MODULES

The following steps load the modules (nodes) with their operating personalities. The HM also contains prebuilt data for the Enhanced Micro TDC 3000 configuration. You are given the option to select blank (null) files as each module is loaded. Subsection 4.3.1 shows the preconfigured NIM data.

### 4.3.1 Loading the AM

1. On the Operator's Keyboard, press the SYSTEM STATUS key. On the System Status display, select the AM Node Object Box, then select the NODE STATUS target.
2. On the Application Modules Node Status display, select the AM node number (05).
3. When the Node Load targets appear, select the MANUAL LOAD target .
4. Select a load option (e.g., COLD LOAD).
5. When the Program Source target appears, select DEFAULT SOURCE. Then select the EXECUTE COMMAND target.
6. When the Data Source target appears, select DEFAULT SOURCE, and then select the EXECUTE COMMAND target. Press the ENTER key to start loading. In a few minutes the AM status should change from LOAD to OK. Note that because the AM checkpoint is on the HM, one prebuilt AM point is loaded. If you do not want to load that point, you may choose ALTERNATE SOURCE for the Data Source and read the null checkpoint from cartridge &C8. The prebuilt points are described in Appendix A of this manual.

### 4.3.2 Loading the NIM

1. On the Operator's Keyboard, press the SYSTEM STATUS key. On the System Status display, select the NIM Node Object Box, then select the NODE STATUS target.
2. On the Process Networks Node Status display, select the primary NIM node number (03).
3. Select the LOAD/DUMP target.
4. When the Node Load targets appear, select MANUAL LOAD target.
5. When the Load Option targets appear, select OPERATOR PROGRAM.
6. When the Program Source target appears, select DEFAULT SOURCE. Then select the EXECUTE COMMAND target. The Data Source display appears.
7. On the Data Source display, select DEFAULT SOURCE; then select the EXECUTE COMMAND target. Press ENTER to start loading. In a few minutes the NIM status should change from LOAD to OK.

If you do not want to load the preconfigured data, you must use a null checkpoint as the data source. The null checkpoint is on cartridge &C8. Insert cartridge &C8. When prompted for the Data Source, choose ALTERNATE SOURCE and then select the drive number that contains &C8. Use the procedures in Section 32 of the *System Startup Guide—Cartridges* to configure the NIM.

8. If the System has an optional redundant NIM, it is loaded in a similar way except choose node 04.

#### 4.3.2.1 NIM Prebuilt Configuration Data

These entities define the primary NIM as node 01 and the redundant NIM as node 02 on process network 01 (the UCN). \$NM01N01 specifies that NIM 1 when operating as the primary NIM, has responsibility for control, parameter fetching and storing, alarming, and checkpointing and that data is to be loaded in both the NIM and the APM. A similar entity is built for the optional, secondary NIM if it is present. This data is in the checkpoint for the NIM and was loaded when you specified the Default Data Source.

Parameter (Name)	Description	Value, Primary NIM	Value, Sec. NIM
NTWKNUM	Network number	01	01
NODENUM	Node number	01	02
NODETYP	UCN Node type	NIM	NIM
NODASSN	Node assignment	ThisNIM	ThisNIM
LOADSCOP	Load scope	NIMandPM	

## 4.4 LOAD THE ADVANCED PROCESS MANAGER

The instructions that follow assume that the NIM was loaded in a preceding section and has a status of OK. Power must be on at the APM cabinet. If you are not using a standard APM cabinet as described in Chart 4-1, refer to Task 32 in the *System Startup Guide*, for the procedures to build new IDFs and load the APM. If there were minor changes or additions to the standard dual access APM cabinet, you may wish to reconstitute the appropriate entities, change them and load them. Refer to the *Data Entity Builder Manual*, for the procedures.

### 4.4.1 Standard Double-Sided Nonredundant APM Cabinet

1. If the Engineering Main Menu is on the screen, select the SYSTEM STATUS target on the Engineering Main Menu. If not, press the SYSTEM STATUS key on the Operator's keyboard.
2. On the System Status display, select network 1 (the box with UCN01 in it).
3. Select the NTWK/HWY STATUS target.
4. On the UCN Status display, select the target 03 APM. The selected target should fill with color. The status must be ALIVE.
5. Select LOAD/SAVE RESTORE. The box should change to white.
6. Select PROGRAM LOAD, then select ENTER.
7. On the Program Source display, select DEFAULT SOURCE, then select EXECUTE. The Data Source display appears.
8. On the Data Source display, select DEFAULT SOURCE, then select EXECUTE. Loading should begin. In a few minutes, The APM status should change to IDLE.

9. On the UCN Status display, the target 03 APM should still be selected (filled with color).
10. Select LOAD/SAVE RESTORE. The box should change to white.
11. Select RESTORE DATA; then select ENTER.
12. On the Restore UCN Node display, select DEFAULT SOURCE, then select EXECUTE. When RESTORED is displayed, proceed to Step 12.
13. Select DETAIL STATUS. Check the boxes on the Detail Status display. For each implemented IOP, a box should contain the IOP type (e.g., HLAI) and the word IDLE.

#### 4.4.2 Expanded Standard APM Cabinet

If you are configuring a double-sided nonredundant cabinet with added IOP cards, use the procedure in 4.4.1, then reconstitute the entity \$NM01B03 (refer to the *Data Entity Builder Manual* for the reconstitute procedure). Add the extra I/O Modules to the configuration for the cabinet. Load the data by pressing F12.

To configure any other APM cabinet, follow the procedures in Task 32 of the *System Startup Guide—Cartridge Drive*.

#### 4.4.3 UCN/APM Box Point Configuration Data

The following entity defines the primary Advanced Process Manager Module as node 03 on process network 01 (the UCN). This checkpoint information was loaded as the Data Source for the APM. A redundant APM is configured as node 04 but otherwise contains default values.

Parameter (Name)	Description	Value, Primary APM
NTWKNUM	Entity name	\$NM01N03
NODENUM	Network number	01
NODETYP	Node number	03
NODASSN	Node type	APM
MOVPVTEXT	Node assignment	ThisNIM
BADPVTEXT	Moving text descriptor	Neither
	Bad PV text	Both

The following entity defines the physical configuration of the Advanced Process Manager and several key operational characteristics.

Parameter (Name)	Description	Value	Parameter	Description	Value
NTWKNUM	Entity name	\$NM01B03	NPMSLOT	No. of Process Module Slots	30
NODENUM	Network number	01	NUMERIC	No. Numerics in PM Box Pnt.	2047
NODETYP	Node number	03	SCANRATE	Scan rate	Reg1Log1
CTLOPT	Control option	On	PKGOPT	PMM Packaging Option	Nonredun
NCTLSLOT	Number of control slots	40	IOMFILEA	IOP file number	(see chart)
NPVSLOT	Number of PV slots	20	IOMCARDA	IOP card number	(see chart)
NLOGSLOT	Nmbr. of Logic slots	25	IOMTYPE	IOP card type	(see chart)
NDCSLOT	Nmbr. of Digital Comp. slots	150	FAILOPT(n)	Output failure option	Unpower

Chart 4-1 — APM Box Point I/O Chart (n = 1 through 40)

Double-Sided Cabinet, Nonredundant APM			
IOP Number	IOMFILEA File No.	IOMCARDA Card No.	IOMTYPE(n) Card Type
1	1	6	HLAI
2	1	7	AO
3	1	8	DI
4	1	9	DO
5	1	10	None
6	1	11	None
7	1	12	None
8	1	13	None
9	1	14	None
10	1	15	None
11	2	1	None
12	2	2	None
13	2	3	None
14	2	4	None
15	2	5	None
16	2	6	None
17	2	7	None
18	2	8	None
19	2	9	None
20	2	10	None
21	2	11	None
22	2	12	None
23	2	13	None
24	2	14	None
25	2	15	None
26	3	1	None
27	3	2	None
28	3	3	None
29	3	4	None
30	3	5	None
31	3	6	None
32	3	7	None
33	3	8	None
34	3	9	None
35	3	10	None
36	3	11	None
37	3	12	None
38	3	13	None
39	3	14	None
40	3	15	None

(continued)



Chart 4-1 — APM Box Point I/O Chart (n = 1 through 40) (continued)

Double-Sided Cabinet, Redundant APM			
IOP Number	IOMFILEA File No.	IOMCARDA Card No.	IOMTYPE(n) Card Type
1	1	6	HLAI
2	1	7	AO
3	1	8	DI
4	1	9	DO
5	1	10	None
6	2	1	None
7	2	2	None
8	2	3	None
9	2	4	None
10	2	5	None
11	2	6	None
12	2	7	None
13	2	8	None
14	2	9	None
15	2	10	None
16	2	11	None
17	2	12	None
18	2	13	None
19	2	14	None
20	2	15	None
21	3	1	None
22	3	2	None
23	3	3	None
24	3	4	None
25	3	5	None
26	3	6	None
27	3	7	None
28	3	8	None
29	3	9	None
30	3	10	None
31	3	11	None
32	3	12	None
33	3	13	None
34	3	14	None
35	3	15	None
36	4	1	None
37	4	2	None
38	4	3	None
39	4	4	None
40	4	5	None

## 4.5 LOADING THE EPLCG OR CG

If optional EPLCG or CG nodes have been added to the network configuration, they must be loaded with their own Operator Personalities as was done for the AM and NIM above. Use the Null Checkpoint on &C8 for the Data Source. Refer to Section 18 in the *System Startup Guide*.

## 4.6 DATA POINT BUILDING

After the various box points have been built and loaded, you usually proceed to build data points. One AM point and fifteen prebuilt APM data points of several different types are provided by Honeywell. Each such point is provided in an IDF and in an exception-build file. IOP types and slot location for these points are configured to match the standard cabinet in Chart 4-1 so if you do not have those card types and card locations numbers, you should either build your own points or revise the prebuilt points as desired.

The prebuilt AM point and APM points were automatically loaded if you chose the Default Data Source when loading the AM module and the APM cabinet. You can delete or change existing points or add additional points. If you chose to use the null checkpoints on cartridge &C8, no points were loaded. The prebuilt AM and APM points with all their parameters are listed in Appendix A to this manual. If you loaded the standard points and do not wish to make any changes or additions, skip to the next section.

You can use these prebuilt points as the basis for building other points or you can define your data points on the appropriate paper forms, (*PM88-501A* through *PM88-540* in the *Implementation/Advanced Process Manager - 1* binder), and then enter the data into the screen forms on a Universal Station. If you are somewhat familiar with the parameters, you can bypass the paper forms and go directly to the screen forms.

Data points are built and initially loaded with the Data Entity Builder (DEB). Detailed instructions for use of the DEB are in the *Data Entity Builder Manual*, in the *Implementation/Engineering Operations - 1* binder. Task 21 in the *System Startup Guide* shows examples of point building. Detailed descriptions of the parameters for each type data point are in the appropriate Parameter Reference Dictionary in the implementation binders.

**CG or EPLCG**—If you are implementing a CG or EPLCG, you should use the *System Startup Guide* for point building and all subsequent configuration of those modules.

## 4.7 CUSTOM FUNCTIONS

Once you have the system started, have completed network configuration, and have at least a few data points, you have the basis to complete the implementation process. This includes the following activities:

- Build pictures.
- Build Free Format Logs
- Configure buttons.
- Prepare user-written programs.

These activities are interdependent and do not have to be accomplished in any particular order. For example, in picture building, data points referred to by a process schematic must be built and loaded before the schematic can operate. Buttons on the Operator Keyboard are often configured to call up user-built schematics, so those schematics must exist before the button can function.

If you do not want to build or change any of the custom functions, you can skip to subsection 4.7.2 on Area Database Configuration.

### 4.7.1 Build Pictures

The Picture Editor is used to build process schematics, help displays, and other custom pictures used in day-to-day operation and for special purposes. Two prebuilt pictures are included in the user volume PICS. They are discussed later. If you do not want to build any additional pictures, skip to the next section.

To activate the Picture Editor, call up the Engineering Main Menu and select PICTURE EDITOR. Compile any new pictures that you build or existing pictures that you change.

Detailed picture-building information is in the following publications in the *Implementation/Engineering Operations - 2* binder:

- *Picture Editor Form Instructions*
- *Picture Editor Data Entry*
- *Picture Editor Reference Manual*

A step by step example of a simple picture editor building session is provided in Task 23 of the *System Startup Guide*.

## 4.7.2 Build Free Format Logs

Free Format Logs are printed logs whose form and content are user defined. If you do not want to build any Free Format Logs at this time, skip to the next section.

To activate Free Format Log building, call up the Engineering Main Menu; then select FREE FORMAT LOGS.

Detailed Free Format Log building information is in the following publications in the *Implementation/Engineering Operations - 1* binder:

- *Free Format Log Form Instructions*
- *Free Format Log Data Entry*

Section 26 in the *System Startup Guide* provides a step by step example of how to configure a Free Format Log.

## 4.7.3 Configure Buttons

Several user-configurable buttons are provided on the Operator's Keyboard and the Engineer's Keyboard (PF keys). These buttons can be configured to call up standard displays, custom displays (schematics), and to accomplish actions specified by most of the TDC 3000<sup>X</sup> actors. Note that the configured button actions execute when the Operating Personality is running. A fairly extensive prebuilt button configuration file has been shipped with the system. It is file BUTTON01 on the &D01 volume. Appendix B to this manual describes the preconfigured buttons. If you do not want to make any changes or additions, skip to the next section.

To activate Button Configuration, on the Engineering Main Menu, select BUTTON CONFIGURATION. To make changes or additions, read in the existing file. The command is Read NET>&D01>Button01 (or you can build a new file). After changes or additions compile the button file.

Detailed button configuration information is in the following publications in the *Implementation/Engineering Operations* binders:

- *Button Configuration Form Instructions (binder 1)*
- *Button Configuration Data Entry (binder 1)*
- *Actors Manual (binder 2)*

Section 24 in the *System Startup Guide* provides a step-by-step example of how to configure a few buttons.

## 4.7.4 Prepare User-Written Programs

You can use Honeywell's Control Language (CL) to write programs that accomplish user-defined functions and algorithms. CL programs in the Application Module (CL/AM programs) are bound to data points and execute as those points are processed in the AM. CL is used to write sequence programs (CL/APM programs) that execute in Advanced Process Managers.

If you do not want to write any CL programs at this time, skip to the next section.

### 4.7.4.1 CL Program Preparation

CL program preparation consists of

- Using the Text Editor to create and prepare a CL source file.
- Using the Command Processor to activate the CL compiler, which converts the source file to a listing file and an executable object file.
- For CL/AM, using the Command Processor to activate the CL linker, which links and loads the object file into the AM.
- For CL/APM, using the Advanced Process Module point's detailed display to load the object file into the APM.

Detailed instructions for these activities are in the following publications:

In the *Implementation/AM - 3* binder:

- *Control Language/AM Overview*
- *Control Language/AM Reference Manual*
- *Control Language/AM Data Entry*

In the *Implementation/APM- 2* binder:

- *Control Language/APM/Parameter Reference Dictionary*
- *Control Language/APM Data Entry*

## 4.8 AREA DATABASE CONFIGURATION

An Area Database (Area 01) is preconfigured for the Enhanced Micro TDC 3000 file. It uses the standard prebuilt data points described in Appendix A for Reports, Group displays, etc. You may want to look through the standard configuration data shown in subsection 4.7.2. If you loaded the standard points and do not need to change the Area Database configuration at this time, skip to subsection 4.9.

Area Database Configuration is accomplished through the activities listed on the Area Configuration Menu, which appears when the AREA DATA BASE target is selected on the Engineering Main Menu. Reference information for these activities is in *Area Form Instructions* in the *Implementation/Engineering Operations-1* binder. Area database entities are reserved entities that are built with the Data Entity Builder (DEB). Detailed DEB procedures are in the *Data Entity Builder Manual*, in the *Implementation/Engineering Operations - 1* binder. Paper forms SW88-579 through SW88-599 are also available to help you.

If you want to change only one or a few Area Database functions, probably the easiest way is to select that function on the Area Database Menu, type in the configuration you want, then press F12 (hold down CTL and press the ~ key). Note that if you get the message "Must Select An Area", perform steps 1 through 5 in 4.8.1.

If you want to rebuild the Area Database, Task 29 in the *System Startup Guide*, in the *Implementation/Startup & Reconfiguration - 1* binder, provides step-by-step instructions for a first-time configuration of an area database for a system that has not yet been started up (Tasks 1 through 28 are prerequisites).

### 4.8.1 Install the Area Database

If you made/loaded changes to the standard data base, the system will have created a working file. You must now install that file as follows—

1. If any Area Configuration function or the Area Menu is on screen, press the CMND key. If not, select BUILDER COMMANDS on the Engineering Main Menu.
2. Select SELECT AREA.
3. Key into the Reference Pathname port: NET>&D01>
4. Select AREA 1.
5. Key into the CURRENT AREA DATA BASE PATHNAME (if not already there):  
NET>&D01>AREA01
6. Select INSTALL AREA. The Reference Pathname port should contain:  
NET>&D01>. The Current Area Data Base Pathname and Pathname for Workfile ports should contain NET>&D01>AREA01.
7. Press ENTER. You should see a message:  
Operation Complete.

## 4.8.2 Area Database Prebuilt Configuration Data

The following data is in file AREA01 on the &D01 volume. It is presented in the same order as on the Area Configuration Menu.

### Unit Assignment Configuration

Units 01-10  
Unit IDs: 01 through 10  
Initially Assigned?: Units 01 through 10 YES

### Group Display Configuration

Group number: 1  
Group title: MICRO TDC 3000  
Points: AM\_REG, APM\_REG,  
APM\_AIF, APM\_AOF, APM\_AIC,  
APM\_AOC, APM\_NUM, APM\_FLG  
In the trend set? NO (all 8 points)  
Default trend timebase: 20 MINUTES

#### Associated Display Definition:

Screen 0, Type DETAIL  
Point ID PM\_SEG

#### Help Display Definition:

Screen 0, Type PMSTAT  
Process NTWK No.: 1, Box/Node: 3

Group number: 2  
Group title: MICRO TDC 3000  
Points: APM\_RPV, APM\_LOG,  
APM\_DC, APM\_DIF, APM\_DIC,  
APM\_DOC, APM\_TMR,  
In the trend set? NO (all 7 points)  
Default trend timebase: 20 MINUTES

#### Associated Display Definition:

Screen 0, Type DETAIL  
Point ID: APM\_SEQ

#### Help Display Definition:

Screen 0, Type PMSTAT  
Process NTWK No.: 1, Box/Node: 3

### Unit Trend Display Configuration

Trend display number: 1  
Trend title: MICRO TDC 3000  
Trend timebase: 2 HOURS  
Axis set definition: not configured  
Related/Help Displays: Null

### System Status

Associated Display Definition:  
Screen number: 0  
Display type: SCHEM  
Schematic name: NCF\_STS1

#### Help Display Definition:

Screen number: 0  
Display type: SCHEM  
Schematic name: KEYLOCK

### Reports

Not Configured

### Pathname Catalog Configuration

Button Config.File Vol. ID: &D01  
File Name: BUTTON01  
Schematic Pathnames:  
NET>PICS \$F1>PICS \$F2>PICS  
\$F1>DIA1 \$F2>DIA1 NET>&DSY

### Process Module Group

Group number: 1  
Group title: MICRO TDC 3000 CL PROGRAM  
Process Module ID: APM\_SEQ

Related Display: 001: Screen 0, Type PMSTAT  
Process NTWK No.: 1, Box/Node: 3

Related Display: 002: Screen 0, Type MSGSUM

Related Display: 003: Screen 0, Type UNITSUM

**Module Summary Display Configuration**

Line 1: HEADER  
 Title: MICRO TDC 3000 PROGRAMS  
 Line 2: BLANK  
 Line 3: MODULE  
 Module ID: APM\_SEQ  
 Lines 4-21: BLANK  
 Page 3: Screen 0  
 Disp. Type: MODGROUP  
 Group Number: 1

**Annunciator Display Configuration**

Box number: 1, Number of points: 2  
 Box title: UTDC 3000  
 Point names: AM\_REG, APM\_REG  
Related Display: Screen 0, Type ALARMSUM  
Associated Display: Screen 0, Type GROUP  
 Group No.: 1, Slot/IOM No.: 0  
Help Display: Screen 0, Type PMSTAT  
 Process NTKW No.: 1, Box/Node: 3

**Process Journals**

No. 1, Journal Name: ALARMS  
 Journal Title: MICRO TDC3000 ALARMS  
 Journal type: ALARM, Invoc. type: DEMAND  
 Ptr ID: 1, Time Span: 72,  
 No. Units: 10, Units: 1-10

No. 2, Journal Name: MESSAGES  
 Journal Title: MICRO TDC3000 MESSAGES  
 Journal type: OPERMSG, Invoc. type: DEMAND  
 Ptr ID: 1, Time Span: 72,  
 No. Units: 10, Units: 1-10

No. 3, Journal Name: CHANGES  
 Journal Title: MICRO TDC3000 OPERATIONS  
 Journal type: OPERCHG, Invoc. type: DEMAND  
 Ptr ID: 1, Time Span: 72,  
 No. Units: 10, Units: 1-10

**System Journals**

No. 1, Journal Name: SYSTEM1  
 Journal Title: MICRO TDC3000 SYS STATUS  
 Journal type: SYSSTAT, Invoc. type: DEMAND  
 Ptr ID: 1, Time Span: 72,

No. 2, Journal Name: SYSTEM2  
 Journal Title: MICRO TDC3000 SYS ERRORS  
 Journal type: SYSERR, Invoc. type: DEMAND  
 Ptr ID: 1, Time Span: 72,

No. 3, Journal Name: SYSTEM3  
 Journal Title: MICRO TDC3000 SYS MAINTS  
 Journal type: SYSMAINT, Invoc. type: DEMAND  
 Ptr ID: 1, Time Span: 72,

**Real-Time Journal Assignment Configuration**

Journal type:  
 Process Alarms: Initially active? YES  
 Oper. Process Chgs.: Initially active? YES  
 Oper. Messages: Initially active? YES  
 Syst. Status Changes: Initially active? YES  
 System Error Msgs.: Initially active? YES  
 System Maint. Msgs.: Initially active? YES  
 Printer ID (all journal types): 1

**Overview Configuration**

Group numbers: 1, No. of fields: 1  
 Field definition: Index 01  
 Field title: MICRO TDC3000  
 Top left element: 1,  
 Width 6, Height 4

Related Display 001 Definition:

Screen number: 0  
 Display type: NULL

Associated Display Definition:

Screen number: 0  
 Display type: NULL

Help Display Definition:

Screen number: 0  
 Display type: NULL

**Area Trend Display Configuration**

Trend title: MICRO TDC3000 AREA TREND  
 Trend timebase: 8 HOURS  
 Axis set definition: not configured

**LCN Node Annunciation Policy**

Annunciation policy  
 Address annunciated?:  
 Addresses 01 through 08: YES  
 Addresses 09 through 64: NO

The Following Not Configured:

Batch Summary  
 Standard Log  
 Printed Trend  
 SOE Journal Assignment



## 4.9 CONFIGURATION COMPLETION

The next step is to switch to the Operating Personality on a Universal Station (US). Other than standard software, the (US) requires a Network Configuration File, Configurable Button File, and Area Database file to load the US Operating personality. These should all be available at this point.

If there are two or more Universal Stations go to subsection 5.1.1.3, How to Load a US from Another Operating US. You may want to stay the Engineering mode in one and load the Operator's Personality in the other. If the memory size for US's is 6Mb or larger, then you may want to load the Universal Personality in one or all stations. The Universal Personality allows you to switch between Operating mode and Engineering mode with a single keystroke.



## OPERATIONAL GUIDELINES

### Section 5

*This section provides guidance for the operation of the Enhanced Micro TDC 3000 system. Node loading and area change procedures are provided which are tailored for the Enhanced Micro TDC 3000 system, and references are made to additional operating guidelines and instructions.*

#### 5.1 THE ENGINEERING AND OPERATOR PERSONALITIES

Each Universal Station (US) in a basic Enhanced Micro TDC 3000 system can be loaded with either the Universal Personality or the Operator Personality. When the Universal Personality is loaded in a station, both operations functions and engineering (configuration) functions can be performed. If the Operator Personality is loaded, only operations functions can be performed.

The Universal Personality is used to implement (or configure) the system to meet the needs of its particular application. Implementation Guidelines for the Enhanced Micro TDC 3000 system are provided in Section 4.

The Operator Personality is used by process operators and supervisors for day-to-day operation of the system and management of the process. It is also used by process engineers to verify operations and control strategies and to see the results of implementation activities that were accomplished in the Universal Personality.

Detailed operating instructions for engineering functions within the Universal Personality are provided in several data-entry publications in the *Implementation* binders. Detailed operating instructions for the Operator Personality or operations functions within the Universal Personality are provided in the *Process Operations Manual* in the *Process Operations* binder. In that binder you should also find a plastic envelope that contains a pocket-sized *Operator's Digest*.

##### 5.1.1 How to Load and Change US Personalities

The easiest way to change the personality of a US is through the Console Status display on another US. If there is only one US or if there are two USs, but neither one is running, a "bootload" procedure must be used to load a personality into a US.

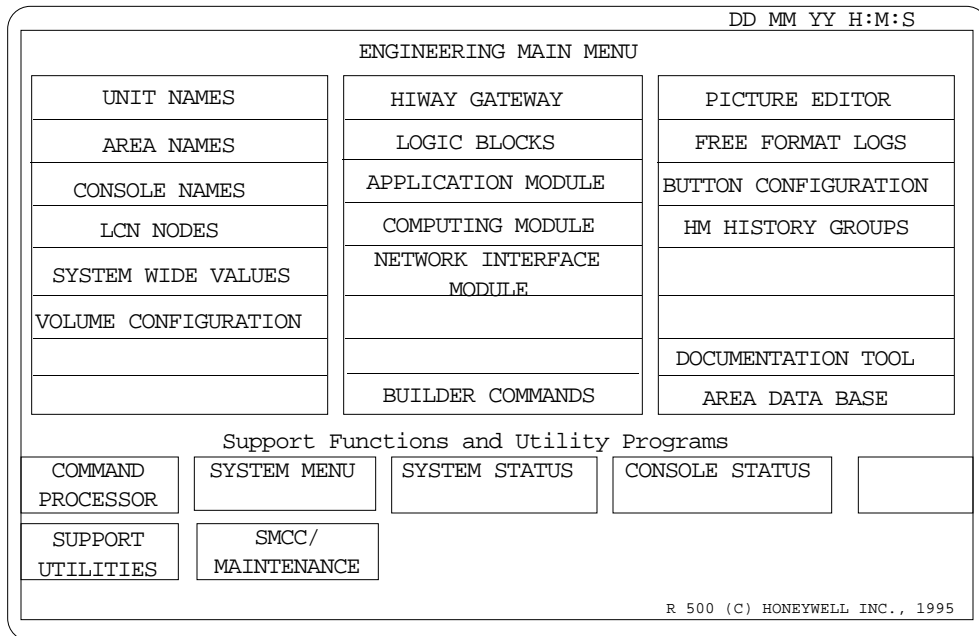

54121

The Engineering Main Menu is shown above. This display is available when the Universal Personality is loaded on a station.

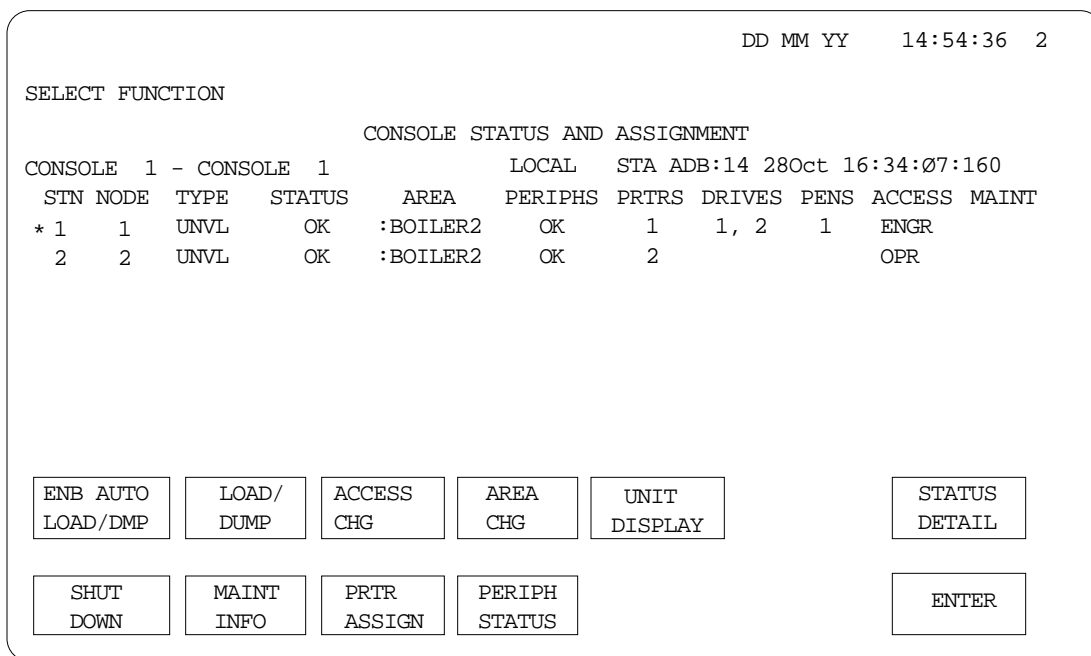

54122

The Console Status display is available in both the Operator Personality and the Universal Personality. This is the first display to appear when a station is loaded.

**Selecting**—In the pages that follow, when instructed to **select** something on the display, do so by moving the cursor onto the target and then press the SELECT key on the appropriate keyboard. If you have the optional touchscreen, touch the target to move the cursor onto the target; the select is performed by removing your finger from the display. If you have the optional trackball, position the cursor onto the target with the trackball and press the select key on the trackball. When instructed to **enter** something, move the cursor to the appropriate port, key in (type) the data, and then press the ENTER key on the appropriate keyboard or on the trackball. In Section 5, use the Operator's keyboard unless otherwise instructed. On the trackball, the right-hand key is the Select key and the left-hand key is the Enter key.

#### 5.1.1.1 How to "Bootload" US 1 with the Universal Personality from a Preloaded HM

The HM has been factory loaded, configured, initialized, with the volumes, directories, and data defined in Table 4-1, you can apply power and let it "boot" itself up (autoboot). To do this, after the tower 2 (left tower) power switch has been off for at least several seconds, turn it on. After several seconds, the three-digit-LED status indicator for the HM should show the node number "6." (The HM is the node C position, board slots 7 and 8, in tower 2. For more information, refer to Table 6-1.) Wait about five minutes before attempting to start up the US.

#### NOTE

Startup is the only situation where an HM should be forced to autoboot by turning power off and then back on. After a US is running, you can use the HM Status display (with the ENABLE LD/DMP status set to ENABLE) to twice SHUT DOWN the HM (for instructions, refer to the Process Operations Manual). This forces the HM to do an orderly shutdown and then to fail and autoboot.

If no US is running, do the following to start up a US with the Operator or Universal Personality:

1. If it is not already off, turn off the power switch on tower 1 (the right tower) for a few seconds and then back on. This resets the nodes in that tower, including US number. 1. Wait for > to appear in the upper left corner of the screen of the monitor connected to tower 1.
2. On the Operator's Keyboard, press LOAD. N , 1 , 2 , 3 , 4 , X appears.
3. Press the ALPHA SHIFT key, (until the LED comes on), key in N, then press ENTER. Several messages appear, ending with OPR , UNP?? (UNP is for Universal Personality.)
4. Key in OPR or UNP. Press ENTER. If you make a typing mistake, either use the back arrow key or left tab to recover.
5. Wait a few minutes for the Console Status display to appear. If it doesn't appear within five minutes, the HM probably did not autoboot, in which case, you should try to load the system from cartridges. Refer to 5.1.1.2 for the procedure.

#### NOTE

**Beeping Noise**—As the US Operating Personality comes up, you may hear a beeping noise indicating that some alarm needs to be evaluated and acknowledged. For now you can stop the noise by pressing the SIL (silence) key.

If the Console Status display is on screen, go to subsection 5.1.1.5, Setting the Time and Date.

#### 5.1.1.2 How to “Bootload” a US with the Operator Personality from Cartridges

1. If it is not already off, turn off the power switch on tower 1 (the right tower) for a few seconds and then back on. This resets the nodes in that tower, including US no. 1. Wait for > to appear in the upper left corner of the screen of the monitor connected to tower 1.
2. Mount the Honeywell-provided cartridge labeled &C2 in drive 1 (the top drive).
3. On the Operator’s Keyboard, press LOAD. N , 1 , 2 , 3 , 4 , X appears.
4. Key in 1, then press ENTER. Several messages appear, ending with OPR , UNP??
5. Press the ALPHA SHIFT key (until the LED lights), then key in OPR and press ENTER. Several messages appear, ending with NCF? N , 1 , 2 , 3 , 4 , X .
6. Mount cartridge &C8 with the prebuilt NCF in drive 2.
7. Key in 2, then press ENTER. This specifies drive 2 as the source of the NCF. After a few minutes, the message: AR01? N , 1 , 2 , 3 , 4 , X? should appear.
8. Key in 2, then press ENTER. This specifies drive 2 as the source of the Area Database. After a few minutes, the message: ABST? N , 1 , 2 , 3 , 4 , X? should appear.
9. Key in 2, then press ENTER. This specifies drive 2 as the source of the abstracts. After a few minutes, the message: BUTT? N , 1 , 2 , 3 , 4 , X? should appear.
10. Key in 2, then press ENTER. This specifies drive 2 as the source of the Configurable Button file.
11. Wait a few minutes for the Console Status display to appear. If the Console Status display is on screen, go to subsection 5.1.1.5, Setting the Time and Date.

If the display doesn’t appear within five minutes, something went wrong. Here are some suggestions for recovery:

- Try the procedure again.
- Refer to the *Process Operations Manual* for information about status conditions that affect the ability of a US to load.
- Refer to Section 20 of the *Engineer’s Reference Manual*. This section has information about causes of node loading failures, and memory dumps that may be necessary to analyze such failures.
- Use the *System Startup Guide* to start up the Enhanced Micro TDC 3000 System.

### 5.1.1.3 How to Load a US from Another Operating US

This procedure requires an operating HM that has been configured, initialized, and loaded with the volumes, directories, and data defined in Table 4-1.

1. Call up the Console Status Display. To do this, from the Engineering Personality Main Menu, select `CONSOLE STATUS`, or in the Operator Personality, press the `CONS STATUS` key.
2. Select the node number for the US to be loaded. The node number turns white.
3. If the status for the US to be loaded is `FAIL`, `READY`, `PWR_ON`, or `QUALIF`, skip to step 4. Otherwise, select `SHUT DOWN`, and press `ENTER`. This shuts down and resets the other US.
4. If `AUTOLOAD NET` target is present, select `AUTOLOAD NET` and press `ENTER`, (to load the Operator Personality) and skip to step 6. Otherwise, select `MANUAL LOAD`. Four new targets appear. Continue with step 5.
5. Select either the `OPERATOR PROGRAM` or `ENGINEER PROGRAM` or `UNIVERSAL PROGRAM` target, then follow the prompts that appear to select the default source (`NET = HM`) for the program source and data source.
6. Wait for the Console Status display (Operator or Universal Personality) or the Engineering Personality Main Menu (Engineering Personality) to appear. If the Console Status display is on screen, go to subsection 5.1.1.5, Setting the Time and Date.

If the menu does not appear within 5 minutes, something went wrong. Here are some suggestions for recovery:

- Try the procedure again.
- Refer to the *Process Operations Manual* for information about status conditions that affect the ability of a US to load.
- Refer to Section 20 of the *Engineer's Reference Manual*. This section has information about causes of node loading failures, and memory dumps that may be necessary to analyze such failures.
- Use the *System Startup Guide* to start up the Enhanced Micro TDC 3000 System.

### 5.1.1.4 How to Change a US's Personality

If you have the Universal Personality loaded, you can switch between operations functions and engineering functions by holding down the Control key and pressing the Help key on the Engineering Keyboard.

If you have two operating USs, use the steps under 5.1.1.3 to load one station from the other. If you have only one US, use the procedure under 5.1.1.1 or 5.1.1.2 to reset it and load it with the Operator Personality or the Universal Personality.

### 5.1.1.5 How to Set the Time and Date

1. Press the SYSTEM STATUS display key on the Operator's Console. On the System Status display, select the TIME/DATE target.
2. A port opens with a prompt to enter the time. Key in the time in hours and minutes (for example, 14 25).
3. Press ENTER and the current time should appear in the upper right corner.
4. A port opens with a prompt to enter the date. Key in the current day, month and year (for example, 15 OCT 91).
5. Press ENTER and the current date should appear in the upper right corner.

## 5.2 LOADING THE MODULES AND GATEWAYS

At this point, at least one US should be running the Operating Personality. If you went through the implementation procedures in Section 4 of this manual, the modules should already be loaded and running. If you didn't go through the steps in Section 4 (or if you just want to check the modules), press the SYST STATUS key on the Operator's Keyboard. Select the HISTORY MODULES target. If it doesn't have a status of OK you should not continue until the problem is fixed.

Return to the System Status Display either by pressing the PRIOR DISP key or the SYST STATUS key. One by one, select the other module and gateways targets on the System Status display and check each implemented module for a status of OK (OK indicates the Operating Personality is running in the module). An unimplemented module has a status of OFF. An implemented but unloaded module usually has a status of PWR ON.

If any implemented module does not have a status of OK, use the following procedures to load the module. Refer to 5.1.1.3 to load another Universal Station.

If the system has an optional CG or PLCG, refer to Section 18 in the *System Startup Guide—Cartridge Drive* for the module loading procedures.

### 5.2.1 Loading the Application Module

The Application Module is loaded through the Application Modules Status display, which is called up by selecting APPLICATION MODULES on the System Status display.

1. Select the node number 5 (the AM).
2. If the AUTOLOAD NET target is present, select AUTOLOAD NET, press ENTER, and skip to step 4. Otherwise, select MANUAL LOAD. Continue with step 3.
3. Select OPERATOR PROGRAM, and follow the prompts to specify the program and data source [normally, you will select the default source (NET = HM)]. Then, select EXECUTE COMMAND.
4. Wait from a few seconds to a few minutes for the status for the AM to go to OK.



## 5.2.2 Loading Network Interface Module and UCN Devices

The Network Interface Module is loaded through the Gateways and Interfaces Status display, which is called up by selecting GATEWAYS on the System Status display.

1. Select the node number 3 (primary) or 4 (redundant) for the NIM to be loaded.
2. If the AUTOLOAD NET target is present, select AUTOLOAD NET , press ENTER, and skip to step 4. Otherwise, select MANUAL LOAD. Continue with step 3.
3. Select OPERATOR PROGRAM, and follow the prompts to specify the program source [normally, you will select the default source (NET = HM)]. Then, select EXECUTE COMMAND.
4. Wait from a few seconds to a few minutes for the status for the NIM you selected in step 1 to go to OK .

MAKE SELECTION				24 Feb 15:50:06 1			
UCN CABLE STATUS: OK				UCN 10 STATUS		UCN CONTROL STATE: BASIC UCN AUTO CHECKPNT: INHIBIT NIM AUTO CHECKPNT: DISABLE	
01 NIM 02 OK BACKUP	03 PM 04 OK BACKUP	05 PM 06 ALIVE ALIVE	07 LM 08 OK BACKUP				
LOAD/SAVE RESTORE	CONTROL STATES	AUTO CHECKPT	UCN CABLE STATUS	RUN STATES	SLOT SUMMARY	DETAIL STATUS	
PROGRAM LOAD	RESTORE DATA	SAVE DATA	LADDER LOAD	LADDER SAVE	CANCEL	ENTER	

53290

When the NIM is loaded and operating (primary NIM status = OK), you can load the APM program and restore Advanced Process Manager data through the UCN status display. Refer to subsection 4.4 in this manual.

When the APM data has been restored, the modules may still be in an IDLE state. Check this by calling up the UCN Status display. You can call up the UCN Status display in one of two ways:

- On the System Status display, select the Process Network Status 1 target.
- On the Gateways and Interfaces Status display, select node 1, then select NTWK STATUS.

If the status is IDLE—

Select the 03 APM target.  
 Select the APM SYS COMMANDS target.  
 Select the STARTUP target.  
 Select ENTER. The status should change to OK. If there is a redundant PMM, its status should be BACKUP.

Detailed instructions for loading programs, and saving and restoring data for UCN devices are provided in Section 18 of the *Process Operations Manual*.

### 5.2.3 Loading the History Module

The History Module is configured, loaded, and initialized at the factory. Thereafter, it is able to load itself (to “autoboot”) after its operation is interrupted, provided that it had not had a failure from which it cannot recover. For example, if the ac power supply to the HM is interrupted and then returns, the HM normally autoboots, and returns to normal operation, showing a status of OK on the History Modules Status display.

If, for some reason, you do not want the HM to autoboot, on the History Modules Status display, select 6 (the HM node number), select ENABLE LD/DUMP, and select DISABLE. This disables HM autobooting until the Enable Load/Dump status is changed back to ENABLE. If you need to reload the HM, refer to the *System Startup Guide*.

## 5.3 SYSTEM OPERATION

At this point, the system should be up with all modules running. You should remove any cartridge disks from the drives. The *System Overview* in the *System Summary* binder provides a description of overall system operations, including descriptions of the use of standard and custom (graphic or schematic) displays and other human-interface features to monitor, control, and manage a process. If you are new to LCN-based TDC 3000<sup>X</sup> Systems, we recommend that you read the following sections in the *System Overview*:

- Section 5—Man/Machine Interface
- Section 6—System Operation
- Section 8—System Maintenance

### 5.3.1 Calling Up Operating Displays

If you have either loaded the prebuilt checkpoints or built and loaded a few other points, you should be able to call up some of the operating displays at a Universal Station.

#### 5.3.1.1 To Call up a **Detail Display**

- Press the DETAIL Display key on the Operator's Keyboard.
- A port appears after the message: Enter Point ID \_\_\_\_\_.
- Press the Alpha Shift key (the indicator comes on in alpha mode).  
Key in a point ID. For example PM\_REG. (see Appendix A for a list of the prebuilt points).
- Press ENTER. The Detail display should appear for this point.

#### 5.3.1.2 To Call Up a **Group Display**

- Press the GROUP Display key on the Operator's Keyboard.
- A port appears after the message: Enter Group No. \_\_\_\_\_.
- Key in a Group number. For example 1; then press ENTER. (Groups 1, 2, and 401 are available on standard systems and you can build other groups).

#### 5.3.1.3 **Other Displays**

Detailed descriptions of Operator Personality operations and all standard displays are provided in the *Process Operations Manual* in the *Process Operations* binder. This binder is shipped with a plastic envelope that contains a pocket-sized *Operator's Digest*.

You may want to press the SYST MENU key and browse through the displays that can be selected on this menu.

### 5.3.2 The Area Database

Each Universal Station with the Operator Personality operates on an Area Database that defines for the US,

- Process units assigned to it.
- Pathnames for custom displays and button configuration files.
- Process-related and use-related characteristics of standard displays, standard logs, Free Format logs, printed trends, reports, and journals.
- Alarm annunciation policies.

It is relatively easy to make changes to the Area Database (for more information, see 4.8), but to make such changes effective it necessary to reload the new, modified Area Database. In some situations, a US may from time-to-time need to operate in a different process area, using a different Area Database. To reload a modified Area Database or to change to a different Area Database, use the following procedure.

#### 5.3.2.1 How to Change the Area Database

1. At a US running the Operator Personality, on the Console Status display select AREA CHANGE, then select the target for the new area or the area whose database has been modified. A new display appears with targets to select the default Area Database source (NET = HM) or the alternate source (cartridges).
2. If the Area Database is on the HM (normally, it will be), select NET. Otherwise, select ALTERNATE SOURCE and select the cartridge drive with the Area Database.
3. Select EXECUTE COMMAND. AREA CHANGE IN PROGRESS appears and after several seconds the Console Status display reappears.

### 5.3.3 Keyswitch Access Levels

All functions that can change data within the Enhanced Micro TDC 3000 System are assigned by Network Configuration, or by the system, to one of these keyswitch access levels:

- Operator
- Supervisor
- Engineer

Universal Stations on other TDC 3000<sup>X</sup> Systems have a 3-position keyswitch. The ability of an individual to change the position of the keyswitch, and therefore, to have the ability to change certain types of data, depends on the key he or she holds. Engineer keys can move the switch to any position, supervisor keys can move it to the Operator and Supervisor positions, and the key can be removed only in the Operator position.

Because a keyswitch is not provided on the Enhanced Micro TDC 3000 System, a password-protected display is provided to allow authorized people to change the keyswitch (access) level. The content of the display is affected by the password used. Those with operator-access authority are given no password, those with supervisor-access authority are given a supervisor-access password, and those with engineer-access authority are given an engineer-access password.

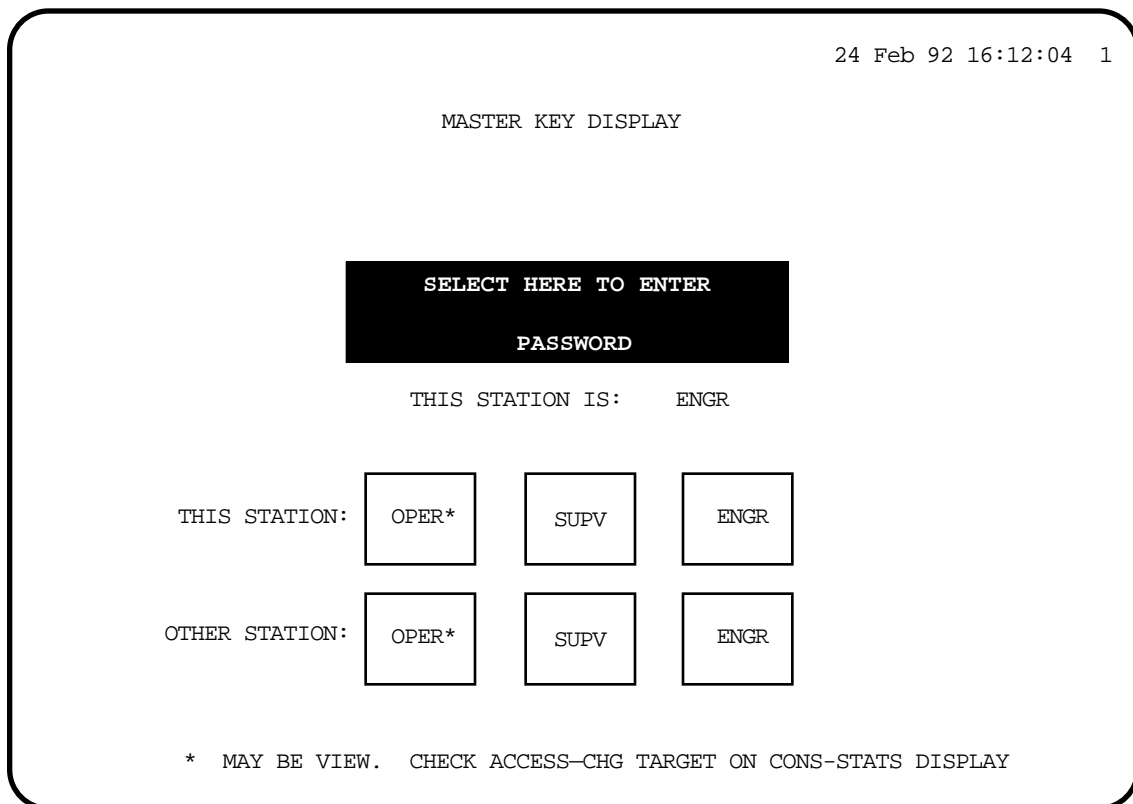

11232

To call up the display at a US running the Operator Personality, with the System Status display on the screen, press HELP. This display appears with the OPER\* target, but without the SUPV and ENGR targets. You can select OPER\* to change to the operator keyswitch level.

To change to supervisor or engineer keyswitch level, select the TOUCH HERE TO ENTER PASSWORD target, key in the password, and press ENTER. If you use an Engineer's Keyboard, you must use capital letters. If you are in the Universal Personality and want to go from operator keylock level to engineer keylock level, press PF1 on the Engineer's Keyboard.

SUPV or SUPV and ENGR targets appear. Select the desired access level. The "THIS STATION IS:" line changes to indicate the new keyswitch level.

The prebuilt passwords in systems shipped from the factory are TDC3000 SUPV and TDC3000 ENGR (be sure to key in the space). You can call up the display as schematic KEYLOCK.

The line that reads, "\*MAY BE VIEW. CHECK ACCESS-CHG TARGET ON CONS-STATS DISPLAY," reminds users that in Network Configuration, under System Wide Values, the Default Access Level for this US may have been configured as VIEW (no database changes allowed), rather than OPER, so selecting OPER results in the VIEW level. To verify the actual keyswitch level for this US, call up the Console Status display and check under the ACCESS heading.

### 5.3.3.1 Keylock Graphic Files

The following files are provided in the PICS volume to support the KEY\_LOCK display:

- KEYLOCK.DS        Display source file
- KEYLOCK.DO        Display object file
- S\_OPER            Operator target subpicture
- S\_SUPV            Supervisor target subpicture
- S\_ENGR            Engineer target subpicture

You can incorporate the subpictures in any of your custom displays, to allow keyswitch-level changes from those displays.

For information about the picture editor, refer to the *Picture Editor Reference Manual* in the *Implementation/Engineering Operations - 2* binder and *Picture Editor Data Entry* in the *Implementation/Engineering Operations - 3* binder.

### 5.3.3.2 Changing the Password

At a US with the Universal Personality running and an Engineering Keyboard connected, you can use the Picture Editor to edit the KEYLOCK source file to change the passwords, and then recompile the picture to make the new passwords effective. The general procedure is (press Enter after each command):

- Read the source file into the Picture Editor. The command is  
Read Net>&PICS>Keylock.
- Key in the command: Set Textsize Large.
- Select the SUPV box. The command is Select Variant. Move the cursor just above the SUPV box and press the Select key. Move the cursor just below the SUPV box and again press the Select key. When you press ENTER, the SUPV box should turn white and blink.
- Key in the command: Modify Variant.
- When the Variant screen Form appears, locate the words in quotation marks. These are the passwords. "TDC3000 SUPV" is the string for Supervisory level, and "TDC3000 ENGR" is the string for Engineering level.
- Type a new character string over the old string to change the password for that authorization level (hold down CTL and press TAB to move the cursor). Delete extra letters or spaces within the quotes by pressing the DEL CHAR key. If you need to add letters, press the INS CHAR key first. Lowercase letters can be used only on a US with an Engineer's keyboard, so do not use them in a password if the password must be entered from a US that has only an Operator's keyboard.
- Press ENTER after all the changes have been made. The keylock picture returns.
- Compile the picture. The command is: Compile Net>&D01>Keylock.

At a station with the Operator Personality running, perform the Area Database change procedure except select the same area that was running before. You must either do this or reload the US to make the newly compiled keylock picture available.

## 5.4 MONITOR OPERATION

The Enhanced Micro TDC 3000 may be using one of following types of monitors:

- IDEK 21-inch Multiscan Color Monitor (older monitor Model MF-5221). Section 5.4.1 explains the analog, rotary-type screen control knobs.
- IDEK 21-inch Vision Master Monitor (newer monitor Model MF-8221). Section 5.4.2 explains the digital, push-button screen controls.
- HITACHI 21-inch Color Monitor (Model HM-4821-D). Section 5.4.3 explains the screen controls. This monitor meets CE requirements. It must be ordered separately using model number MX-MTMA21.

The newer IDEK monitor is essentially identical to the older monitor including the touchscreen option. There are small physical differences between them primarily in the layout and location of the screen controls. The new monitor has its screen controls mounted inside a recessed, sliding tray (drawer) located below the screen. The screen controls on the new monitor cannot be accessed once the drawer is closed (pushed in). The overall dimensions of the newer monitor are slightly larger than the older monitor. Electrically, the video cable plug and pinning are identical in both.

Both IDEK monitors have an optional touchscreen (infrared touchscreen frame with plastic bezel assembly) which are physically different. The touchscreen option for the newer monitor has 4 mounting 'buttonholes' (two on each side), and is only compatible with the newer monitor. The older monitor has 2 'buttonholes' (one on each side). The touchscreen controller (electronics) and cable for the new monitor is identical to the older monitor and can be easily transferred.

Table 5-1 shows the touchscreen hardware used with each monitor. The only difference between the two IDEK monitors is the larger Bezel for the newer IDEK Model 8221. The Hitachi uses the same touchscreen frame as the IDEK monitors.

**Table 5-1 — Touchscreen Hardware Vs Monitor Used**

Touchscreen Components	Hitachi HM-4821-D 51197021-100	IDEK 8221 51196363-100	IDEK 5221 51196075-100	MITSUBISHI HC3905ATK 51195652-100
T/S Controller	51197005-100	51197005-100	51197005-100	
Cable: EPDGP I/O to Controller	51302287-100	51302287-100	51302287-100	51306150-100 ② TS Power Cable
Cable: Controller to Touchscreen	51302297-100	51302297-100	51302297-100	51306151-100 ② TS Data Cable
Touchscreen w/Bezel	51197022-100④	51197019-100④	51197007-100④	51195992-100
Bezel only	51197022-300③	51197019-200①		
Bezel mounting buttons-pkg of 4	51197022-400	51197019-300①		
<b>Notes:</b>				
① These two items are required when moving a touchscreen from an IDEK model 5221 to a IDEK model 8221. The IDEK 8221 requires a slightly larger plastic bezel housing. The same touchscreen (sensor) frame is used in both IDEKs and the Hitachi. The four stick on buttons physically secure the touchscreen to the monitor.				
② These cables go from the touchscreen to the I/O card in the node chassis.				
③ Includes the 4 mounting buttons. This Bezel will adapt either IDEK touchscreen to fit the Hitachi monitor				
④ These assemblies all contain the same touchscreen. Only the Bezel is different.				

The following information describes the differences in layout and location of the screen controls for the different monitors.

### 5.4.1 IDEK Model MF-5221

Section 5.4.1 describes the operational controls of the IDEK 21-inch Multiscan Color Monitor (older monitor Model MF-5221). The numbered description of each analog, rotary-type screen control knobs are referenced to the identification number shown in Figure 5-1.

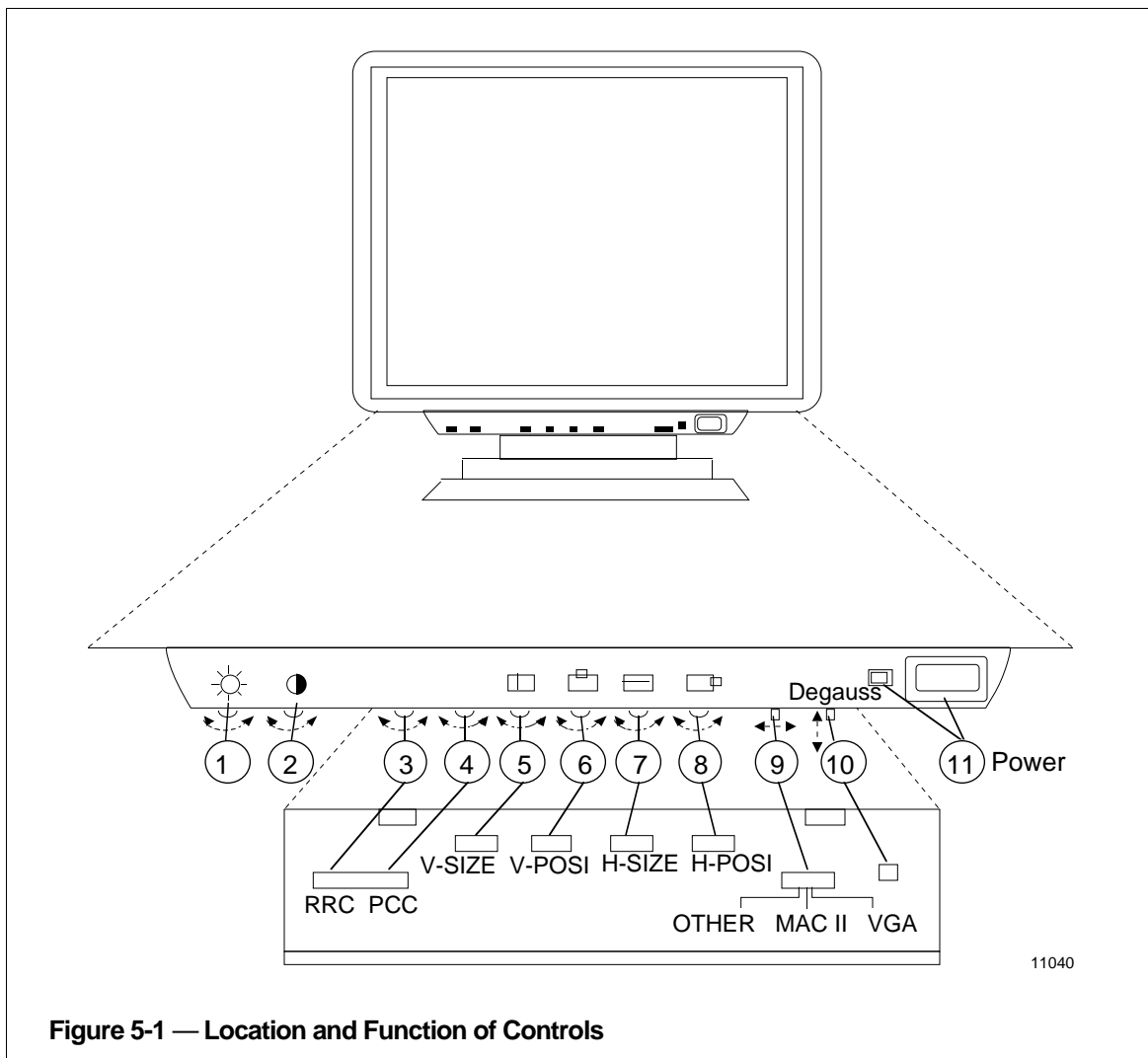

1. BRIGHT (brightness) control  
Turn this control to adjust the brightness of the display.

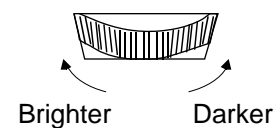



## 2. CONT (contrast) control

Turn this control to adjust the contrast of the display.

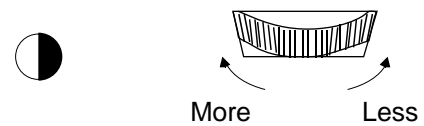

## 3. RRC (Raster Rotation Circuit) control

Turn this control to correct the raster tilt.

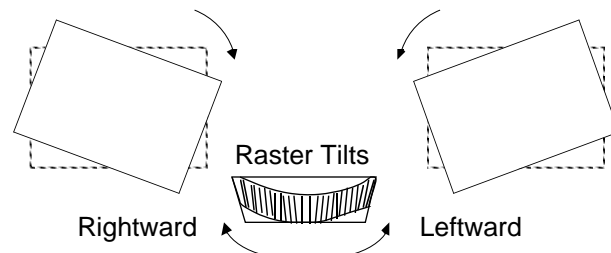

NOTE: Using this control also removes poor purity from around the CRT, which is generated when swiveling the unit.

## 4. PCC (Pincushion Correction Circuit) control

Turn this control to correct both right and left side distortion of the display.

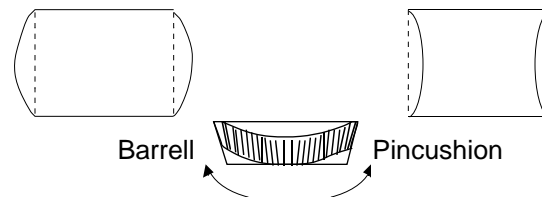

## 5. V-SIZE (vertical size) control

Turn this control to adjust the vertical size of the display.

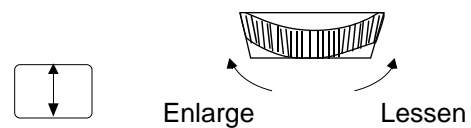

## 6. V-POSI (vertical position) control

Turn this control to adjust the center of the display vertically.

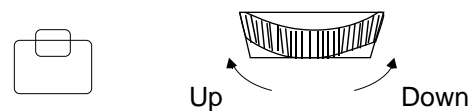

## 7. H-SIZE (horizontal size) control

Turn this control to adjust the horizontal size of the display.

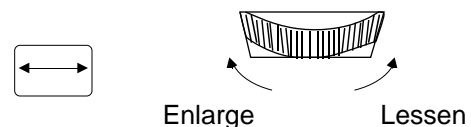

## 8. H-POSI (horizontal position) control

Turn this control to adjust the center of the display horizontally.

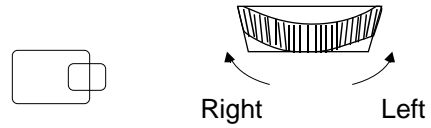

## 9. SIGNAL SELECT switch

VGA: Select VGA when using a VGA graphics card.

MACII: Select MACII when using an Apple Macintosh II (with the standard Apple Video card) or PGC graphics card.

OTHER: Select OTHER when using any other graphics card or generator than the above with a horizontal frequency between 30 and 80 kHz.

## 10. DEGAUSS button

Press this button to degauss CRT

## 11. POWER switch and indicator

To turn on the power of the unit, press this switch. The indicator will light up.

To turn off the unit, press it again.

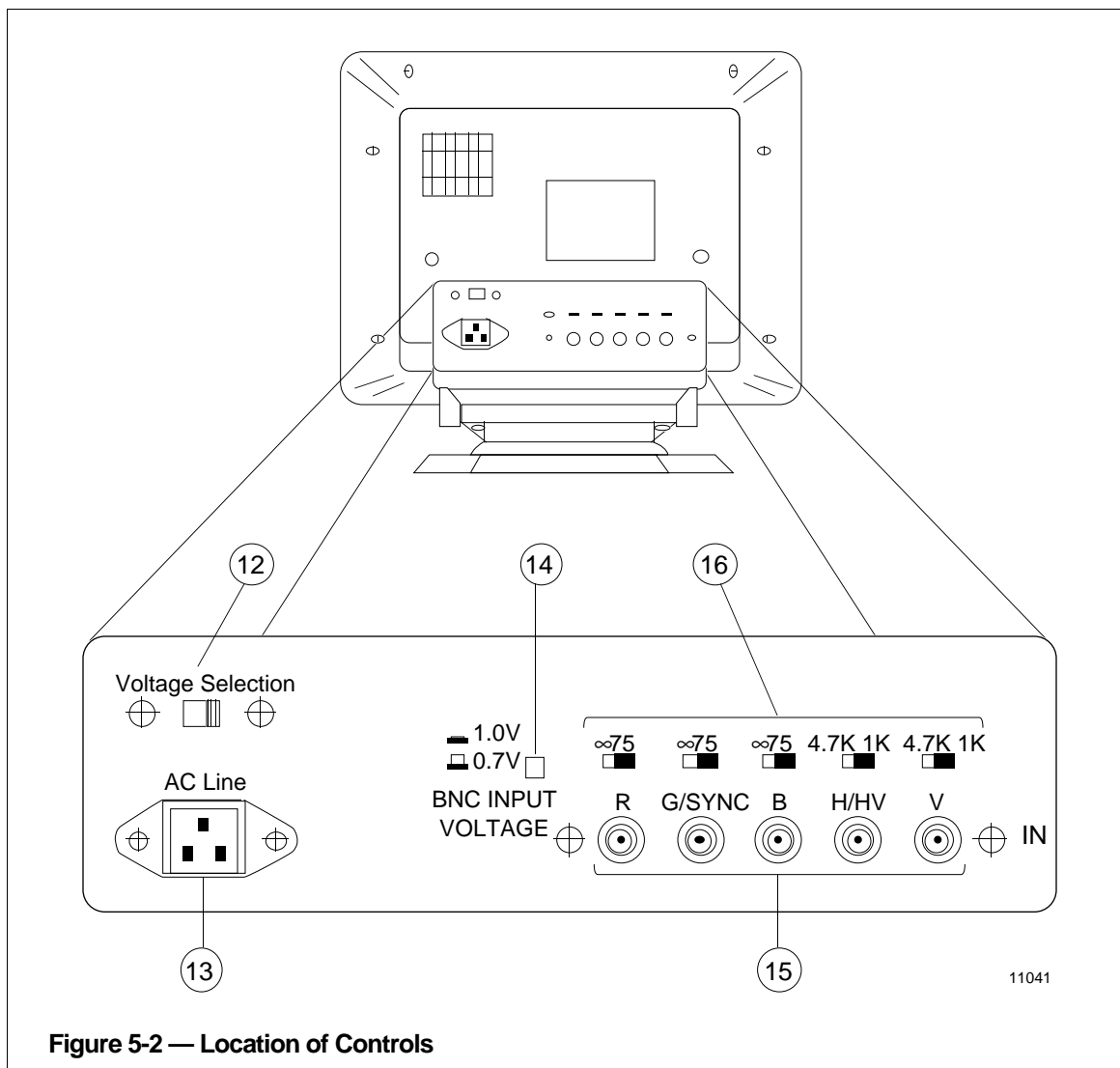

**Figure 5-2 — Location of Controls**

12. AC INPUT VOLTAGE selector  
Set to the local power line voltage, 115 V or 220 V.
13. AC INPUT connector  
Connect to the AC outlet with the supplied AC power cord.
14. BNC INPUT VOLTAGE selector  
Select the appropriate BNC video input voltage for your computer, 0.7 V or 1.0 V.

BNC INPUT VOLTAGE selector

■	1.0 V
■	0.7 V

## 15. ANALOG RGB INPUT connectors (5 BNC)

Allows a computer having analog RBG output to be connected.

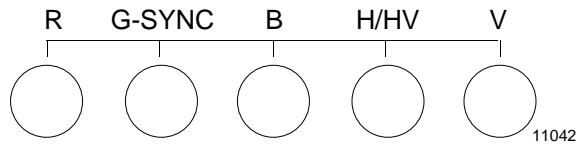

BNC analog signals

Connector	Sync on Green	Composite sync	Separate sync
R	Red	Red	Red
G/SYNC	Sync on Green	Green	Green
B	Blue	Blue	Blue
H/HV	GND/unused	HV sync	H-sync
V	GND/unused	GND /unused	V-sync

## 16. TERMINATION switches

Select the appropriate line impedance ( $75\Omega$  or infinity) for video and ( $1\text{ K}\Omega$  or  $4.7\text{ K}\Omega$ ) for sync.

If the monitor is used in a loop-through operation, set these switches to the left (infinity for video,  $4.7\text{ K}$  for sync). For single unit operation, or when the monitor is the last unit in a loop-through string, set these switches to the right ( $75$  for video,  $1\text{ K}$  for sync). The switches of unused BNC connectors should also be set to the right.

### 5.4.2 IDEK Model MF-8221

Subsection 5.4.2 describes the operational controls of the IDEK 21-inch Vision Master Monitor (newer monitor Model MF-8221). The numbered description of each of the digital, pushbutton screen controls make reference to the identification number shown in Figure 5-3.

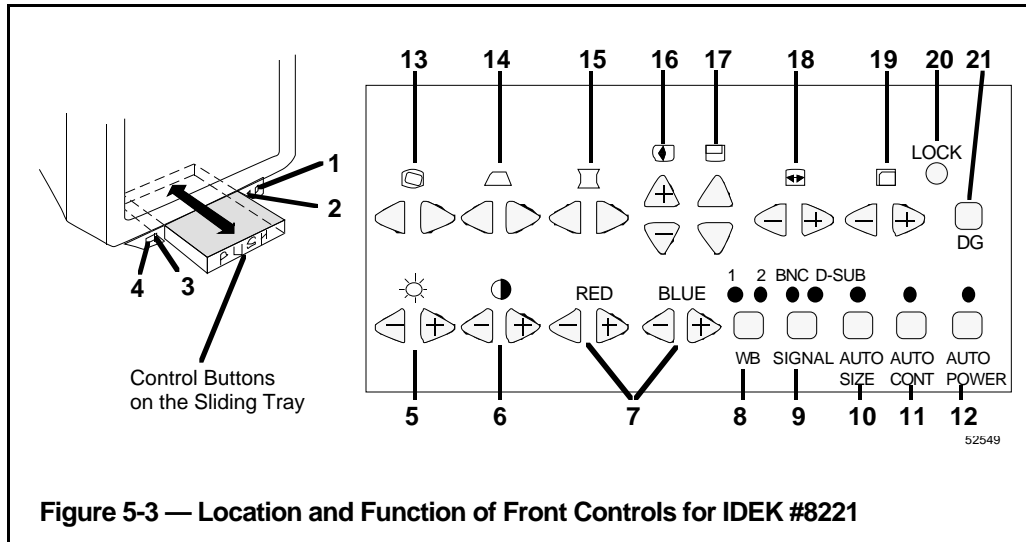
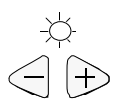

Figure 5-3 — Location and Function of Front Controls for IDEK #8221

1. **POWER SWITCH (ON/OFF)**
  - Use to turn the power ON or OFF.
  - Press the switch to turn ON and press it again to turn OFF.
2. **POWER/STANDBY INDICATOR**
  - Indicates power-ON/OFF or stand-by state.
  - When the power is ON, green light comes on, and it goes off when the power is OFF. When the AUTO POWER-OFF SENSOR is activated and switches to the stand-by state, the green light turns red.
3. **AUTO POWER-OFF SENSOR**
  - To save energy, it detects the presence of an operator and powers down to the standby state automatically when no one is in front of the monitor for over an hour.
  - To turn the power back on in the standby state, the following two ways are available:
    - One is to press the AUTO POWER-OFF setup switch.
    - The other is to press the POWER SWITCH and make sure the red light goes off. Then press it again and green light will come on.
  - Note: - Do not place anything in front of the sensor. It doesn't operate properly when it is dirty or covered.
4. **AUTO CONTRAST SENSOR**
  - To avoid eye strain and reduce energy, it adjusts the screen contrast automatically as the ambient light of the room changes.
  - Note: - Do not place anything in front of the sensor. It doesn't operate properly when it is dirty or covered.

## 5. BRIGHTNESS CONTROL BUTTONS

- 
- Press to adjust the picture brightness.
  - When you press the BRIGHTNESS CONTROL BUTTONS at the same time for over three seconds, you will hear a beep and the adjusted brightness will be canceled and set back to the factory setting “center.”

## 6. CONTRAST CONTROL BUTTONS

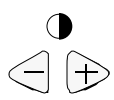
- 
- Press to adjust the picture contrast.
  - You will hear short beeps when the contrast reaches its maximum setting.

## 7. TONE CONTROL BUTTONS (RED/BLUE)

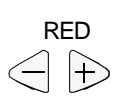
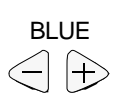
- 
- Use to adjust the white tone as you prefer, other than WB1/WB2 selectable by the WHITE SELECT BUTTON.
  - When the + button is kept pressed, the color tone becomes vivid gradually. When the - button is kept pressed, it fades gradually.
- 
- The user adjusted tone is automatically stored. It is recalled and readjustable by pressing either one of the TONE CONTROL BUTTONS once when using WB1/WB2.
  - You will hear a beep and the user adjusted tone will be canceled and set back to the factory setting “WB1” when you press the WHITE SELECT BUTTON for over three seconds.

## 8. WHITE SELECT BUTTON (WB1/WB2)

- 
- Use to select white balance either WB1 (9300°K: bluish white) or WB2 (6500°K: reddish white).
  - Pressing the button alternates between the white balances and the indicator will be illuminated in either case.
  - Neither indicator blinks when the user adjusted/adjustable tone is selected by pressing either one of the TONE CONTROL BUTTONS once.

## 9. SIGNAL SELECT BUTTON (BNC/D-SUB)

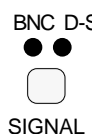
- 
- Use to select the input signal either from the BNC CONNECTORS or from the 15PIN D-SUB CONNECTOR.
  - Pressing the button alternates between the input connectors and the indicator will be illuminated in either case.

## 10. AUTO SIZE/POSITION SET UP BUTTON (ON/OFF)



- Use to operate or cancel the automatic horizontal and vertical picture sizing and centering function which recognizes the picture size and position according to the signal applied to the monitor and adjusts automatically.
- The indicator will be illuminated when the automatic function is on.
- While the automatic function is on, it operates every time you turn the power on or change the input signal. It is best to keep the button off when it is not necessary.

Note - When you operate the automatic function, you will need full-size picture information on the screen and the video input signal with the maximum brightness such as Windows screen. It may not operate properly with special picture information such as only a prompt C> on the screen.

- When the picture adjusted by the automatic function needs to be changed, operate the SIZE or POSITION BUTTON you desire to change.

## 11. AUTO CONTRAST SET UP BUTTON (ON/OFF)



- Use to operate or cancel the AUTO CONTRAST SENSOR.
  - The indicator will be illuminated when the sensor is in operation.
- Note - When set to ON it will automatically adjust the crt contrast as the ambient light of the room changes.

## 12. AUTO POWER-OFF SET UP BUTTON (ON/OFF)

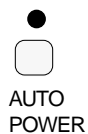

- Use to operate or cancel the AUTO POWER-OFF SENSOR.
  - The indicator will be illuminated when the sensor is in operation.
- Note - When set to ON it will sense the presence of an operator in front of the monitor. It will automatically power down the monitor when an operator is absent for more than an hour. The power indicator will be green in a normal operation and red when in stand-by-state. To restore operation, either cycle power or press the AUTO POWER button (cancels sensor).

## 13. RRC CONTROL BUTTONS

- Press to correct raster rotation or poor purity caused by magnetism when the monitor is swiveled while in operation.
- When you press the RRC CONTROL BUTTONS at the same time for over three seconds, you will hear a beep, and the adjusted condition will be canceled and set back to the factory setting "center."

Note: - The RRC CONTROL BUTTONS must be used after degauss has been operated.

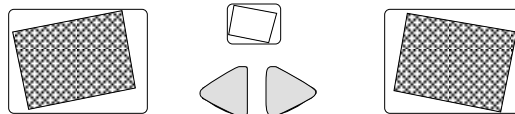

52542

## 14. TRAPEZOID CONTROL BUTTONS

- Press to correct trapezoid distortion and to produce parallel vertical edges.

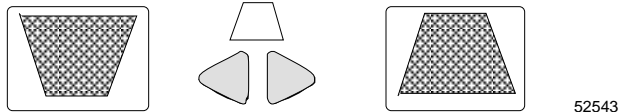

52543

## 15. PCC CONTROL BUTTONS

- Press to correct pincushion or barrel distortion and to produce straight vertical edges.

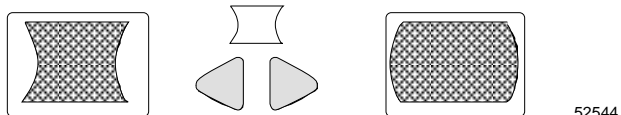

52544

## 16. V-SIZE CONTROL BUTTONS

- Press to adjust the vertical size of the picture.

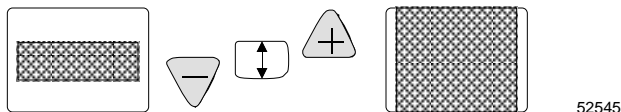

52545

## 17. V-POSITION CONTROL BUTTONS

- Press to adjust the vertical position of the picture.

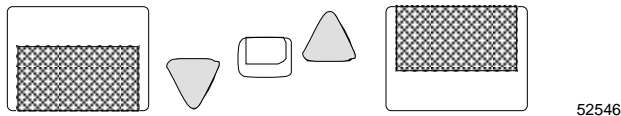

52546

## 18. H-SIZE CONTROL BUTTONS

- Press to adjust the horizontal size of the picture.

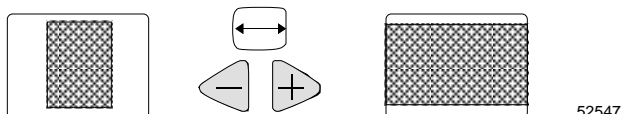

52547

## 19. H-POSITION CONTROL BUTTONS

- Press to adjust the horizontal position of the picture.

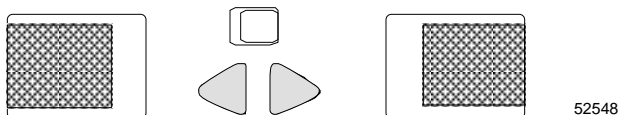

52548



## 20. LOCK BUTTON

- LOCK  

- Use to protect the picture information from unintentional operation of the control buttons.
  - When the LOCK BUTTON is pressed, you will hear a beep and the following control buttons will be locked and stop operating: TONE, AUTO SIZE/POSITION SET UP, RRC, TRAPEZOID, PCC, V-SIZE, V-POSITION, H-SIZE, H-POSITION.
  - When you try to use the locked control buttons, you will hear short beeps as an alarm.
  - To release the locked condition, press the LOCK BUTTON again, and you will hear a beep and the control buttons will start working again.

## 21. DEGAUSS BUTTON

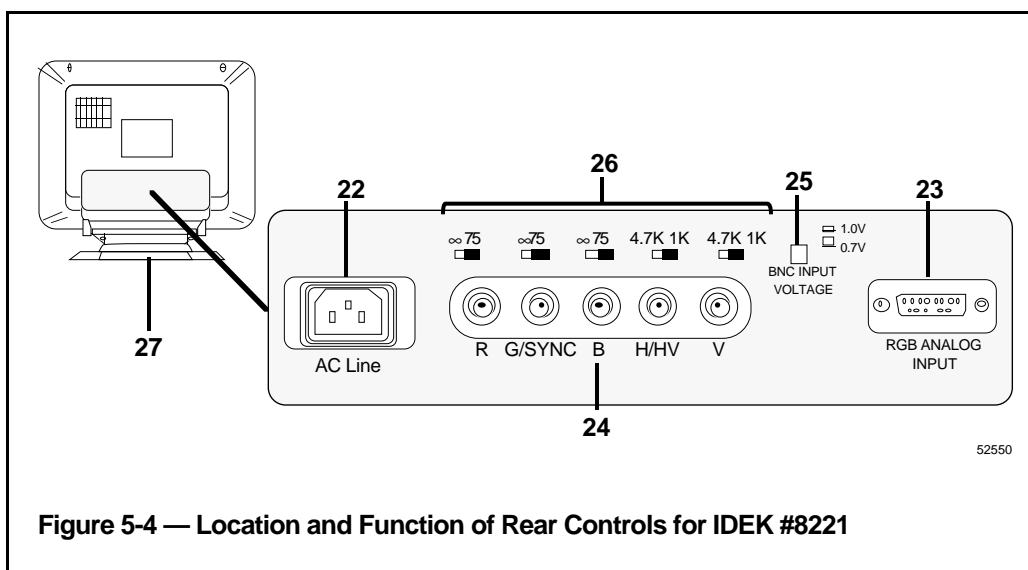
-   
DG
- Use to cancel magnetism when swiveling or moving the monitor causes poor purity.
  - The button operates for approximately 10 seconds and goes off automatically.
- Note: - Degauss occurs automatically on power on and it is best to leave 30 minutes between each degauss operation.

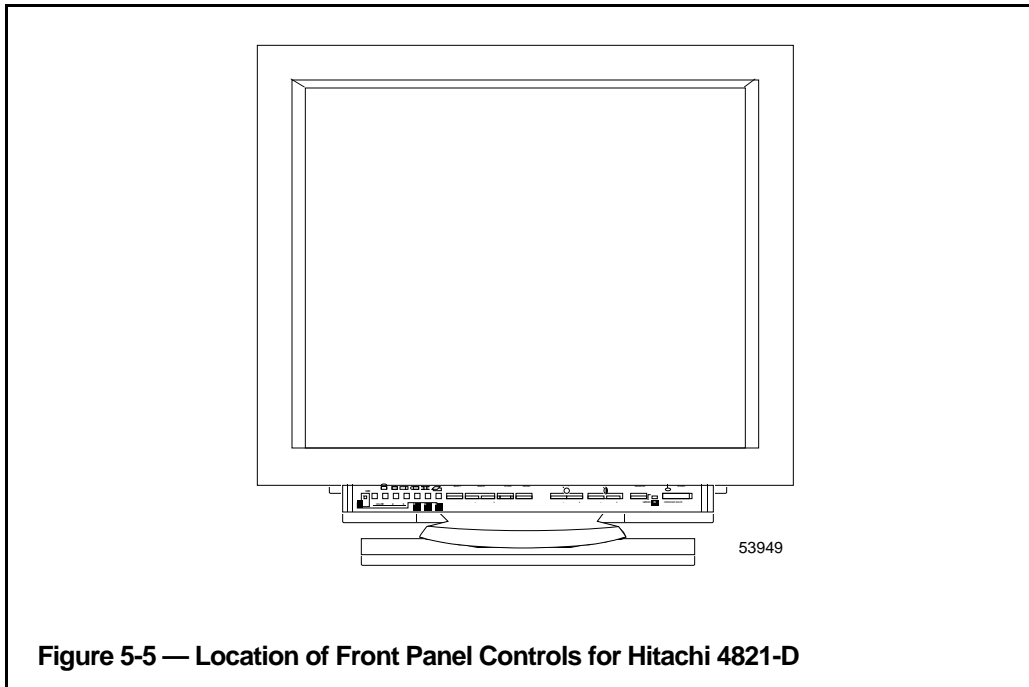

**Figure 5-4 — Location and Function of Rear Controls for IDEK #8221**

22. AC INPUT CONNECTOR
  - Connect to the AC outlet with the supplied AC power cord.
  - Note: - Make sure the POWER SWITCH is turned OFF before connecting the power cord.
23. 15PIN D-SUBSIGNAL INPUT CONNECTOR
  - Allows equipment having analog RGB output to be connected.
24. BNC SIGNAL INPUT CONNECTORS
  - Allows equipment having analog RGB output to be connected.
25. BNC INPUT VOLTAGE SWITCH (.07V/1.0V)
  - Used to select the appropriate BNC video input voltage for your equipment.
  - Set to 0.7V for 0.74 volt peak to peak or 1.0V for 1.0 volt peak to peak.
26. BNC IMPEDANCE SELECT SWITCHES (VIDEO:  $\infty/75\Omega$ , SYNC:  $4.7K\Omega/1K\Omega$ )
  - Select  $75\Omega$  for the line impedance.
  - If the monitor is used in a loop-through operation, set these switches to the left ( $\infty$  for video,  $4.7K\Omega$  for sync). For single unit operation, or when the monitor is the last unit in a loop-through string, set the switches to the right ( $75\Omega$  for video,  $1K\Omega$  for sync). The switches of the unused BNC SIGNAL INPUT CONNECTORS should also be set to the right.
27. TILT-SWIVEL STAND
  - Allows the screen angle to be adjusted by 90 degrees horizontally, 15 degrees up and 5 degrees down.

### 5.4.3 HITACHI Model HM-4821-D

Subsection 5.4.3 describes the operational controls of the Hitachi 21-inch monitor (Model HM-4821-D). The location and basic function of each panel screen control is shown in Figures 5-5, 5-6, and 5-7.



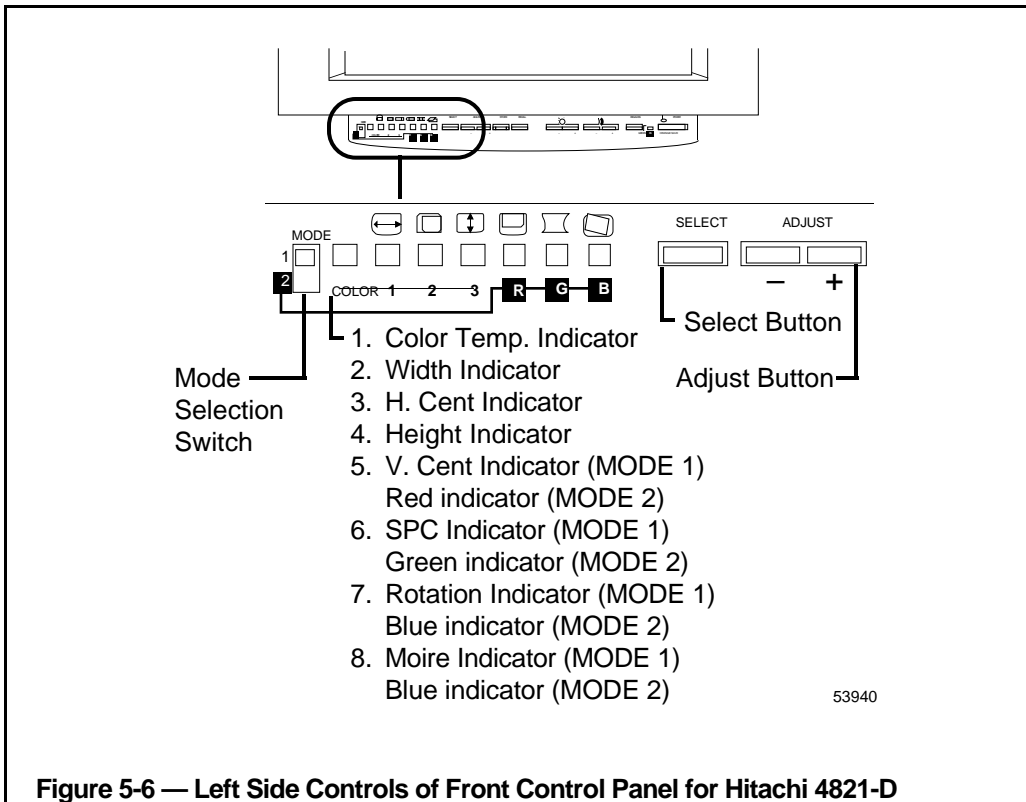

Figure 5-6 — Left Side Controls of Front Control Panel for Hitachi 4821-D

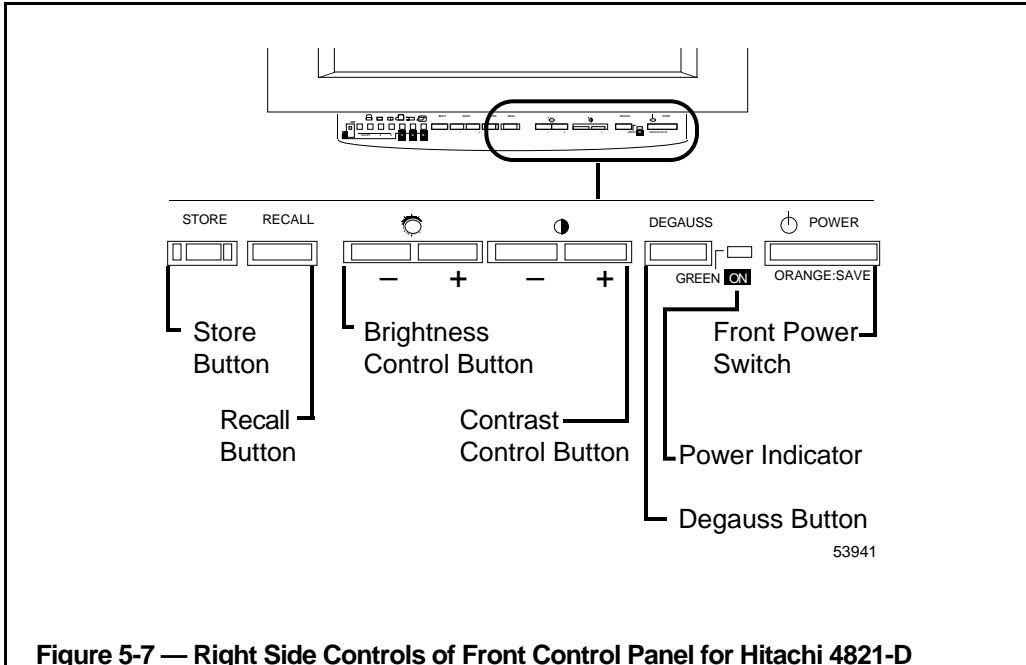

Figure 5-7 — Right Side Controls of Front Control Panel for Hitachi 4821-D

#### 5.4.3.1 Interfacing

**CAUTION**

Connecting the cables incorrectly may cause injury or damage to the monitor. Turn off the power before connecting any cables.

#### INPUT SIGNALS

Connect video signals cables to the corresponding BNC input connectors on the rear panel as shown in Figure 5-4.

#### SYNC SELECTION

Synchronization input is possible for composite sync on green signal, H.V. mixed external sync signal and H.V. separate external sync signal. (Auto selection)

#### REMOTE CONTROL INTERFACE PORT

This port is used only for Factory preset and this is not user accessible.

#### INPUT VOLTAGE

The input voltage range for this equipment will be selected automatically.

**NOTE**

To comply with FCC regulations, a shielded interface cable is recommended.

5.4.3.1 Interfacing (Continued)

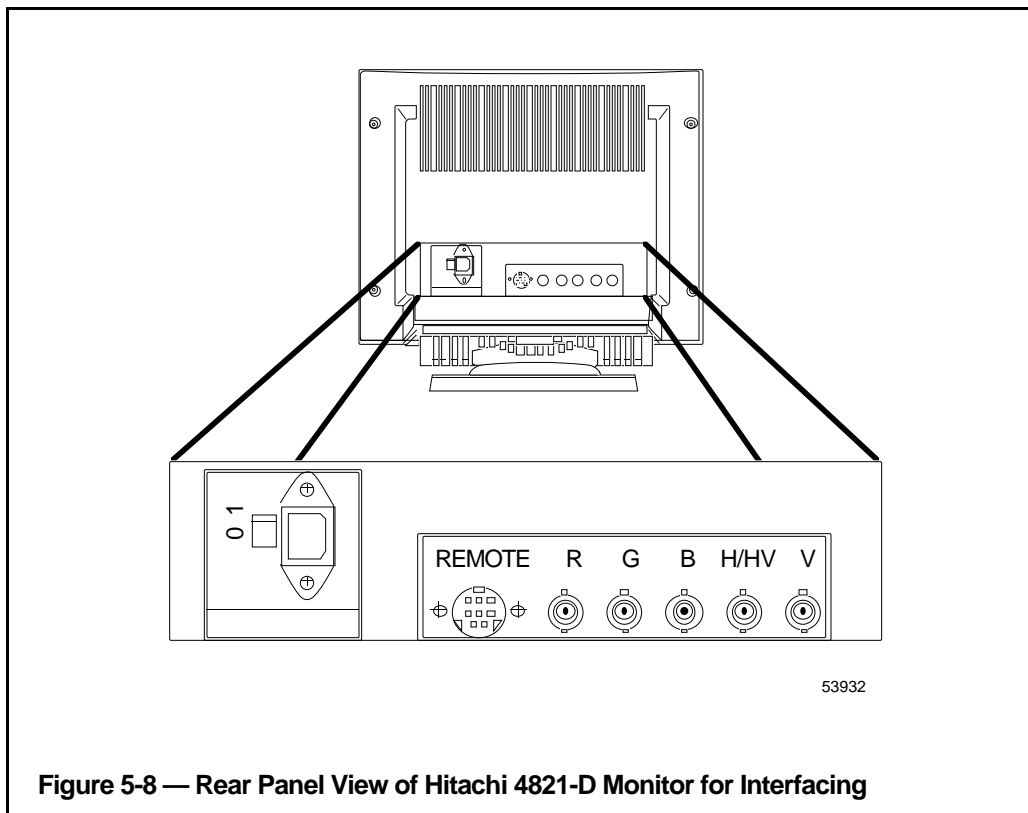

Figure 5-8 — Rear Panel View of Hitachi 4821-D Monitor for Interfacing

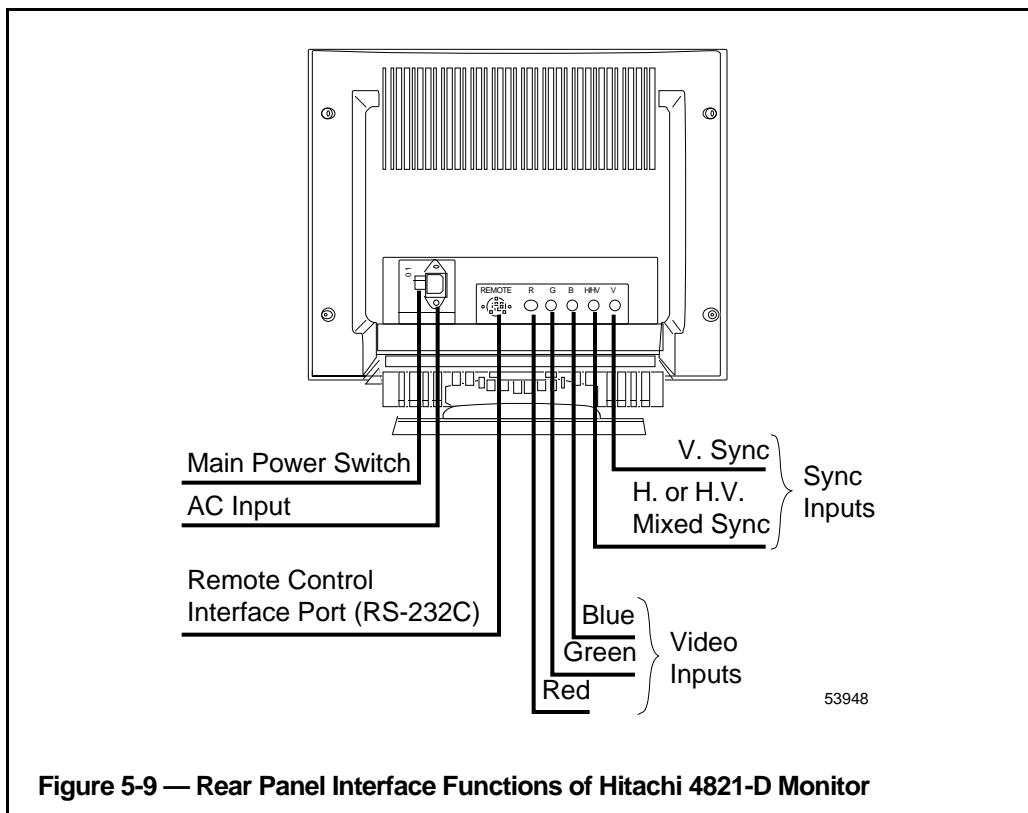

Figure 5-9 — Rear Panel Interface Functions of Hitachi 4821-D Monitor

### 5.4.3.2 Operator Controls

The monitor usually operates in the Operation mode, and the picture is aligned according to the data in the internal memories that correspond to the video signal input.

Press the SELECT button, the monitor enters in the Adjustment mode, and the picture becomes adjustable.

- MAIN SWITCH switch (see Figure 5-4)
  - Turn on the power for the monitor by pressing the MAIN POWER switch to the “ON” position (the “1” side of the switch) on the rear panel.
  - To turn off the main power, press the MAIN POWER switch to the “OFF” position (the “0” side of the switch).

**IMPORTANT**—If you do not use the monitor for a long time, please turn off MAIN POWER switch on rear panel.

- FRONT POWER switch
  - If you want the monitor in Off mode by FRONT POWER switch, while MAIN POWER switch in on, press this switch button. The POWER indicator will turn to green.
  - To change the monitor from Off mode to Operation mode, press the FRONT POWER switch button or turn on/off the MAIN POWER switch.

**NOTE:** If the monitor is in Stand-by mode or Suspend mode, you can not operate the monitor until the input signal status is returned to On Mode 1. Please see next item.

- POWER indicator  
This monitor has power save mode, and POWER indicator lights as follows:

Power Save Mode	Power Indicator	Input Signal Status		
		Horizontal Sync Signal	Vertical Sync Signal	Video Signal
On	Green	In	In	In
Stand-by	Orange	Out	In	Out
Suspend	Orange	In	Out	Out
Off (H.V. loss)	Orange	Out	Out	Out
Off (FRONT POWER switch is Off.)	Orange	All conditions	All conditions	All conditions
Off (MAIN POWER switch is Off.)	Off	Out	Out	Out

- **DEGAUSS button**  
The degauss function is automatically initiated when power is applied. By pressing the DEGAUSS button, the monitor will be manually degaussed.

**NOTE:** Manual degaussing is highly recommended after tilt and swivel operation.

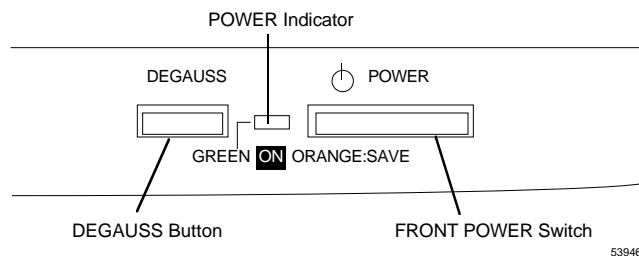

- **CONTRAST control button**  
Refer to DISPLAY SETTING, subsection 5.4.3.3.
- **BRIGHTNESS control button**  
Refer to DISPLAY SETTING, subsection 5.4.3.3.

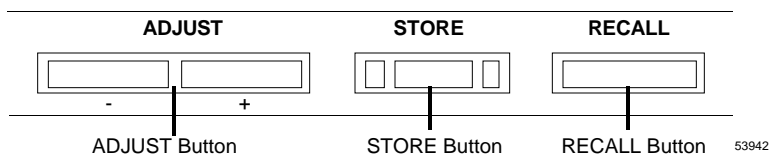

- **RECALL button**  
You can recall the factory adjusted data or initial default data (not user stored data) by pressing the RECALL button more than two seconds. After this, you press the STORE button, the displayed data is stored in the memory. If you want to recall the user stored data, turn on/off the FRONT POWER switch

**NOTE:** If you press the RECALL button, and turn off the MAIN POWER switch before pressing the STORE button and turn on the MAIN POWER switch again, the screen displays the original stored data.  
When the input signal is not a preset timing signal, if you press the STORE button, all the LEDs light up indicating an error.

- **STORE button**  
Press the STORE button after making the adjustments, the adjusted data is stored in memory and the monitor exits from the Adjustment mode.



- **ADJUST button**  
When you press the “+” button in the Adjustment mode of MODE 1 and MODE 2, the screen image changes as follows.

MODE 1 { WIDTH : Horizontal display width becomes wider.  
H. CENT : Display center shifts to the right.  
HEIGHT : Vertical display height becomes taller.  
V. CENT : Display center shifts upward.  
SPC (side pinchusion) : Vertical edges barrel out.  
ROTATION : Display rotates clockwise. (Only available for HM-4821-D)  
MOIRE : Moire pattern is changed.  
COLOR Temperature : Color temperature changes to operator adjusted color temperature.

MODE 2 { R : Red of Color temperature No. 3 becomes strong.  
G : Green of Color temperature No. 3 becomes strong.  
B : Blue of Color temperature No. 3 becomes strong.

When you press the “-” button in the Adjustment mode, the screen image changes as follows.

MODE 1 { WIDTH : Horizontal display width becomes narrower.  
H. CENT : Display center shifts to the left.  
HEIGHT : Vertical display height becomes shorter.  
V. CENT : Display center shifts downward.  
SPC (side pinchusion) : Vertical edges barrel in.  
ROTATION : Display rotates counterclockwise. (Only available for HM-4821-D)  
MOIRE : Moire pattern is changed.  
COLOR Temperature : Color temperature changes to color temperature No. 1.

MODE 2 { R : Red of Color temperature No. 3 becomes weak.  
G : Green of Color temperature No. 3 becomes weak.  
B : Blue of Color temperature No. 3 becomes weak.

**NOTE:** When you adjust MOIRE, moire pattern may be reduced. (It depends on the preset timing.)

If you compensate MOIRE excessively, horizontal jitter may appear on the picture. (It depends on timing.)

When you adjust MOIRE, adjust so horizontal jitter does not appear on the picture.

- **SELECT button**  
By pressing the SELECT button, the monitor enters into two “Adjustment” MODEs by selecting the mode selection switch.

MODE 1      The WIDTH indicator lights up and you can adjust the WIDTH.

MODE 2      The **R** indicator lights up and you can adjust red of Color Temperature No. 3.

Pressing the SELECT button will cause the indicator light to shift right, enabling the adjustment feature for that indicator to become active.

If you press the SELECT button in MODE 1 when the ROTATION indicator lights up, the COLOR indicator lights.

If you press the SELECT button in MODE 2 when the **B** indicator was light, the **R** indicator lights.

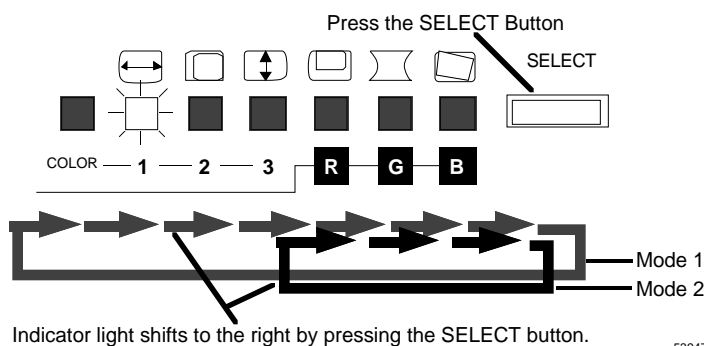

- **MODE selection switch**  
You can select the Adjustment MODE 1 or MODE 2.  
When you select MODE 1, you can adjust (select) the following setting:
  - Horizontal Width,
  - Horizontal Centering
  - Vertical Height
  - Vertical Centering
  - SPC
  - Rotation (Only available for HM-4821-D)
  - Moire
  - Color Temperature

When you select MODE 2, you can adjust the Color Temperature No. 3.

- Red of Color Temperature No. 3
- Green of Color Temperature No. 3
- Blue of Color Temperature No. 3

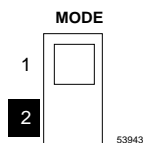

- **COLOR Temperature indicator**  
See DISPLAY SETTING, subsection 5.4.3.3.
- **WIDTH indicator**  
The WIDTH indicator lights up, when you select WIDTH in MODE 1.

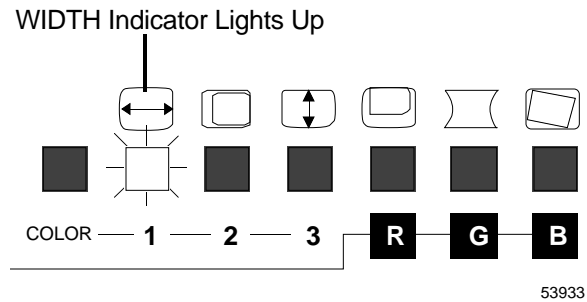

- **H. CENT indicator**  
The H. CENT indicator lights up, when you select the H. CENT in selecting MODE 1.

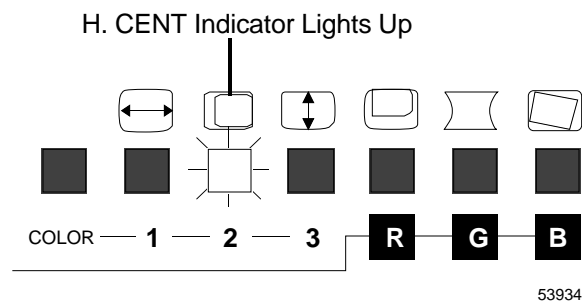

- **HEIGHT indicator**  
The HEIGHT indicator lights up, when you select HEIGHT in MODE 1.

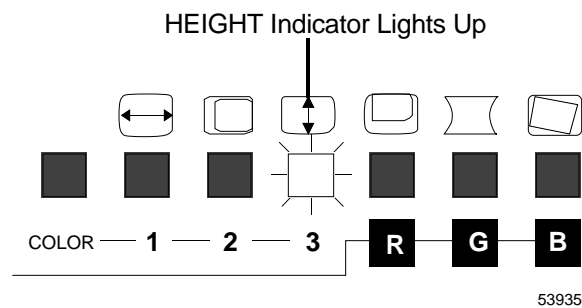

- V. CENT indicator (MODE 1)  
RED indicator (MODE 2)
  - The V. CENT indicator lights up, when you select V. CENT in MODE 1.
  - The RED indicator lights up, when you select RED in MODE 2.

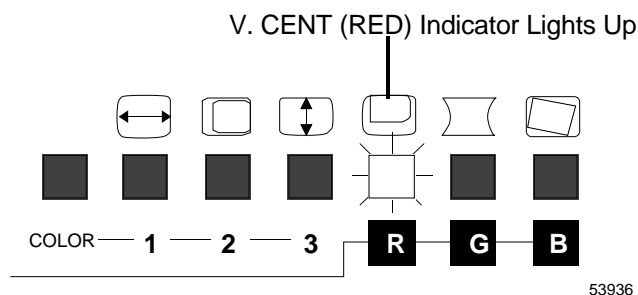

- SPC indicator (MODE 1)  
GREEN indicator (MODE 2)
  - The SPC indicator lights up, when you select SPC in MODE 1.
  - The GREEN indicator lights up, when you select GREEN in MODE 2.

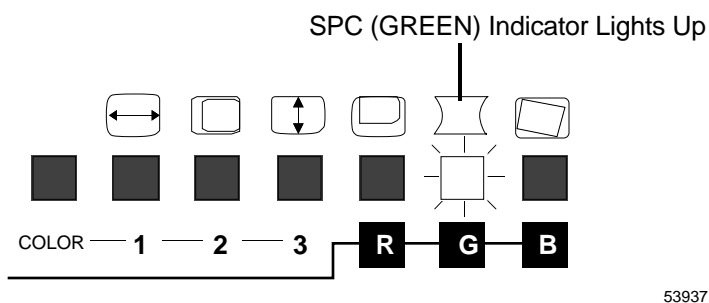

- ROTATION indicator (MODE 1) (Only available for HM-4821-D)  
BLUE indicator (MODE 2)
  - The ROTATION indicator lights up, when you select ROTATION in MODE 1.
  - The BLUE indicator lights up, when you select BLUE in MODE 2.

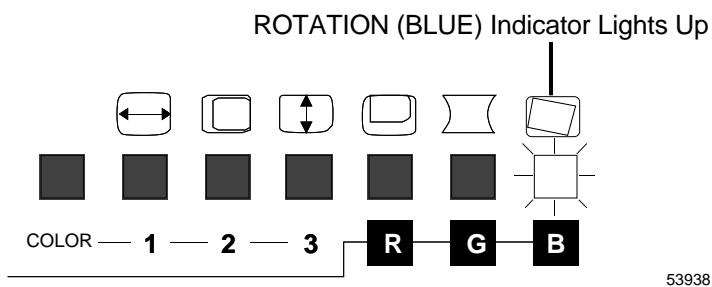

- MOIRE indicator (MODE 1) (Only available for HM-4820-D)  
BLUE indicator (MODE 2)
  - The MOIRE indicator lights up, when you select MOIRE in MODE 1.
  - The MOIRE indicator lights up, when you select BLUE in MODE 2.

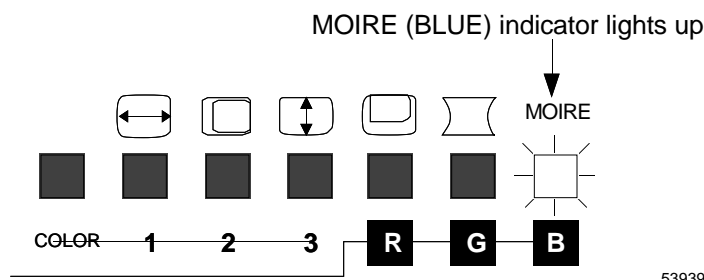

### 5.4.3.3 Display Setting

You can adjust the following settings by using the screen control buttons on the front panel:

- |                           |   |
|---------------------------|---|
| (1) Contrast              | (8) Rotation (Only available for HM-4821-D)           |
| (2) Brightness            | (9) Moire: HM-4821-D...Option<br>HM-4820-D...Standard |
| (3) Horizontal Width      | (10) Color Temperature selection                      |
| (4) Horizontal Centering  | (11) RGB Color Balance                                |
| (5) Vertical Height       |   |
| (6) Vertical Centering    |   |
| (7) SPC (Side Pincushion) |   |

#### (1) Contrast

The contrast control adjusts the contrast of the screen image.

- Press the “+” button, the screen increases the contrast between light and dark.
  - Press the “-” button, the screen decreases the contrast between light and dark.
- When you press “+” button and “-” button at the same time, Contrast value becomes maximum.

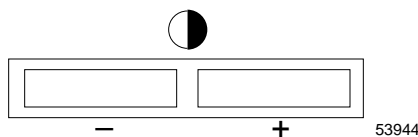

#### (2) Brightness

The brightness control adjusts the brightness of the screen.

- Press the “+” button, the screen increases brightness.
  - Press the “-” button, the screen decreases brightness.
- When you press “+” button and “-” button at the same time, Brightness value becomes maximum.

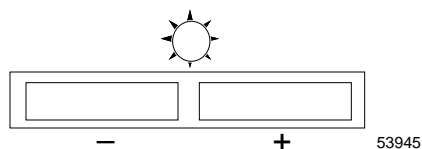

**NOTE:** If you want to keep the adjusted contrast and brightness settings for the next time you turn on the monitor, store the adjusted data by pressing the STORE button before you turn off the monitor.

(3) Horizontal Width Setting

1. Select MODE 1 by the mode selection switch, and press the SELECT button until the WIDTH indicator lights up.

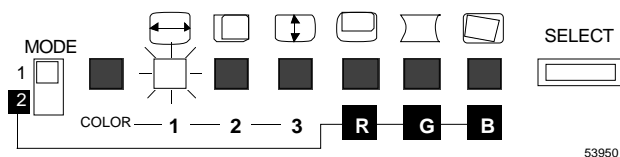

2. Adjust the horizontal width by pressing the ADJUST button (+) or (-).

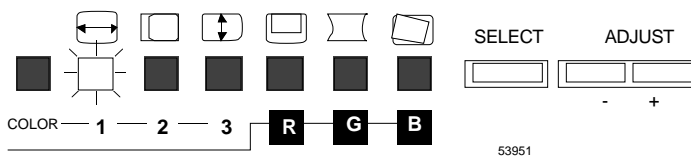

3. After adjusting the horizontal width, if you want to:
  - Store the adjusted data, press the STORE button.

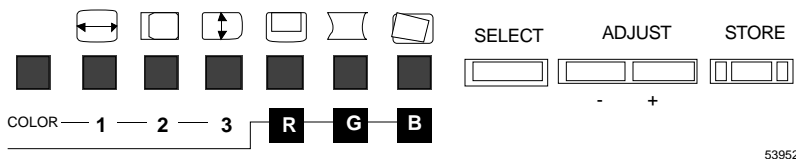

- Continue adjustment, press the SELECT button.

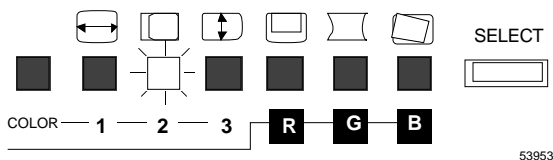

(4) Horizontal Centering Setting

1. Select MODE 1 by the mode selection switch, and press the SELECT button until the H. CENT indicator lights up.

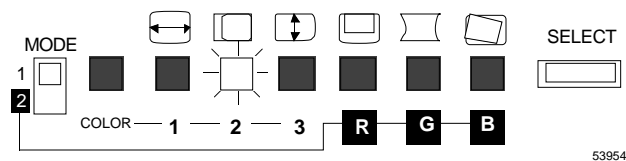

- Adjust the horizontal centering by pressing the ADJUST button (+) or (-).

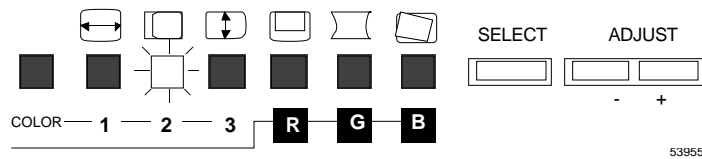

- After adjusting the horizontal width, if you want to:
  - Store the adjusted data, press the STORE button.

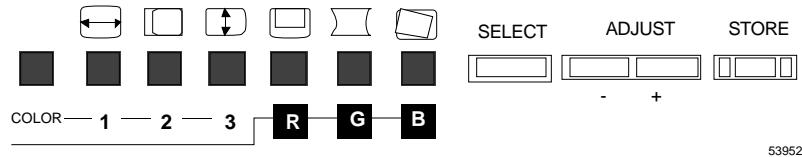

- Continue adjustment, press the SELECT button.

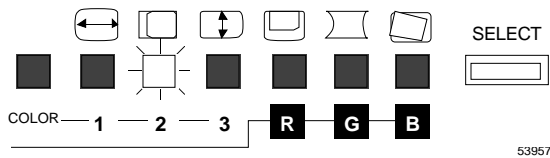

(5) Vertical Height Setting

- Select MODE 1 by the mode selection switch, and press the SELECT button until the HEIGHT indicator lights up.

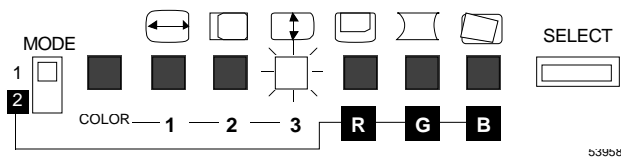

- Adjust the vertical height by pressing the ADJUST button (+) or (-).

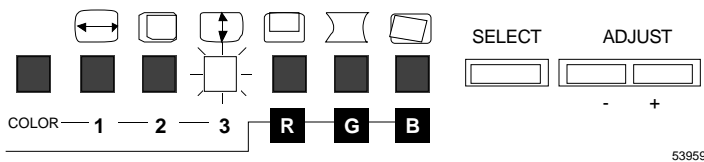

3. After adjusting the vertical height, if you want to:
  - Store the adjusted data, press the STORE button.

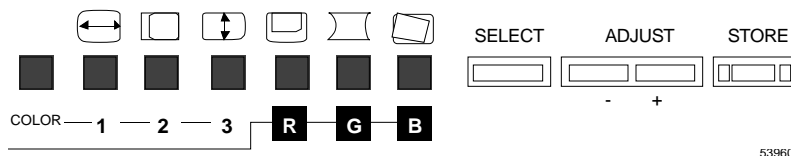

- Continue adjustment, press the SELECT button.

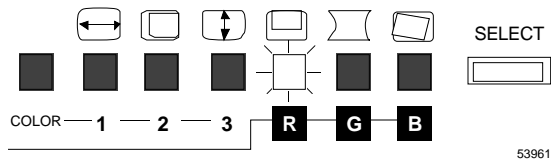

(6) Vertical Centering Setting

1. Select MODE 1 by the mode selection switch, and press the SELECT button until the V. CENT indicator lights up.

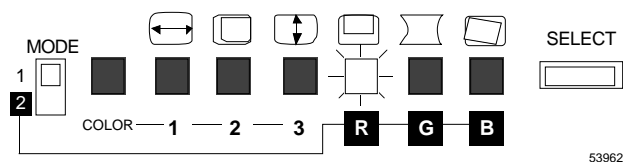

2. Adjust the vertical centering by pressing the ADJUST button (+) or (-).

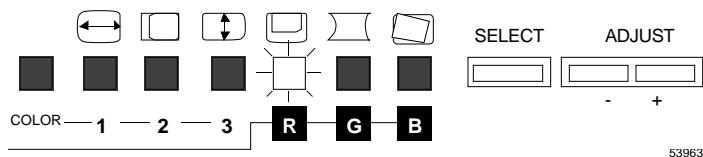

3. After adjusting the vertical centering, if you want to:
  - Store the adjusted data, press the STORE button.

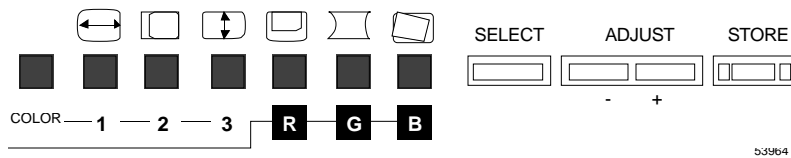



- Continue adjustment, press the SELECT button.

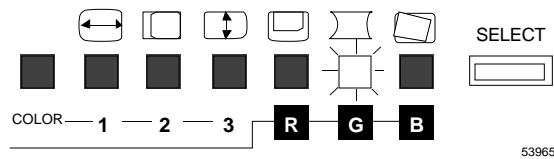

(7) SPC Setting

1. Select MODE 1 by the mode selection switch, and press the SELECT button until the SPC indicator lights up.

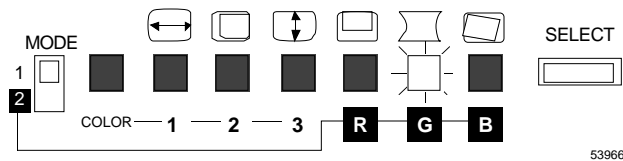

2. Adjust the side pincushion by pressing the ADJUST button (+) or (-).

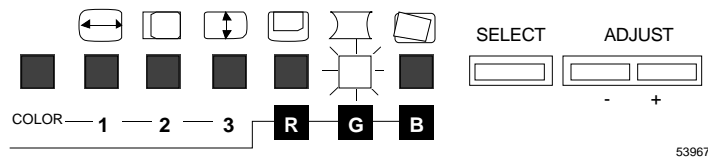

3. After adjusting the side pincushion, if you want to:
  - Store the adjusted data, press the STORE button.

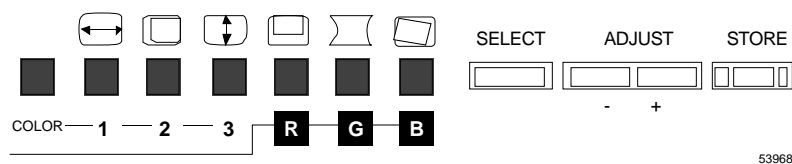

- Continue adjustment, press the SELECT button.

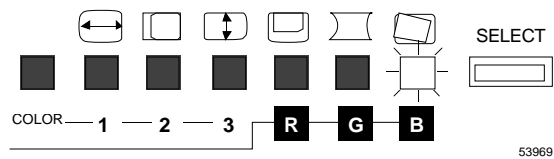

(8) Rotation Setting (Only available for HM-4821-D)

1. Select MODE 1 by the mode selection switch, and press the SELECT button until the ROTATION indicator lights up.

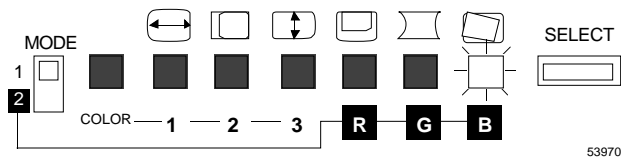

2. Adjust the rotation by pressing the ADJUST button (+) or (-).

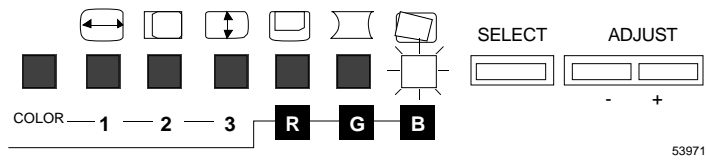

3. After adjusting the rotation, if you want to:
  - Store the adjusted data, press the STORE button.

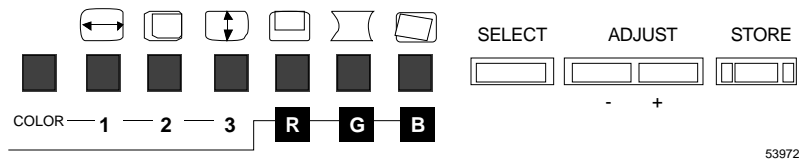

- Continue other adjustment by pressing the SELECT button.

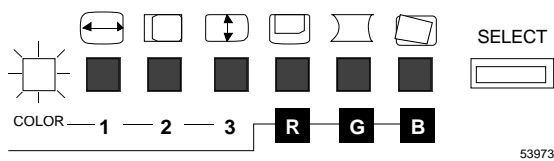

## (9) Moire Setting (Only available for HM-4820-D)

1. Select MODE 1 by the mode selection switch, and press the SELECT button until the MOIRE indicator lights up.

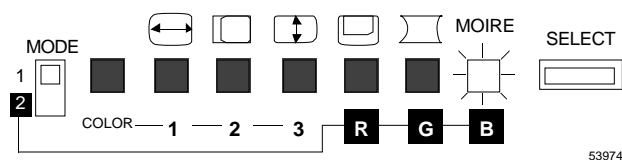

2. Adjust the moire by pressing the ADJUST button (+) or (-).

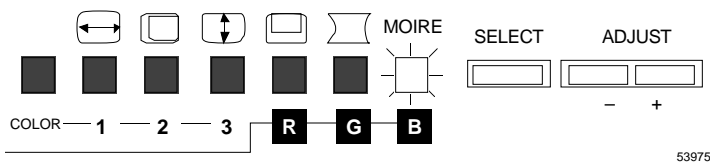

3. After adjusting the moire, if you want to:
  - Store the adjusted data, press the STORE button.

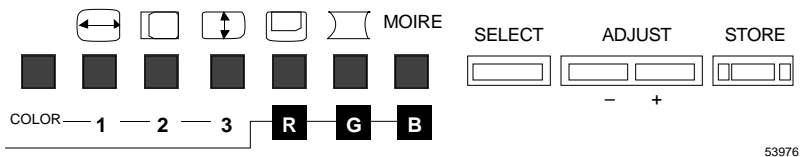

- Continue other adjustment by pressing the SELECT button.

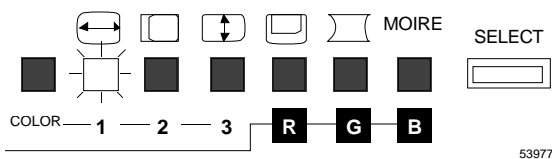

## (10) Color Temperature Setting

Following three types of color temperature have been stored prior to shipping, and these are selectable from the front panel.

- 1 655K + 7MPCD
- 2 9300K + 8MPCD
- 3 User adjustable (default 9300K + 8MPCD)

(This color temperature is adjustable in MODE 2 of RGB Color Balance. See display setting item number 11)

1. Press the SELECT button until COLOR indicator lights up. The **2** indicator lights up as a default. It shows the color temperature of 9300K + 8MPCD.

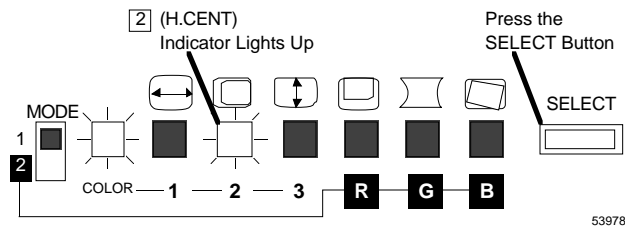

2. To change the color temperature to 6550K + 8MPCD, press the ADJUST (-) button, the **3** indicator lights up.

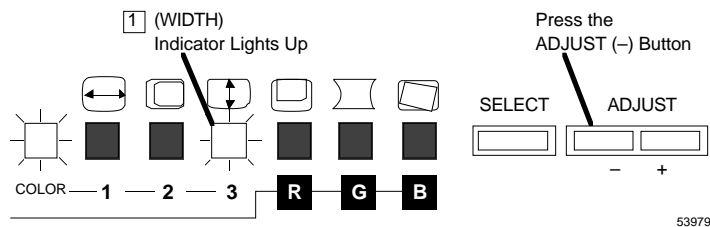

3. To change the color temperature to adjusted color temperature by MODE 2, press the ADJUST (+) button, the **3** indicator lights up.

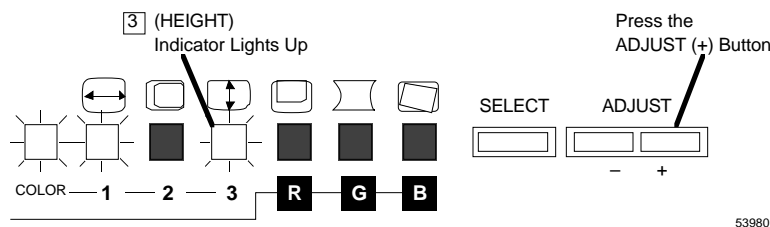

4. After selection of color temperature, store the selected data by pressing the STORE button or

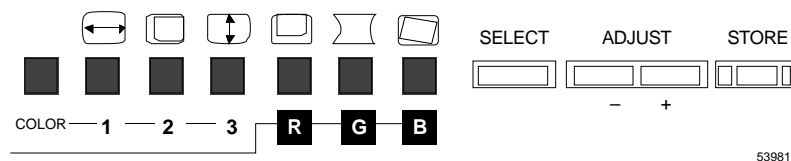

- Continue adjustment by pressing the SELECT button.

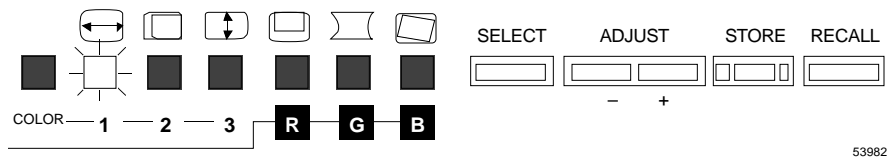

When the COLOR indicator lights up, one of the three indicators (WIDTH, H. CENT, and HEIGHT) lights up. If you press the ADJUST (+) button, indicator light shifts to the right. If you press the ADJUST (-) button, indicator light shifts to the left.

(11) RGB Color Balance Adjustment

A. Red of color balance 9300K + 8MPCD Setting

1. Select MODE 2 by the mode selection switch, and press the SELECT button until the **R** indicator lights up.

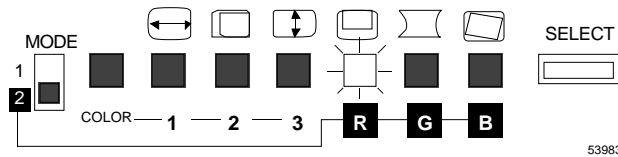

2. Adjust the red of color balance 9300K + 8MPCD by pressing the ADJUST button (+) or (-).

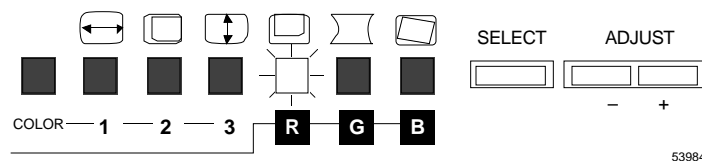

3. After adjusting the red of color balance 9300K + 8MPCD, if you want to:
  - Store the adjusted data, press the STORE button.

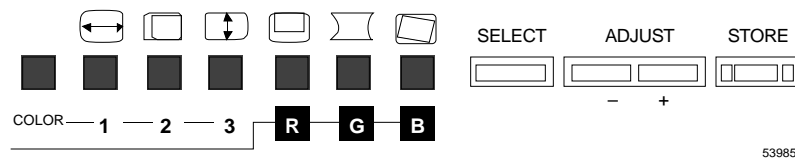

- Continue adjustment by pressing the SELECT button.

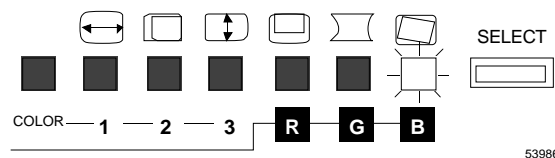

B. Green of color balance 9300K + 8MPCD Setting

1. Select MODE 2 by the mode selection switch, and press the SELECT button until the **G** indicator lights up.

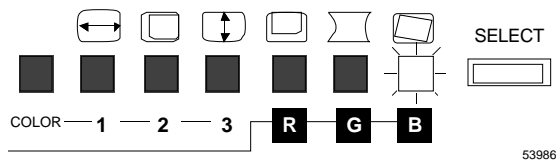

2. Adjust the green of color balance 9300K + 8 MPCD by pressing the ADJUST button (+) or (-).

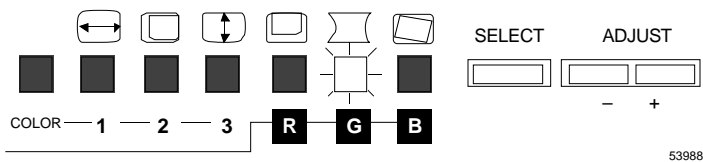

3. After adjusting the green of color balance 9300K + 8MPCD, if you want to:
  - Store the adjusted data, press the STORE button.

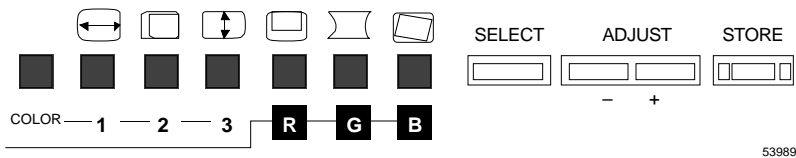

- Continue adjustment by pressing the SELECT button.

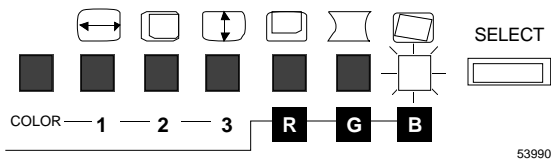

C. Blue of color balance 9300K + 8MPCD Setting

1. Select MODE 2 by the mode selection switch, and press the SELECT button until the **B** indicator lights up.

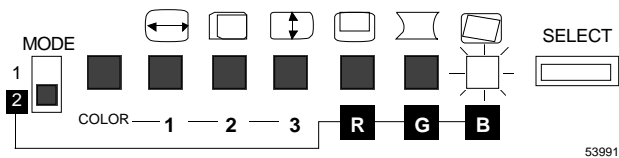

2. Adjust the blue of color balance 9300K + 8 MPCD by pressing the ADJUST button (+) or (-).

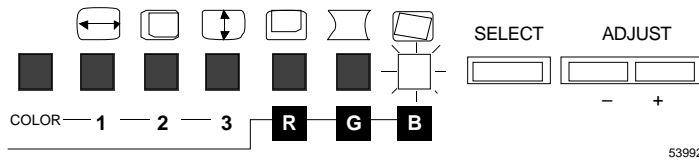

3. After adjusting the blue of color balance 9300K + 8MPCD, if you want to:
  - Store the adjusted data, press the STORE button.

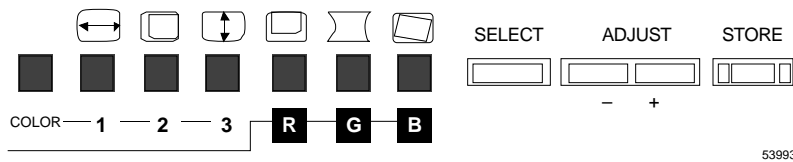

- Continue adjustment by pressing the SELECT button.

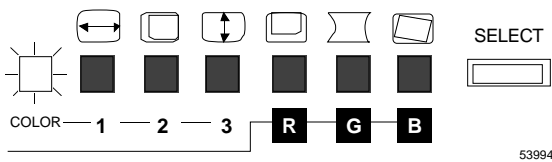

**NOTE:** Factory preset data of RGB color balance is set to maximum value. For this reason, when you adjust balance the first time or after you press the RECALL button, if you press the “+” button, the RGB color balance is not changed.





**SERVICE  
Section 6**

*This section presents service instructions unique to the Enhanced Micro TDC 3000 Control System.*

**6.1 OVERVIEW**

The multinode module used in the Enhanced Micro TDC 3000 Control System is similar in appearance to other LCN-type, 10-slot modules. However, it uses a different backplane and power supply. It also can only accept certain PWB boards (generally, the newer, more compact board designs) because of limited space for each node. For service information on this module and the printed circuit boards contained in it, refer to the *8-Node Multinode Module Service* manual in the *Implementation/8-Node Enhanced Micro TDC 3000* binder.

The cartridge drives and history module used in this system are the same or similar to those used in the Universal Station (US) except for physical mounting arrangements. The hard drive (part of the history module in tower #2) is powered by a power supply in the bottom of the tower. For service information on these peripherals, refer to *Universal Station Service* in the *LCN Service - 1* binder.

The Enhanced Micro TDC 3000 towers contain an air filter located just above the Multinode Module. Figure 6-1 shows the location of the scotfoam air filter. Subsection 6.3 contains information on how to gain access to the air filter.

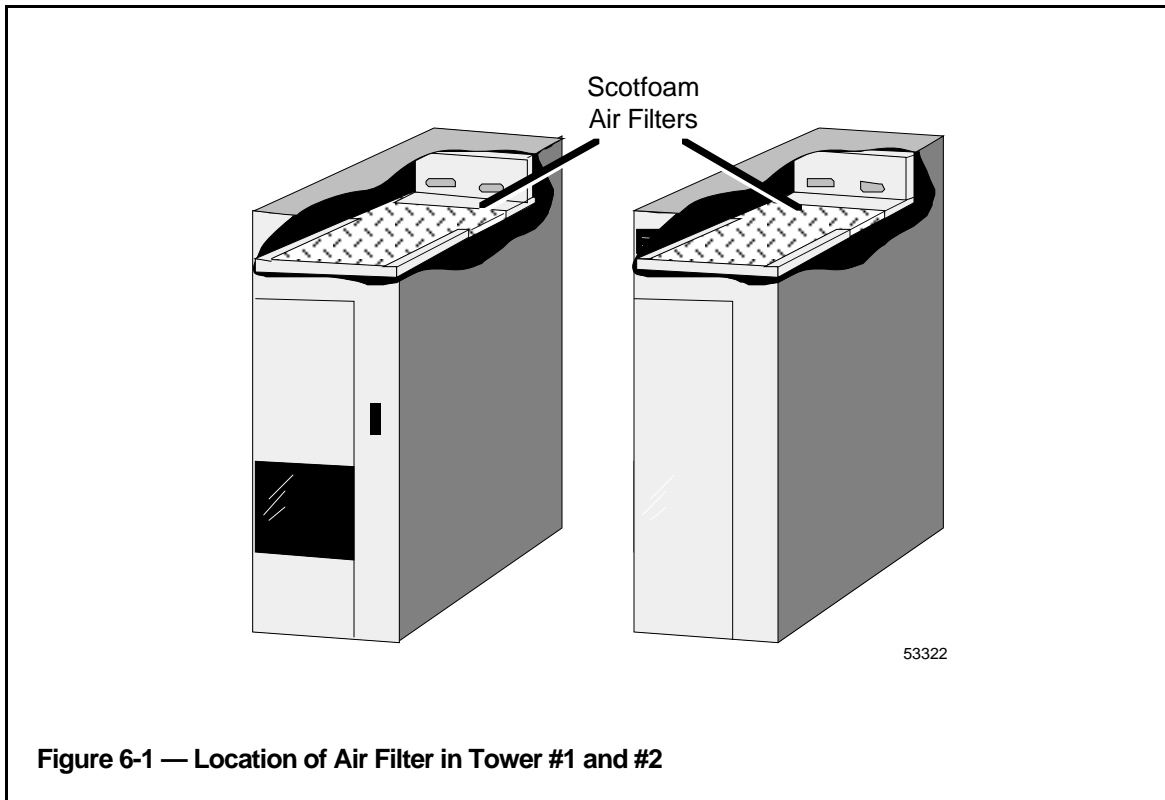

**Figure 6-1 — Location of Air Filter in Tower #1 and #2**

Table 6-1 gives a summary of a recommended inspection schedule for different operating environments. Maintenance is performed by removing, cleaning (by hand-washing) and reinstalling the air filter. If the air filter has been cleaned numerous times, total replacement may be necessary. It can be ordered through logistics using part number 51201201-600.

**Table 6-1 — Recommended Periodic Inspection and Cleaning of Air Filters**

Equipment Operating Environment	Frequency of Inspection and Cleaning
Harsh	30 Days
Heavy	60 Days
Moderate	90 Days
Office	6 Months

Table 6-1 lists node types which can be installed in the Enhanced Micro TDC 3000 Control System. In addition, the table lists the factory-assigned node numbers and the board slots where those node types are found. For details about specific boards used in each option, consult the *8-Node Multinode Module Service* manual in the *Implementation/8-Node Enhanced Micro TDC 3000* binder.

**Table 6-2 — Enhanced Micro TDC 3000 Node Numbers and Node Types**

LCN NO.	UCN NO.	NODE TYPES	TOWER	BOARD SLOTS
5	1	AM—Application Module	#1*	7, 8
1		US—Universal Station	#1	1, 2
3		NIM—Network Interface Module	#1	9,10
6		HM—History Module	#2*	7,8
2		US—Second Universal Station	#2	1, 2
7		US—Third Universal Station (optional)	#1, 2	4, 5
8		US—Fourth Universal Station (optional)	#1	4, 5
4	2	NIM—Redundant NIM (optional)	#2	9,10
7		CG—Computer Gateway (optional)	#2	4, 5
10		NG—Network Gateway (single cable)		
11		NG—Network Gateway (dual cable)		
12		PLCG—Programmable Logic Controller Gateway (optional)	#1, 2	4, 5
13		EPLCG—Enhanced Programmable Logic Controller Gateway (optional)		
14		PNM—Plant Network Module		
	3	APMM—Adv. Proc. Mgr Mod. (Primary)		
	4	APMM—Adv. Proc. Mgr Mod. (optional Secondary)		

\* Right Tower is #1 and Left Tower is #2

The touchscreen, trackball, keyboards, hard drive/power supply, cartridge drive, printer, printer-head, printer ribbon, and air filters are ORU (Optimum Replaceable Unit) items and are replaced when found faulty. Refer to the spare parts list in subsection 6.5 and to the *Universal Station Service* in the *LCN Service - 1* binder for their order numbers.

Multinode Module parts which include the 3/3/2/2 cardcage, power supply, fan assembly, and circuit cards are also replaced at the ORU level. For these parts, refer to the spare parts section in the *8-Node Multinode Module Service* manual in the *Implementation/8-Node Enhanced Micro TDC 3000* binder.

Although cables and power cords are not considered ORU items, their part numbers are listed in the spare parts section for reference.

## 6.2 FIELD ADJUSTMENTS

There are no field adjustments for the Enhanced Micro TDC 3000 Control System other than those for the 21" color monitor. When replacing a board, you may have to change some pins (or jumpers) on the board to make the board correspond with the counterpart it is replacing. Do not alter pinning on a board revision socket—the revision number might have changed on the newer board.

The EPDGP-I/O board has pinning options to set the default background shade for the CRT if a palette has not been set in a schematic. You may find additional information on the Set Palette command in the *Picture Editor Reference Manual* in the *Implementation/Engineering Operations - 2* binder. The EPDGP also has a configuration option that is set for either the Engineer's Keyboard or the Supervisor's Keyboard. (If both keyboards are installed, the EPDGP is set up for the Supervisor's Keyboard and the Engineer's Keyboard is connected into the Supervisor's Keyboard.)

### 6.2.1 LCN Node Addressing (Pinning)

Each K2LCN board (slots 1, 4, 7, and 9) has an LCN node address header that must be set for the particular node address it occupies. If you replace one of these boards, be sure the node address jumpers (or switches) on the header are set the same as they were on the board you are replacing. See Figure 6-2 for the location of the K2LCN node header and the pinning options for the K2LCN.

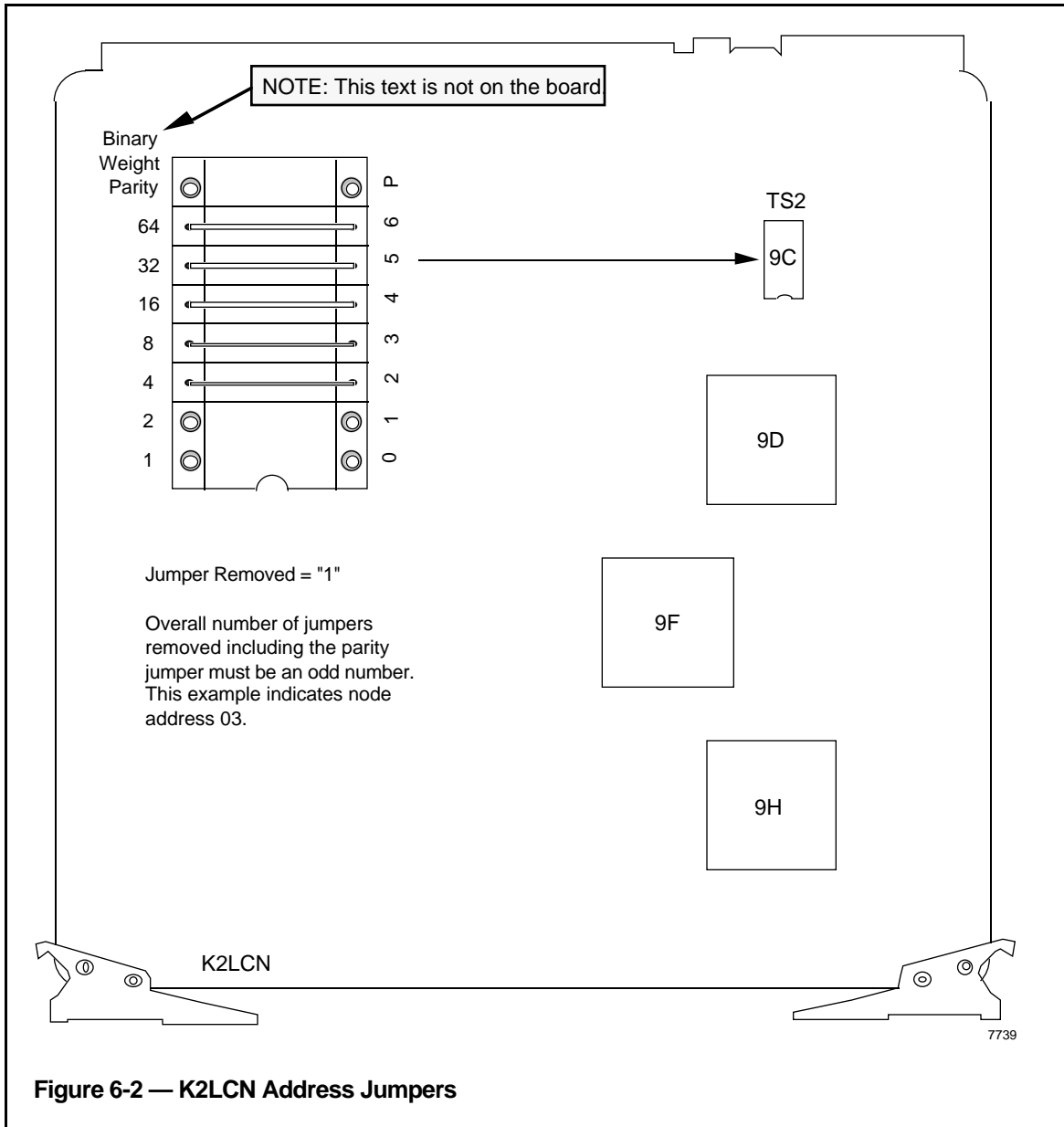
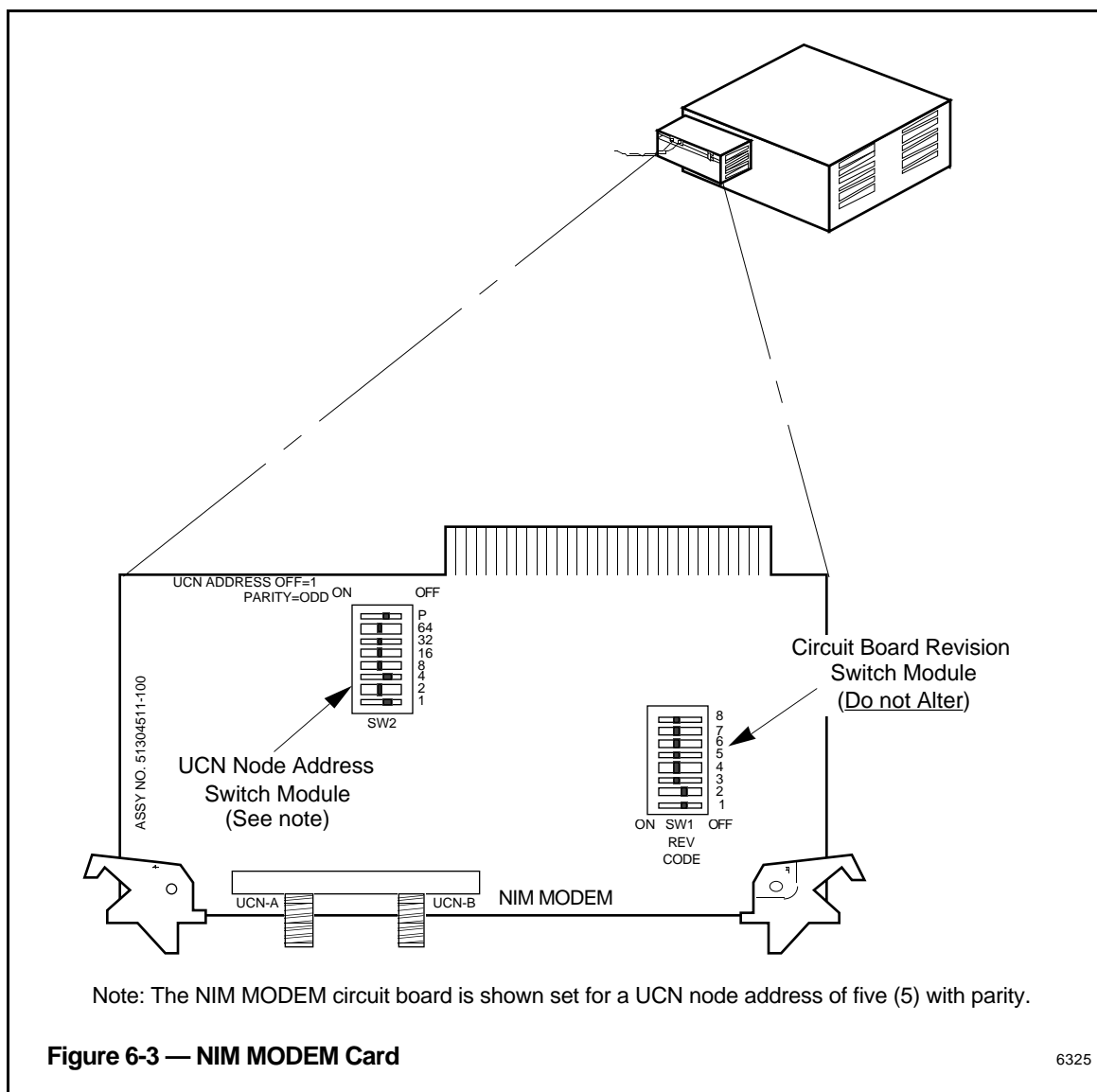

Figure 6-2 — K2LCN Address Jumpers

## 6.2.2 UCN Node Addressing (Pinning)

The NIM MODEM card (slot 10 in tower #1, for the optional redundant NIM slot 10 in tower #2) also has a UCN node address header that must be set for the address it occupies. If you replace this card, the node address switches must be set the same as the card that was removed. See Figure 6-3 for the location of the UCN node header.

The UCN pinning headers are set in the same way as the LCN headers, except there is a larger address range. Acceptable UCN addresses on the Enhanced Micro TDC 3000 control system, however, are “1” for the primary NIM and “2” for the redundant NIM. To set the UCN address, set switches to represent the weights in the node address (a switch “OFF” is a “1”). Adjust parity so that the number of switches set to “OFF”, including the parity switch, is an odd number.



### 6.2.2.1 NIM Modem Card–EMC Directive

The NIM Modem card already has two F-type coaxial connectors connected to chassis ground. The EMC Directive added a face plate as shown in Figure 6-4. The F-type connectors are bolted to the face plate to reinforce the chassis ground. Two LEDs and a test jack are visible and accessible through the face plate.

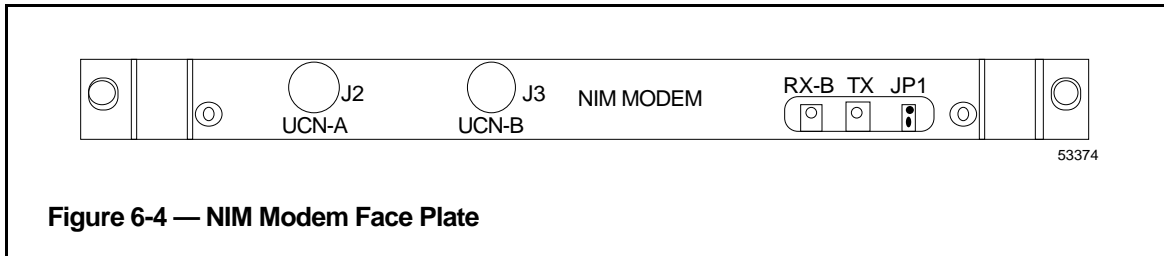

Figure 6-4 — NIM Modem Face Plate

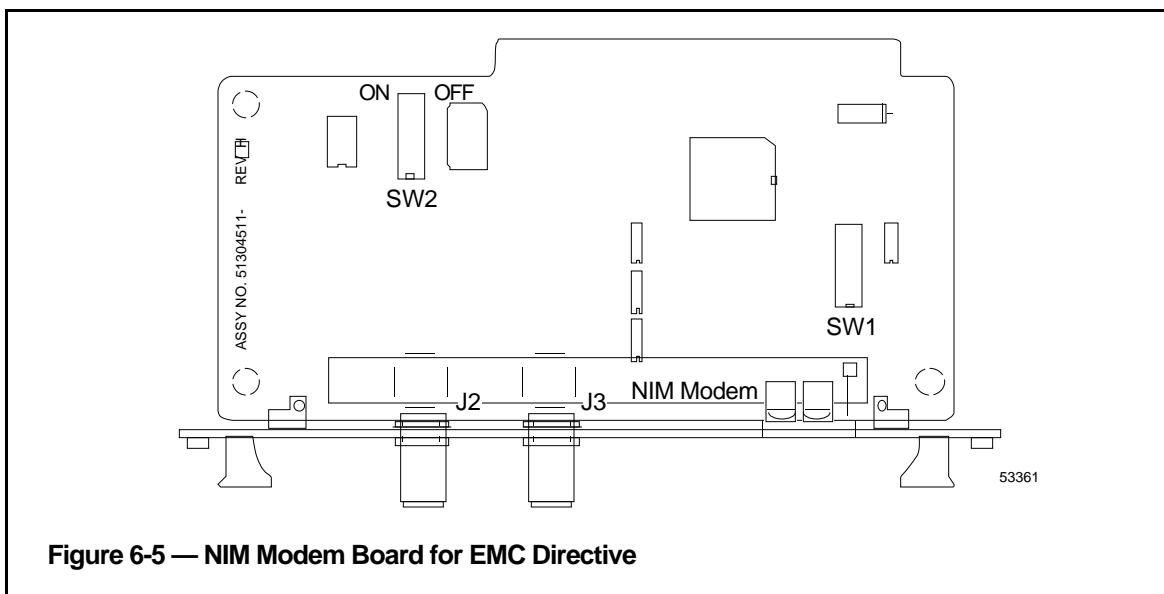

Figure 6-5 — NIM Modem Board for EMC Directive

### 6.2.3 21-Inch Monitor Adjustments

The analog, rotary-type screen control knob adjustments for the IDEK 21-inch Multiscan color monitor are located on the front, just below the screen. The digital, push-button screen control adjustments for the IDEK 21-inch Vision Master color monitor are located inside a recessed, sliding tray (drawer) located below the screen. These adjustments are summarized in Table 6-2.

**Table 6-3 — 21-inch Monitor Adjustments**

CONTROL	ADJUSTMENT
Brightness	Turn knob or press button to adjust the brightness of the display
Contrast	Turn knob or press button to adjust the contrast of the display
Raster rotation	Turn knob or press button to correct the raster tilt of the display
Pincushion correction	Turn knob or press button to correct both the right and left side distortion of the display
Vertical size	Turn knob or press button to adjust the vertical size of the display
Vertical position	Turn knob or press button to adjust the center of the display vertically
Horizontal size	Turn knob or press button to adjust the horizontal size of the display
Horizontal position	Turn knob or press button to adjust the center of the display horizontally
Signal select switch (three-position switch)	VGA: Select VGA when using a VGA graphics card MACII: Select MACII when using an Apple Macintosh or PGC graphics card. OTHER: Select OTHER when using any other graphics card or generator than the above, with a horizontal frequency between 30 and 80 khz. For the UWS, place this switch in the <b>MACII</b> position.
Degauss	Press this button to degauss the CRT



## 6.3 CLEANING

The monitor screen, printer, keyboard, and the cartridge drive heads must be periodically cleaned. For cleaning intervals and instructions, refer to *Universal Station Service* in the *LCN Service - 1* binder.

### 6.3.1 Air Filter Removal and Cleaning

1. Periodically inspect the air filters in each tower for dust buildup—perhaps as frequent as every month all the way up to an annual basis. Refer to Figure 6-1 for the location of the filter(s) and Table 6-1 for a recommended inspection timetable.
2. Each filter is located just above the Multinode Module in a tower, and is accessed by removing the front cover of the tower. Visually inspect the top of the filter for dust buildup. You can see the top of the filter behind the cartridge drives or hard drive.
3. If the filter must be cleaned or replaced, first shut-down the process, then assure power is completely removed from the tower by shutting the power switch OFF on the front of the tower, **then by disconnecting the line cord to the tower**. This is necessary because some electrical components in the tower may not be controlled by the power switch.
4. Remove the two hex-screws which hold the drive support shelf (for either cartridge drives or hard III drive) in place over the filter. Carefully lift the drive support shelf up (not out) with one hand while extracting the filter with the other. Temporarily lay the drive support shelf back in place while you clean or replace the filter.
5. The filter may be cleaned by hand-washing it in a mild detergent, then rinsing it thoroughly in clean water. Be sure the filter is thoroughly dry before attempting to replace it.
6. You may also discard and replace the filter if you wish. Always replace a filter that is torn or so old that parts of it are flaking off.
7. To replace the filter, lift the drive support shelf with one hand using care not to stretch or damage the wiring to the back of the drive(s). Slip the replacement filter in place with the other hand, making sure it lays flat on the Multinode Module.
8. Fasten the drive support shelf in place, using the hex-screws you removed.

## 6.4 TROUBLESHOOTING

Before investigating deeply into a problem, make some preliminary checks:

- Is power applied to both towers and all peripherals? Check power indicators on all devices in the system. Check switches, fuses, and circuit breakers on all equipment to insure they are functioning.

- Note that the front (large) boards can be accessed through the front of each tower by removing the front cover. Remove it by grasping the edges of the panel near the bottom and pulling straight out. With the front cover removed, inspect the confidence indicators on each node's processor (see Figure 3-1). Check the power supply and fan confidence indicators. To replace the cover, slip it under the top front edge and snap it into the two bottom spring catches.
- The small I/O or paddle boards (see Figure 2-3) are accessed from the rear through a center panel held in place with four M5 screws.
- If the history module is the only application not working, check the Winchester power supply in the bottom of tower #2—the circuit breaker on the supply may be off. Access this breaker through the rear center-section of tower #2.

To isolate a failed board, power supply, fan assembly, or other Optimum Replaceable Unit (ORU), follow the service procedures provided in the *8-Node Multinode Module Service* manual in the *Implementation/8-Node Enhanced Micro TDC 3000* binder.

Service Information for the cartridge drives and the ASPI-41 printer is provided in *Universal Station Service* in the *LCN Service - 1* binder.

## 6.5 SPARE PARTS

**Table 6-4 — Parts List**

PART NUMBER	DESCRIPTION	
51196739-100	Document Reference	Micro TDC Configurations
* 51195652-100	20" CRT	Color Monitor
51195904-006	20" CRT I/C CABLE	Cable from Transition Panel to CRT
51190921-100	20" CRT POWER CORD	120 V Power Cord for CRT
51190921-200	20" CRT POWER CORD	240 V Power Cord for CRT
* 51196075-100	21" CRT	21-Inch FST Desk-Top Color Monitor
* 51196363-100	21" CRT	21-Inch Multi-Sync CRT Color Monitor
* 51197007-100	TOUCHSCREEN FOR 21" CRT	T/S for 21" FST Desk-Top Color Mon. (1)
51197019-100	TOUCHSCREEN FOR 21" CRT	T/S for 21" Multi-Sync Color Monitor (1)
* 51197005-100	CONTROL BOX	Control Box for 21" Touchscreen (1)
51195904-XXX	CABLE SET	Video Copier to EPDG Cable
* 51302287-100	MICRO CABLE	Micro cable for 21" Touchscreen (1)
* 51302297-100	UTDC CABLE	UTDC cable for 21" Touchscreen (1)
* 51108385-508A	M4X8 SCREWS-21" TCH SCRNS	Cable connector Screws at M/F (1)
* 51195904-106	21" CRT CABLE	21-Inch RT Data Cable
51303654-092	AC 125 V POWER CORD	AC Cable for Winchester Power Supply
51303655-092	AC 250 V POWER CORD	AC Cable for Winchester Power Supply
* 51201201-600	AIR FILTER	Air Filter in the top of each tower
* 51108305-100	ASPI 41 PRINTER	Printer

(Continued)

\* ORU Level Replacement Item

(1) Complete 21" Touchscreen Asm. available by ordering: MX-MTTS11-100 (not including monitor)

Table 6-4 — Parts List (Continued)

PART NUMBER	DESCRIPTION	
51190921-110	PRINTER POWER CORD	120 V Printer Power Cord
51190921-210	PRINTER POWER CORD	240 V Printer Power Cord
* 51400975-100	AUX STA ENGINEERS KEYBD	Engineer's Keyboard
* 51195156-200	BETA 20	Cartridge Drive
* 51108305-700	BLACK RIBBON	Ribbon for ASPI-41 Printer
30731611-001	CABLE ASSEMBLY	PLCI I/O Board to PLCG Relay Panel
51304787-100	CRT I/F CABLE	CRT Adapter Cable inside Enclosure
51304396-100	CRTG DISK INTERFACE CBL	From EPDGP I/O to Cartridge Drives
51304392-200	DISK DC POWER CABLE	DC from Winchester P. S. to WREN III
* 51107144-101	FUSE, 3 A 250 V	Fuse for ASPI-41 Printer
* 51401577-100	ENHCD OPER KEYBD ASM	QWERTY Operator's Keyboard
51304788-046	KEYBD ADAPTER CABLE	From Termination Panel to EPDGP I/O
* 51400997-100	PLCI BOARD	PLC Interface Board
* 51195096-100	PLCI/O ADAPTER	PLCI Paddleboard
51195096-200	PLCI I/O BOARD - EMC	PCLI I/O Interface Board
* 51304421-100	PLCI RELAY SWITCH	Panel on rear of Multinode Module
51304421-100	PLCG RELAY SWITCH - EMC	PLCG Relay Board
51304789-100	OPER KEYBD I/C CABLE	From Keyboard to Termination Panel
51303508-100	POWER CORD	125V Power Cord for Tower
51303508-200	POWER CORD (250V)	250V Power Cord for Tower
* 51107144-102	PRINT HEAD	Print Head for ASPI-41 Printer
51304506-100	PRINTER ADAPT CABLE	Adapter Cable inside Enclosure
51303631-003	PRINTER I/F CABLE	Tower to Printer Cable
51304514-100	RS232 DATA CABLE	PLCG Field Port Cable
51304776-100	TP485 BOARD	TPLCN Interface Board
51304776-200	TP485 BOARD	TPLCN Interface Board
51304776-300	TP485-3 BOARD - EMC	TPLCN Interface Board
51304776-400	TP485-4 BOARD - EMC	TPLCN Interface Board
51304507-100	TPLCN NON TERMINATED	Twisted Pair LCN Cable w/o termination
51304505-100	TPLCN TOWER TO TOWER CBL	Connects between Towers
51304505-200	10 M TWR TO TWR CABLE OPN	10 meters Cable between Towers
51195992-100	FLAT TOUCHSCREEN ASM	Touchscreen for 20" CRT
* 51108306-100	TRACKBALL	Trackball and attached cable
51304502-100	TRACKBALL I/F CABLE	Adapter Cable inside enclosure

\* ORU Level Replacement Item

**Table 6-4 — Parts List (Continued)**

PART NUMBER	DESCRIPTION	
* 51107595-100	WINCHESTER PS	Power Supply
* 51196243-100	445 MEGABYTE DRIVE	History Module Hard Disk Drive
* 51196680-100	512 MEGABYTE DRIVE	History Module Hard Disk Drive
51304395-100	WREN INTF CABLE	Signal Cable from SPC I/O to WREN III
51109181-010	LCN CABLE SET	Standard cable set (for LCN Upgrade)
51401551-XXX	K2LCN BOARD	High Performance Processor w/Memory
* 80360206-001	CLI BOARD	Computer Interface Board
* 51196701-100	CLI/A - EMC	Computer Interface Board (RS449)
80360209-001	CLI I/O ADAPTER	CLI Paddleboard (RS232D)
80360230-001	CLI I/O ADAPTER	CLI Paddleboard (RS449)
51401669-100	FAN ASSEMBLY	Micro Fan Module Assembly

\* ORU Level Replacement Item

**Table 6-5— Parts List, LCN Upgrade for 3, 4, 5, or 6 Nodes**

PART NUMBER	DESCRIPTION	
51109806-002	LCN CABLE SET (RG59)	Two Meter Cable Set
30732052-001	BNC PLUG TERMINATOR	Termination Module
51107403-100	LOCAL CNTL NTWK TRNSCV	Local Control Network Transceiver
51190728-105	CONN BNC	T Connector

Spare parts for the Multinode Module and its components (fan, power supply, boards, etc.) are listed in the *8-Node Multinode Module Service* manual in the *Implementation/8-Node Enhanced Micro TDC 3000* binder. Spare parts for the Five/Ten-Slot Module and its components (fan, power supply, boards, etc.) are listed in the *Five/Ten-Slot Module Service* manual in the *LCN Service - 2* binder.

## 6.6 HARDWARE VERIFICATION TEST SYSTEM (HVTS) OVERVIEW

Detailed test-system loading and set-up instructions are provided in the *Test System Executive* and *Hardware Verification Test System* manuals listed in subsection 1.5 of this manual. Subsection 1.4 of this manual contains cartridge handling and loading instructions.

A successful pass through each of the following subsystem test programs ensures that the system hardware and firmware elements are functional, and that the system is ready for the operational software required for system startup:

- Local Control Network Exerciser (LCNX)
- Keyboard Subsystem Tests (KEYB)
- PIC/VDG Subsystem Tests (PDGI)
- Smart Controller Magnetic Disk (SCMD)
- Memory Exerciser Module Tests (MEMX)
- Communications Line Interface Tests (CLIF)  
(only if optional Computer Gateway is installed)
- System Clock Exerciser Tests (CLKX)

After the HVTS program is loaded, we recommend you enter the command "CON" for "configuration" to obtain a printout of the node under test. This printout provides you with a record copy of the node hardware configuration.

An example is shown in Figure 6-3. In the example, entries made by the operator are enclosed in boxes. Also, the operator has stepped through three different nodes, obtaining the configuration for each.

```

○ 11:05 NODE 1 ALL ?  ○
19-SEP-1989 11:05:22 Node 1 Universal Station
○ Slot 1 K2LCN 4004, 000A and 300000 Memory Words At 080000 ○
Slot 2 SPDG 44CA, 1F02, 0098, 0099, 0200, 8400, 000E, 0000
○ Slot 3 EPDG 4442, , 640D, F0A3, 0202, , 0F00, 0101 ○

○ 11:05 NODE 1 ALL ?  ○
11:05 NODE 5 ALL ?  ○
19-SEP-1989 11:05:30 Node 5 Application Module
○ Slot 1 K2LCN 4003, 0008 and 200000 Memory Words At 080000 ○

○ 11:05 NODE 5 ALL ?  ○
11:05 NODE 6 ALL ?  ○
19-SEP-1989 11:05:39 Node 6 History Module
○ Slot 1 K2LCN 4203, 000A and 200000 Memory Words At 080000 ○
Slot 2 SPC 43C1, 0700, 0798, 0798, 0500, 4000, 2003, 0101 ○
○ ○

```

**Figure 6-4 — CONfiguration Sample Printout**

6467

### NOTE

You may notice some apparent discrepancies between the printout obtained above and the physical boards actually found in the equipment. For example, software is made to “think” a physical EPDG board occupies two board-slots. Software reports the first “slot” is occupied by an “SPDG” board and the second, nonexistent “slot” contains an “EPDG.”

If you enter the "REV" command, the revision of the hardware (HW) and firmware (FW) will be displayed, as illustrated in Figure 6-4. Again, entries made by the operator are enclosed in boxes in this example. The operator has again stepped through three nodes, obtaining the revisions for each.

```

○ 11:09 NODE 1 ALL ?  ○
○ 19-SEP-1989 11:09:05 Node 1 Universal Station ○
○ Slot 1 K2LCN HW Ver 4 Rev A FW Ver 0 Rev A Type 1 1 Lowest Acceptable ○
○ Slot 2 SPDG HW Ver 2 Rev E FW Ver 1 Rev E Type 1 1 HW Ver 0 Rev A ○
○ Slot 3 EPDG HW Ver 2 Rev E FW Ver 1 Rev E Type 1 1 HW Ver 0 Rev A ○
○ 11:09 NODE 1 ALL ?  ○
○ 11:09 NODE 5 ALL ?  ○
○ 19-SEP-1989 11:09:14 Node 5 Application Module ○
○ Slot 1 K2LCN HW Ver 3 Rev A FW Ver 0 Rev A Type 1 1 Lowest Acceptable ○
○ 11:09 NODE 5 ALL ?  ○
○ 11:09 NODE 6 ALL ?  ○
○ 19-SEP-1989 11:09:21 Node 6 History Module ○
○ Slot 1 K2LCN HW Ver 3 Rev C FW Ver 0 Rev B Type 1 1 Lowest Acceptable ○
○ Slot 2 SPC HW Ver 1 Rev D FW Ver 0 Rev D Type 1 1 Hw Ver 1 Rev A ○
○

```

**Figure 6-5 — REVersion Sample Printout**

6468





## PREBUILT POINTS Appendix A

### AM POINTS

Parameter	AM_REG	Parameter	AM_REG
NAME	"AM_REG"	RBOPT	NORATBI
UNIT	02	PIDFORM	IDEAL
PTDESC	"AM REGULATORY PID"	CTLEQN	EQB
EUDESC	"DEG. K"	INITTYPE	EXT
KEYWORD	"TEMP"	CTLACTN	REVERSE
PRIMMOD	-----	GAINOPT	LIN
PTDISCL	FULL	K	0.5
PVALGID	DATAACQ	T1	0.5
CTLALGID	PID	T2	0.0
OVERVAL	25	PVTRACK	TRACK
SUPPIO	NOSUPPR	NOCINPTS	0
PERIOD	5SEC	NOCOPTS	1
BEFAFT	NO	CODSTN(1)	PM_REG.SP
PVFORMAT	D1	COACTSTS(1)	ACTIVE
PVEUHI	500.0	OPLOLM	-5.0
PVEULO	0.0	OPMCHLM	0.0
PVEXEUHI	500	OPROCLM	-----
PVEXEULO	0	PVALDB	HALF
PVCLAMP	CLAMP	PVHITP	480
PVSRCOPT	ALL	PVLOTP	10
PVSOURCE	AUTO	PVHHTP	500
PVFLTOPT	SINGLLAG	PVLLTP	-----
TF	0.0	PVROCPTP	-----
NOPINPTS	1	PVROCNTP	-----
PISRC(1)	PM_REG.OPEU	PVSGCHTP	-----
PIDSTN(1)	P1	DEVHITP	-----
PIACTSTS(1)	ACTIVE	DEVLOTP	-----
NMODE	AUTO	ALENBST	ENABLE
NMODATTR	OPERATOR	ALPRIOR	LOW
MODEPERM	PERMIT	CCINPT	NO
EXTSWOPT	NONE	CLSLOTS	0
SPHILM	490	NOPKG	0
SPLOLM	0	NUMSWTCH	0
SP	200	NOGINPTS	0
SPOPT	TV	NOGOPTS	0
OPHILM	105		

## APM POINTS

Parameter	APM_REG	Parameter	APM_REG
NAME	"PM_REG"	CTLACTN	REVERSE
PNTFORM	FULL	GAINOPT	LIN
PNTDESC	PM REGULATORY POINT	K	0.5
EUDESC	"K KG/HR "	T1	0.2
KEYWORD	"FLOW"	T2	0.1
UNIT	01	NOCINPTS	1
NIWKNUM	01	CISRC(1)	PM_REG.OPEU
NODENUM	03	NOCOPTS	1
SLOTNUM	1	CODSTN(1)	PM_AOC.OP
CTLALGID	PID	OPHILM	105.0
PVEUHI	500.0	OPLOLM	-5.0
PVEULO	0.0	SAFEOP	-5.0
PVFORMAT	D1	OPMCHLM	0.0
PVSRCOPT	ALL	OPROCLM	-----
PVSOURCE	AUTO	PVHITP	470
OVERVAL	25	PVHIPR	LOW
RCASOPT	SPC	PVLOTLP	10
SHEDTIME	10	PVLOPR	LOW
SHEDMODE	MAN	PVHHTP	490
NMODE	CAS	PVHHPR	HIGH
NMODATTR	OPERATOR	PVLLTP	5
MOEPRM	PERMIT	PVLLPR	HIGH
EXTSWOPT	NONE	PVSGCHTP	----
SPHILM	480	PVROCPTP	----
SPLOLM	-----	PVROCNTP	----
SP	200	BADPVR	HIGH
SPOPT	TV	DEVHITP	----
PIDFORM	IDEAL	DEVLOTP	----
CTLEQN	EQA	ALENBST	ENABLE
PVTRACK	TRACK	PRIMOD	-----

Parameter	APM_RPV	Parameter	APM_RPV
NAME	"APM_RPV"	PVSRCOPT	ALL
PNTFORM	FULL	PVSOURCE	AUTO
PNTDESC	"APM REGULATORY PV POINT"	TF	0.100000
EUDESC	"ANSWER "	PVTIV	12025.00
KEYWORD	"MATH "	OVERVAL	25
UNIT	01	N	1
NIWKNUM	01	C1	0.000000
NODENUM	3	C2	15.300000
MODNUM	0	C3	3.141519
SLOTNUM	1	C4	1.414000
PRIMOD	--	CALCEXP	"C1=LOG(C3*SQR(P1)/2*C4;MIN(C1,C2) "
USERID	"-----"	PISRC(1)	APM_REG.PV
PVALGID	CALCULTR	PVALDB	ONE
PVEUHI	25000.00	PVHITP	----
PVEULO	0.000000	PVLOTLP	----
PVFORMAT	D1	PVROCPTP	----
PVEXEUHI	5000.00	PVROCNTP	----
PVEXEULO	0.000000	BADPVR	NOACTION
PVCLAMP	NOCLAMP	ALENBST	ENABLE

Parameter	APM_LOG	Parameter	APM_LOG
NAME	"APM_LOG"	LODSTN(5)	----.----
PNTFORM	FULL	LOENBLE(5)	FL2
PNTDESC	"APM LOGIC POINT"	LOSRC(6)	FL1
LOGMIX	12_16_8	LODSTN(6)	----.----
UNIT	01	LOENBLE(6)	FL2
NTWKNUM	01	LOSRC(7)	FL1
NODENUM	3	LODSTN(7)	----.----
SLOTNUM	001	LOENBLE(7)	FL2
LISRC(1)	PM_LOG.FL(7)	LOSRC(8)	FL1
LISRC(2)	PM_LOG.FL(8)	LODSTN(8)	----.----
LISRC(3)	PM_LOG.FL(9)	LOENBLE(8)	FL2
LISRC(4)	PM_LOG.FL(10)	NODESC	3
LISRC(5)	PM_LOG.FL(11)	GENDESC(1)	"S01 OUT"
LISRC(6)	PM_LOG.FL(12)	PRMDESC(1)	S01
LISRC(7)	PM_REG.OP	GENDESC(2)	"ENABLE"
LISRC(8)	----.----	PRMDESC(2)	S01
LISRC(9)	----.----	GENDESC(3)	"OUTPUT"
LISRC(10)	----.----	PRMDESC(3)	S01
LISRC(11)	----.----	ALENBST	ENABLE
LISRC(12)	----.----	C1PR	LOW
LIBADOPT	OFF	C1DESC	" "
NN(1)	25	C1SRC	NONE
FL(7)	OFF	C2PR	LOW
NN(2)	35	C2DESC	" "
FL(8)	ON	C2SRC	NONE
NN(3)	1.414	C3PR	LOW
FL(9)	OFF	C3DESC	" "
NN(4)	3.14159	C3SRC	NONE
FL(10)	ON	C4PR	LOW
NN(5)	----	C4DESC	" "
FL(11)	ON	C4SRC	NONE
NN(6)	----	EIPCODE	-----
FL(12)	OFF	LOGALGID(1)	NULL
NN(7)	----	LOGALGID(2)	NULL
NN(8)	----	LOGALGID(3)	NULL
LOSRC(1)	S01	LOGALGID(4)	NULL
LODSTN(1)	APM_FLG.PVFL	LOGALGID(5)	NULL
LOENBLE(1)	FL2	LOGALGID(6)	NULL
LOSRC(2)	S02	LOGALGID(7)	NULL
LODSTN(2)	APM_LOG.FL(10)	LOGALGID(8)	NULL
LOENBLE(2)	FL2	LOGALGID(9)	NULL
LOSRC(3)	S03	LOGALGID(10)	NULL
LODSTN(3)	APM_LOG.FL(11)	LOGALGID(11)	NULL
LOENBLE(3)	FL2	LOGALGID(12)	NULL
LOSRC(4)	S04	LOGALGID(13)	NULL
LODSTN(4)	APM_LOG.FL(12)	LOGALGID(14)	NULL
LOENBLE(4)	FL11	LOGALGID(15)	NULL
LOSRC(5)	FL1	LOGALGID(16)	NULL

Parameter	APM_NUM	Parameter	APM_NUM
NAME	"APM_NUM"	NTWKNUM	01
PNTFORM	FULL	NODENUM	03
PTDESC	"APM_NUMERIC "	SLOTNUM	1
EUDESC	"REAL"	PV	666.6
KEYWORD	"NUMBER"	PVFORMAT	D1
UNIT	01		

Parameter	APM_AOC	Parameter	APM_AOC
NAME	"APM_AOC"	OPTDIR	DIRECT
PNTFORM	COMPONNT	OPCHAR	ON
PTDESC	"	OPIN1	0.000000
EUDESC	"????????"	OPOUT1	0.000000
KEYWORD	"????????"	OPIN2	33.00000
UNIT	01	OPOUT2	33.00000
NTWKNUM	01	OPIN3	66.00000
NODENUM	3	OPOUT3	66.00000
MODNUM	2	OPIN4	100.0000
SLOTNUM	2	OPOUT4	100.0000
PNTMODTY	AO		

Parameter	APM_DC	Parameter	APM_DC
NAME	"APM_DC"	ST1-OP1	OFF
PNTFORM	FULL	ST0-OP1	OFF
PTDESC	"APM DIGITAL COMPOSITE"	ST2-OP1	ON
EUDESC	" "	ST1-OP2	OFF
KEYWORD	"PUMP"	ST0-OP2	ON
UNIT	01	ST2-OP2	OFF
NIWKNUM	01	ST1-OP3	ON
NODENUM	03	ST0-OP3	OFF
SLOTNUM	1	ST2-OP3	OFF
PRIMOD		DODSTN(1)	APM_DOC.SO
USERID	" "	DODSTN(2)	APM_LOG.FL(7)
NOSTATES	3	DODSTN(3)	APM_LOG.FL(8)
NODINPTS	2	PULSEWTH	10.0
NODOPTS	3	STCHGOPT	NONE
PVTXTOPT	OFF	SEALOPT	NONE
STATETXT(1)	"RUN "	MAINOPT	NONE
STATETXT(0)	"STOP "	NMODATTR	OPERATOR
STATETXT(2)	"JOG "	MODEPERM	PERMIT
BOXCLR(1)	GREEN	OROPT	OFF
BOXCLR(0)	YELLOW	PVNORMAL	NONE
BOXCLR(2)	RED	FBTIME	0
MOMSTATE	NONE	SIOALOPT	NONE
DISRC(1)	APM_DIF.PVFL	SIODESC	" "
DISRC(2)	APM_FLG.PVFL	OVRDALOP	NONE
D2D1_00	MOVPV	I1DESC	" "
D2D1_01	PVSTATE1	I0DESC	" "
D2D1_10	PVSTATE0	I2DESC	" "
D2D1_11	BADPV	BADPVPR	LOW
PVSRCOPT	ALL	EVOPT	NONE

Parameter	APM_FLG	Parameter	APM_FLG
NAME	"APM_FLG"	STATETXT(1)	"BUSY"
PNTFORM	FULL	STATETXT(0)	"FREE"
PNTDESC	"PM FLAG POINT"	PV	BUSY
KEYWORD	"FLAG"	BOXCLR(1)	WHITE
UNIT	01	BOXCLR(0)	GREEN
NIWKNUM	01	ALPRIOR	NOACTION
NODENUM	03	ALENBST	ENABLE
SLOTNUM	1	EIPPCODE	-----

Parameter	APM_SEQ	Parameter	APM_SEQ
NAME	"APM_SEQ"	USERID	"-----"
PNTFORM	FULL	STRLEN	8
PNTDESC	"APM SEQUENCE PROGRAM"	SEQSLTSZ	20
UNIT	01	CNTLLOCK	OPERATOR
NTWKNUM	01	SPLOCK	OPERATOR
NODENUM	3	RSTROPT	RESTART
SLOTNUM	1	ACP	--
PRIMOD	--	SEQPR	NOACTION

Parameter	APM_DIF	Parameter	APM_DIF
NAME	"APM_DIF"	STATETXT(1)	"OPEN"
PNTFORM	FULL	STATETXT(0)	"CLOSED"
PNTDESC	"APM FULL DIGITAL INPUT"	BOXCLR(1)	GREEN
EUDESC	"BLOCK"	BOXCLR(0)	BLUE
KEYWORD	"VALVE"	INPTDIR	DIRECT
UNIT	01	PVSRCOPT	ALL
NTWKNUM	01	PVSOURCE	AUTO
NODENUM	3	ALMOPT	OFFNORML
MODNUM	3	PVNORMAL	CLOSED
SLOTNUM	1	DLYTIME	10
PRIMOD	--	OFFNRMPR	NOACTION
PNTMODTY	DI	ALENBST	ENABLE
DITYPE	STATUS	EVTOPT	NONE

Parameter	APM_D0C	Parameter	APM_D0C
NAME	"APM_D0C"	NTWKNUM	01
PNTFORM	COMPONNT	NODENUM	3
PTDESC	"	MODNUM	4
EUDESC	"????????"	SLOTNUM	1
KEYWORD	"????????"	PNTMODTY	DO
UNIT	01	DOTYPE	STATUS

Parameter	APM_DIC	Parameter	APM_DIC
NAME	"APM_DIC"	NTWKNUM	01
PNTFORM	COMPONNT	NODENUM	3
PTDESC	"	MODNUM	3
EUDESC	"????????"	SLOTNUM	2
KEYWORD	"?????????"	DITYPE	STATUS
UNIT	01		

Parameter	APM_TMR	Parameter	APM_TMR
NAME	"APM_TMR"	NODENUM	3
PNTFORM	FULL	SLOTNUM	1
PTDESC	"APM_TIMER POINT"	PRIMOD	--
KEYWORD	TIME	TIMEBASE	SECONDS
UNIT	01	SP	0
NTWKNUM	01		

Parameter	APM_AIF	Parameter	APM_AIF
NAME	"APM_AIF"	PVEXEUHI	102.9000
PNTFORM	FULL	PVEXEULO	-2.90000
PTDESC	APM ANALOG INPUT POINT	PVCLAMP	NOCLAMP
EUDESC	"DEF. R"	LOCUTOFF	-----
KEYWORD	"TEMP"	PVSRCOPT	ALL
UNIT	01	PVSOURCE	SUB
NTWKNUM	01	TF	0.250000
NODENUM	3	PVTV	25.00000
MODNUM	1	OVERVAL	25
SLOTNUM	1	PVALDB	HALF
PRIMOD	--	PVHITP	100.0000
PNTMODTY	HLAI	PVHIPR	LOW
SENSRTYP	1_5_V	PVLOTLP	----
PVCHAR	LINEAR	PVHHTP	----
INPTDIR	DIRECT	PVROCPTP	25.00000
PVEUHI	100.0000	PVROCNTP	----
PVEULO	0.000000	BADPVPR	JOURNAL
PVFORMAT	D1	ALENBST	ENABLE

Parameter	APM_AOF	Parameter	APM_AOF
NAME	"APM_AOF"	OPIN1	0.000000
PNTFORM	FULL	OPOUT1	0.000000
PNTDESC	"APM ANALOGOUTPUT POINT"	OPIN2	25.00000
EUDESC	"% OPEN"	OPOUT2	50.00000
KEYWORD	"VALVE"	OPIN3	50.00000
UNIT	01	OPOUT3	70.70000
NTWKNUM	01	OPIN4	100.0000
NODENUM	3	OPOUT4	100.0000
MODNUM	2	RCASOPT	DDC
SLOTNUM	1	NMODE	CAS
PRIMMOD	--	NMODATTR	NONE
OPTDIR	DIRECT	MODEPERM	PERMIT
OPCHAR	ON		

Parameter	APM_AIC	Parameter	APM_AIC
NAME	"APM_AIC"	SENSRTYP	1_5_V
PNTFORM	COMPONNT	PVCHAR	LINEAR
PTDESC	"	INPTDIR	DIRECT
EUDESC	"?????????"	PVEUHI	300.0000
KEYWORD	"?????????"	PVEULO	0.000000
UNIT	01	PVFORMAT	D1
NTWKNUM	01	PVEXEUHI	350.0000
NODENUM	3	PVEXEULO	50.00000
MODNUM	1	PVCLAMP	NOCLAMP
SLOTNUM	2	LOCUTOFF	-----
PNTMODTY	HLAI	TF	0.000000



# BUTTON CONFIGURATION Appendix B

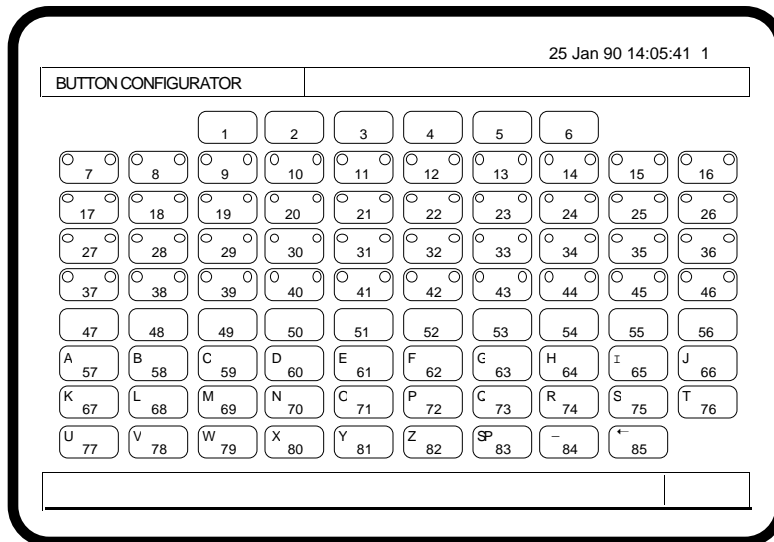

Figure B-1 — Button Configuration Menu - Operator's Keyboard

3252

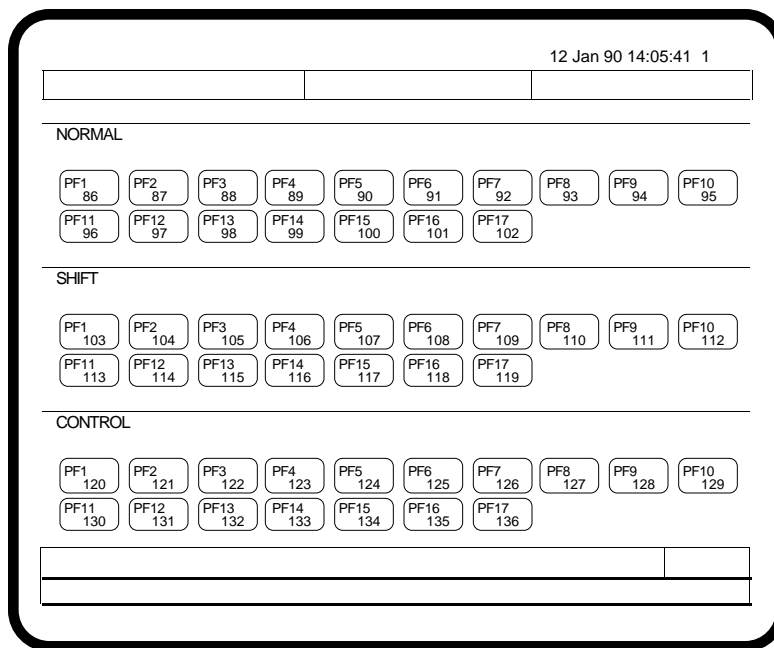

Figure B-2 — Button Configuration Menu - Engineer's Keyboard

3327

<u>Button</u>	<u>Action</u>
1	CROSSCRN(01)
2	CROSSCRN(02)
5	CLR_CRN(01)
6	CROSSCRN(2);CLR_CRN
7	KEY(02,GROUP)
8	KEY(02,DETAIL)
9	KEY(02,SEVEN)
10	KEY(02,EIGHT)
11	KEY(02,NINE)
12	KEY(02,MAN)
13	KEY(02,AUTO)
14	KEY(02,NORM)
17	KEY(02,UNT_TRND)
18	KEY(02,TREND)
19	KEY(02,FOUR)
20	KEY(02,FIVE)
21	KEY(02,SIX)
22	KEY(02,SP)
23	KEY(02,OUT)
27	KEY(02,FAST)
28	KEY(02,SLOT)
29	KEY(02,ONE)
30	KEY(02,TWO)
31	KEY(02,THREE)
32	KEY(02,RAISE);DELAY(0,0,500);KEY(02,RAISE_RL)
33	KEY(02,FSTRAISE);DELAY(0,0,500);KEY(02,FSTRASRL)
37	KEY(02,SCHEM)
38	KEY(02,HELP)
39	KEY(02,PERIOD)
40	KEY(02,ZERO)
41	KEY(02,DASH)
42	KEY(02,LOWER);DELAY(0,0,500);KEY(02,LOWER_RL)
43	KEY(02,FAST_LOW);DELAY(0,0,500);KEY(02,FSTLWRL)
48	KEY(02,HOUR_AVG)
49	KEY(02,ENTER)
50	KEY(02,CLR_ENT)
51	KEY(02,SELECT)
52	KEY(02,TAB_UP)
57	KEY(02,PRR_DISP)
58	KEY(02,ASC_DISP)
60	KEY(02,ACK)
61	KEY(02,TAB_LEFT)
62	KEY(02,TAB_DOWN)
63	KEY(02,TAB_RGHT)
67	KEY(02,DISP_BK)
68	KEY(02,DISP_FWD)
69	KEY(02,MSG_SUMM)
70	KEY(02,ALM_SUM)

<u>Button</u>	<u>Action</u>
71	KEY ( 02 , ALM_ANNC )
77	KEY ( 02 , PAGE_FWD )
78	KEY ( 02 , PAGE_BK )
79	KEY ( 02 , MSG_CNFM )
80	KEY ( 02 , MSG_CLR )
81	KEY ( 02 , U_ALM_SM )
86	QUE_KEY ( SCHEM )
87	QUE_KEY ( PRR_DISP )
88	QUE_KEY ( GROUP )
89	QUE_KEY ( DETAIL )
90	CLR_SCRN
91	QUE_KEY ( SYS_STAT )
92	QUE_KEY ( CON_STAT )
93	QUE_KEY ( SYS_MENU )
94	CROSSCRN ( 1 )
95	UPDATE ( 0 , 2 )
96	QUE_KEY ( ALM_SUMM )
97	MSGSUM
98	CROSSCRN ( 2 )
99	UNITSUM
100	QUE_KEY ( MAN )
101	QUE_KEY ( AUTO )
102	QUE_KEY ( NORM )
103	QUE_KEY ( ASC_DISP )
104	QUE_KEY ( DISP_FWD )
105	QUE_KEY ( SLOT )
106	QUE_KEY ( PAGE_FWD )
107	CROSSCRN ( 01 ) ; CLR_SCRN
109	UCN_STAT ( 1 )
110	REP_MENU
111	CROSSCRN ( 2 )
112	QUE_KEY ( FAST )
113	QUE_KEY ( SIL )
114	QUE_KEY ( MSG_CNFM )
115	CROSSCRN ( 1 )
117	QUE_KEY ( OUT )
118	QUE_KEY ( SP )
119	QUE_KEY ( RAISE )
120	QUE_KEY ( HELP )
121	QUE_KEY ( DISP_BK )
122	QUE_KEY ( TREND )
123	QUE_KEY ( PAGE_BK )
124	CROSSCRN ( 02 ) ; CLR_SCRN
126	PM_STAT ( 1 , 3 )
127	EHR
129	KEY ( 01 , FAST ) ; KEY ( 02 , FAST )
130	QUE_KEY ( ACK )
131	QUE_KEY ( MSG_CLR )
136	QUE_KEY ( LOWER )



---

# Index

---

Topic	Section Heading
AC Voltage	2.3.1
Access, Keyswitch	5.3.3
Access, Password	5.3.3
Address, Node	6.2
After Startup	1.2.2
Air Filter	
Inspection	6.3.1
Removal and Cleaning	1.2.2, 6.3.1
Replacing	6.3.1
Alarm, Fan	3.1.1
Alphanumeric Display	3.1.1
AM	1.1.1
AM, Loading	5.2.1
Amperes	2.3.3
Annunciator Horn	1.1.3
Application Module (AM)	1.1.1
Area Database	5.3.1
Configuration	4.8
Configuration Data	4.8.2
Authorized Personnel	1.2.2
Autoboot	3.1.2, 5.2.3
Disabling	5.2.3
Automatic Boot	3.1.2
Avoiding ESD Damage	1.3
Bags, Protective	1.3
Basic Enhanced Micro TDC 3000 Systems	1.1.1
Before Startup	1.2.1
Bootload	3.1.2
Automatic	5.2.3
From Power Off	5.1.1.1
Bootloading US from Cartridges	5.1.1.2
Bootloading US from the HM	5.1.1.1
Bubble Pack Material	1.3
Build Free Format Logs	4.7.2
Build Pictures	4.7.1
Cabinet	See "Tower"
Cable Dress	2.10

---

# Index

---

Topic	Section Heading
Cabling	2.7, 2.8
Color Monitor	2.7.5
Computer Gateway	2.8.3
Diagrams	2.7.13, 2.7.14
Engineer's Keyboard	2.7.6
EPDG I/O	2.7.2
EPDGC I/O	2.7.4
PLCG	2.8.4
Printer	2.7.3
Redundant NIM	2.8.2
Second Printer	2.8.1
Second Trackball	2.8.1
Second Universal Station	2.8.1
Touchscreen	2.7.7
Trackball	2.7.8
Cartridge Disk	
Bootload From	5.1.1.2
Do's/Don'ts	1.4
Drive	1.1
Handling	1.4
Storage	1.4
Cleaning	1.2.2
Insertion	1.4.1
Orientation	1.4.1
Protect	1.4.2
Removal	1.4.1
Write Protect	1.4.2
Cartridge Drive	
Checks	3.1.5
Cleaning	1.2.2
Power	3.1.5
Ready	1.4.1
Shipping Inserts	2.9
Shutter	1.4.1
Stopped	1.4.1
Cartridge	
Loading	1.4.1
Media	See "Cartridge Disk"
Media Protection	1.4.2
Removal	1.4.1
CEE	2.2
CG	1.1.2, 4.2.1
Changing Area Database	5.3.2.1
Changing Passwords	5.3.3.2
Changing US Personalities	5.1.1.3
Checks	
Cartridge Drive	3.1.5
Color Monitor	3.1.3
Preliminary	6.4
Printer	3.1.4
Tower #1	3.1.1

---

# Index

---

Topic	Section Heading
Checkout	3, 3.2
Circuit Card	
Defective	1.3
Handling	1.3
Locations	2.7, 3.1.1
Protection	1.3
Shipping	1.3
Class C Environment	2.2
Cleaner, Vacuum	1.2.2
Cleaning	1.2.1, 6.3
Air Filters	1.2.2
Cartridge Disk	1.2.2
Cartridge Drive	1.2.2
Color Monitor	1.2.2
General	1.2.1
Keyboard	1.2.2
Printer	1.2.2
Schedule	1.2.1
System Area	1.2.2
CLI I/O	2.8.4
CLI I/O Cabling	2.8.4
CLIF	6.6
CLKX	6.6
CL Program Preparation	4.7.4.1
Closet	1.2.1
Coat Rack	1.2.1
Color Monitor	1.1
Adjustments	5.4, 6.2.3
Cabling	2.7.5
Check	3.1.3
Cleaning	1.2.2
Communications Network	1.1.5
Computer	
Cable Maximum	2.8.3
Connection	2.7
Gateway	2.8.3
Gateway (CG)	1.1.2
Gateway Cabling	2.8.3
Host	2.8.3
Redundant Cable	2.8.3
Configuration Printout	6.6
Configuration	
Area Database	4.8
Network	4.2.1
Button	B
UCN/PM Box Point	4.4.3
Configure Buttons	4.7.3

---

# Index

---

Topic	Section Heading
Connection	
Computer	2.7
CRT	2.7
Electrical	2.7
Keyboard	2.7.2
Printer	2.7
Process Cabling	2.7.1
Signal	2.7
TPLCN	2.7
Trackball	2.7
Trackball	2.7.4
UCN Cable	2.7
UCN Ground	2.7.1
Cords, Electric	2.2
Cover Removal, Rear	2.7
CRT	see "Color Monitor"
CRT Connection	2.7
Current in Amperes	2.3.3
Current, Inrush	2.3
Damage	
Electrical	2.6
Physical	2.4
Database Configuration Data	4.8.2
Desktop	1.1
Orientation	2.6
Diagnostic, Printer	3.1.4.2
Dimensions	2.2.1
Disabling Autoboot	5.2.3
Display, Console Status	5.1.1
Display, Status	3.1.1
Dolly, Roller	2.6
Editor, Picture	4.7.1
Electric Cords	2.2
Electrical	
Connections	2.7
Failure	1.1.2
Requirements	2.3
ElectroMagnetic Compatibility (EMC) Directive	1.5, 2.7, 2.8
Electrostatic Discharge	1.2.1, 1.4.1
Engineer's Keyboard	1.1.4
Cabling	2.7.6
Deny Access	1.1.4
Disconnecting	1.1.4
Keylock	4.2.1.1
Lockout	1.1.4
Personality	4.2.1.1
Reconnecting	1.1.4
Second	2.8.1
Environment, Class C	2.2
Environment, Office	2.2
EPDG I/O Cabling	2.7.2
EPDGC I/O Cabling (EC)	2.7.4



---

# Index

---

Topic	Section Heading
Equipment	
Cabling	2.7, 2.8
Checkout	3
Moving	2.7
Error LED	3.1.1
ESD	1.2.1, 1.3
Exerciser	
Local Control Network (LCNX)	6.6
System Clock (CLKX)	6.6
Fabrics, Synthetic	1.2.1
Fan Alarm	3.1.1
Field Adjustment	6.2
Fire	
Extinguishing	1.2.2
Fighting	1.2.2
Floor Loading	2.2.1
Flooring, Level	2.7
Free Format Logs, Building	4.6.3
Frequency	
Cleaning	1.2.2, 6.3.1
Electrical	2.3.2
Front Cover	
Removal	3.1.1
Replace	3.1.1
G-Forces	2.2
General Description	1.1
Green LED	3.1.1
Ground, TPLCN	2.7.6
Guidelines, Operational	5
Hand Truck	2.6
Handling	
Cartridge Disk	1.4
Circuit Cards	1.3
Hardware Verification Test System	6.6
Hazard, Personnel	2.7
History Module (HM)	1.1, 1.1.1
HM	1.1.1
Loading	5.2.3
Housekeeping	1.2
How to	
Bootload US with Operator Personality from Cartridges	5.1.1.2
Bootload US1 with Oper. Personality from Preloaded HM	5.1.1.1
Change a US's Personality	5.1.1.3
Change the Area Database	5.3.1.1
Load a US from Another Operating US	5.1.1.5
Load and Change US Personalities	5.1.1
Humidity	1.2.2
Storage	2.1
HVTS	6.6

---

# Index

---

Topic	Section Heading
Implementation	4
Overview	4.1
Process	4.1.2
Indicator, Test	3.1.1
Inrush Current	2.3
Insert,Keyboard	1.1.3
Inspection, Air Filter	6.3.1
Installation	2, 2.6, 2.9
Introduction	1
Jumper, Margin	3.1.1
KEYB	6.6
Keyboard	1.1
Engineer's	1.1.4
Chemically Resistant	1.1.3
Cleaning	1.2.2
Connection	2.7, 2.7.2
Free-standing	1.1.4
Insert	1.1.3
Insert, Replacing	1.1.3
Membrane	1.1.3
Operator's	1.1.3
Power	2.7.2
Second Engineer's	2.8.1
Second Operator's	2.8.1
Spills	1.2.2
Template	1.1.3
Keylock, Engineering	4.2.1.1, 5.3.3
Keys	
Preconfigured	1.1.3
Unmarked	1.1.3
User Configured	1.1.3
Keyswitch Access	5.3.3
Layout	2.5
LCN	1.1.5
LCN Upgrade	2.9
LCNX	6.6
LED	
Error	3.1.1
Fan Alarm	3.1.1
Green	3.1.1, 3.1.5
Locations	3.1.1
Power OK	3.1.1
Red	3.1.1
Yellow	3.1.1, 3.1.5
Loading	
Application Module	4.3.1, 5.2.1
History Module	5.2.3
Network Interface Module	4.3.2, 5.2.2
PM	4.4, 5.2.2
US from another US	5.1.1.3
US Personalities	5.1.1

---

# Index

---

Topic	Section Heading
Local Control Network	1.1.5
Location	
Circuit Cards	2.7
LEDs	3.1.1
Test Indicator	3.1.1
Mailers, Bubble Pack	1.3
Manuals	1.5
Margin Jumper	3.1.1
Maximum, Computer Cable	2.8.3
Media, Cartridge	See "Cartridge Disk"
MEMX	6.6
Menu, Engineering	5.1
Missing Items	2.4
Monitor	See "Color Monitor"
Monitor Operation	5.4
Moving Equipment	2.7
Multinode Module	1.1
Parts	6.5
NEMA	2.2
Network Interface Module (NIM)	1.1.1
NIM	1.1.1
Loading	4.3.2, 5.2.2
Redundant	1.1.2
NIM MODEM	2.7.1
No Smoking	1.2.1, 1.2.2
Node	
Address, Unique	3.1.1, 3.1.2
Addressing (Pinning)	6.2.1
Loading	4.3, 5
Pinning	6.2.1
Nodes, Total	1.1, 1.1.2
Office Environment	2.2
Operating	
Displays	5.3.1
Practices	1.2
Requirements	2.2
Operating the System	5.3
Operational Guidelines	5
Operator's Keyboard	1.1.3
Operator's Personality	5.1
Optional	
Computer Gateway	2.8.3
PLCG	2.8.4
Redundant Network Interface Module	2.8.2
Options to the System	1.1.2
Options, AC Voltage	2.3.1
Orientation	2.6
Cartridge Disk	1.4.1
Equipment	2.5, 2.6
Overview	1, 6.1

---

# Index

---

Topic	Section Heading
Panel	
Rear	2.7
Transition	2.7
Parts	6.5
Password	5.3.3.2
PDGI	6.6
Personalities	5.1
Personnel, Authorized	1.2.2
Pinning	6.2
Node	6.2.1
TP485	6.2.2
TPLCN	6.2.1
PLC, PLCG	1.1.2, 2.8.4, 4.2.1
PLCG modem	2.2
PM	
Box Point	4.4
Data Point Building	4.6
Data Points	A
Positioning	
Printer	2.6
Towers	2.6
Power OK LED	3.1.1
Power-On Tests	3.1
Prebuilt Data	
Area Database Configuration	4.8
Database Configuration	4.8.2
Network Configuration	4.2.2
UCN/PM Box Point Configuration	4.4.3
Preliminary Troubleshooting	6.4
Preparation of Site	2
Printed Wire Board	See "Circuit Card"
Printer	1.1
Cable	2.7.3
Cabling	2.7.3
Checks	3.1.4
Cleaning	1.2.2
Connection	2.7, 2.7.3
Diagnostic	3.1.4.2
Positioning	2.6
Second	2.8.1
Self-Test	3.1.4.1
Test Message	3.1.4.2
User-Diagnostic Test	3.1.4.2
Printout	
Configuration	6.6
Revision	6.6
Process Cabling	2.7.1
Process Manager	1.1
Protecting	
Cartridge Disk	1.4.2
Cartridge Media	1.4.2
Circuit Card	1.4

---

# Index

---

Topic	Section Heading
Protective Bags	1.3
Protocol	1.1.5
Publications	1.5
PWB	See "Circuit Card"
Radio	
Antenna	1.2.2
Communications	1.2.2
Frequency Interference (RFI)	1.2.2
Interference	1.2.2
Hand-Held	1.2.2
Red LED	3.1.1
Redundant	
Computer	2.8.3
NIM	1.1.2, 2.8.2
Related Publications	1.5
Removal, Air Filter	6.3.1
Removal, Front Cover	3.1.1
Replaced, Front Cover	3.1.1
Replacing Air Filters	6.3.1
Replacing Keyboard Insert	1.1.3
Requirements	
Electrical	2.3
Operating	2.2
Site	2.2
Reset Switch	3.1.1
Resetting the US	5.1.1.2
Revision Printout	6.6
RFI Sources	1.2.2
Roller Dolly	2.6
RS-232	2.8.4
RS-485	1.1.5
Schedule, Cleaning	1.2.1
SCMD	6.6
Second Engineer's Keyboard	2.8.2
Second Operator's Keyboard	2.8.2
Second Printer	2.8.2
Second Trackball	2.8.2
Second Universal Station	1.1.1, 2.8
Optional Universal Station Upgrade	2.8.2
Self-Test, Printer	3.1.4.1
Separation between Towers	2.6
Serial Data, High Speed	1.1.5
Service	6
Setting Time and Date	5.1.1.5
Shipping Defective Circuit Card	1.3
Shipping Inserts, Cartridge Drive	2.9
Signal Connectors	2.7
Site	
Installation	2
Layout	2.5
Preparation	2
Requirements	2.2

---

# Index

---

Topic	Section Heading
Spare Parts	6.5
Start Up	
First-Time	4.2
With an Operable Database on the History Module	4.2, 5.1.1
Static Electricity	1.2.1
Status Display	
Alphanumeric	3.1.1
Console	5.1.1
UCN	5.2.3
Storage Conditions	2.1
Storing Cartridge Disks	1.4
Strain Relief	2.9
Strap, Wrist	1.2.1
Styrofoam	1.3
Switch, Reset	3.1.1
System Checkout	3.2
System Operation	5.3
System Start Up	4.2
TDC 3000 <sup>X</sup>	1
TPLCN Ground	2.7.2
Temperature	1.2.2
Operating	2.2
Storage	2.1
Template, Keyboard	1.1.3
Test Indicator Locations	3.1.1
Test Message, Printer	3.1.4.2
Test	
Communications Line Interface (CLIF)	6.6
Keyboard Subsystem (KEYB)	6.6
Memory Exerciser Module	6.6
PIC/VDG Subsystem (PDGI)	6.6
Power-On	3.1
Smart Controller Magnetic Disk	6.6
System Clock Exerciser (CLKX)	6.6
Tower #1	3.1.1
Time and Date, setting	5.1.1.5
Token-Passing Protocol	1.1.5
Tower	1.1
Tower #1 Electronics Checks	3.1.1
Tower #1 Equipment Cabling	2.7
Tower #2 Electronics Checks	3.1.2
Tower #2 Equipment Cabling	2.8
Tower	
Identification	2.6
Installation	2.6
Positioning	2.6
Separation	2.6
TP485Pinning	6.2.2
TPLCN	1.1.5
Cabling	2.7.7
Connection	2.7
Pinning	6.2.1

---

# Index

---

Topic	Section Heading
Trackball	1.1
Cabling	2.7.4
Connection	2.7, 2.7.4
Second	2.8.1
Traffic	1.2.2
Transition Panel	2.7
Troubleshooting	6.4
Truck, Hand	2.6
Twisted-Pair	1.1.5
UCN	1
Cable Connection	2.7
Drop Cables	2.7.1, 2.8.2
Ground Connection	2.7
Node Entity, NIM	4.2.2
Node Entity, PM	4.4.3
Status Display	5.2.2
Taps	2.7.1, 2.8.2
UCN/PM	
Box Point Configuration data	4.4.3
Box Points	4.5
PM Data Points	4.6
Universal Control Network (UCN)	1.1
Universal Station (US)	1.1.1
Universal Station, Second	2.8.1
Unpacking	2.4
Upgrades	
LCN Upgrade	2.9
Second Operator's Keyboard	2.8.1
Second Universal Station	2.8.2
US	1.1.1
User-Written Programs	4.7.4
Velcro™	2.6
Version A	1.1.1
Version A to Version B Upgrade	2.8.2
Version B	1.1.1
Walkie-Talkies	1.2.2
Weight	2.2.1
Windows Open	1.2.2
Windows Sealed	1.2.1
WREN III	
Drive	3.1.2
Drive Power	6.4
Wrist Strap	1.2.1, 1.3
Write Protect	1.4.2
Write-In-Process	3.1.2
Yellow LED	3.1.1





## READER COMMENTS

Honeywell IAC Automation College welcomes your comments and suggestions to improve future editions of this and other publications.

You can communicate your thoughts to us by fax, mail, or toll-free telephone call. We would like to acknowledge your comments; please include your complete name and address

**BY FAX:** Use this form; and fax to us at (602) 313-4108

**BY TELEPHONE:** In the U.S.A. use our toll-free number 1\*800-822-7673 (available in the 48 contiguous states except Arizona; in Arizona dial 1-602-313-5558).

**BY MAIL:** Use this form; detach, fold, tape closed, and mail to us.

Title of Publication: **8-Node Enhanced Micro TDC 3000 User's Manual** Issue Date: **9/95**

Publication Number: **MT11-520**

Writer: **C. Phillips**

**COMMENTS:** \_\_\_\_\_  
\_\_\_\_\_  
\_\_\_\_\_  
\_\_\_\_\_  
\_\_\_\_\_  
\_\_\_\_\_  
\_\_\_\_\_  
\_\_\_\_\_

**RECOMMENDATIONS:** \_\_\_\_\_  
\_\_\_\_\_  
\_\_\_\_\_  
\_\_\_\_\_  
\_\_\_\_\_  
\_\_\_\_\_  
\_\_\_\_\_

NAME \_\_\_\_\_ DATE \_\_\_\_\_

TITLE \_\_\_\_\_

COMPANY \_\_\_\_\_

ADDRESS \_\_\_\_\_

CITY \_\_\_\_\_ STATE \_\_\_\_\_ ZIP \_\_\_\_\_

TELEPHONE \_\_\_\_\_ FAX \_\_\_\_\_

(If returning by mail, please tape closed; Postal regulations prohibit use of staples.)

Communications concerning technical publications should be directed to:

Automation College  
Industrial Automation and Control  
Honeywell Inc.  
2820 West Kelton Lane  
Phoenix, Arizona 85023-3028

FOLD

FOLD

From: \_\_\_\_\_  
\_\_\_\_\_  
\_\_\_\_\_



NO POSTAGE  
NECESSARY  
IF MAILED  
IN THE USA

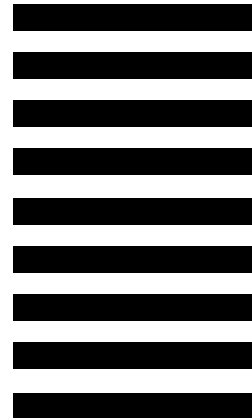

Cut Along Line

**BUSINESS REPLY MAIL**  
FIRST CLASS      PERMIT NO. 4332      PHOENIX, ARIZONA

POSTAGE WILL BE PAID BY ....

**Honeywell**

Industrial Automation and Control  
2820 West Kelton Lane  
Phoenix, Arizona 85023-3028

Attention: Manager, Quality

FOLD

FOLD

Additional Comments:



**Honeywell**

---

**Industrial Automation and Control**  
Honeywell Inc.  
16404 North Black Canyon Highway  
Phoenix, Arizona 85023-3033

*Helping You Control Your World*