



ProcessLogix Hardware

(Cat. No. 1757-PLX52)

This document tells you how to install the components of the ProcessLogix™ system, including the:

- chassis and power supply
- 1756-CNB ControlNet communication module
- 1757-PLX52 Process Controller module
- I/O modules
- ProcessLogix server
- ControlNet cabling

We also help you to understand installation requirements.

TIP



For installation information and specifications for the Redundancy Module, refer to publication 1757-5.15 (shipped with the 1757-SRM Redundancy Module).

For specifications for each module in your system, refer to the documentation that was shipped with the module(s).

IMPORTANT

The 1757-PLX52 Process Controller module is supplied with only the boot code installed. You must configure the module before you can use it in your system. Refer to the ProcessLogix Software Installation Manual, publication 1757-5.74, for more information.

Important User Information

Because of the variety of uses for the products described in this publication, those responsible for the application and use of this control equipment must satisfy themselves that all necessary steps have been taken to assure that each application and use meets all performance and safety requirements, including any applicable laws, regulations, codes and standards.

The illustrations, charts, sample programs and layout examples shown in this guide are intended solely for purposes of example. Since there are many variables and requirements associated with any particular installation, Allen-Bradley does not assume responsibility or liability (to include intellectual property liability) for actual use based upon the examples shown in this publication.

Allen-Bradley publication SGI-1.1, *Safety Guidelines for the Application, Installation and Maintenance of Solid-State Control* (available from your local Allen-Bradley office), describes some important differences between solid-state equipment and electromechanical devices that should be taken into consideration when applying products such as those described in this publication.

Reproduction of the contents of this copyrighted publication, in whole or part, without written permission of Rockwell Automation, is prohibited.

Throughout this manual we use notes to make you aware of safety considerations.

ATTENTION



Identifies information about practices or circumstances that can lead to personal injury or death, property damage or economic loss

Attention statements help you to:

- identify a hazard
- avoid a hazard
- recognize the consequences

IMPORTANT

Identifies information that is critical for successful application and understanding of the product.

Allen-Bradley is a trademark of Rockwell Automation

European Communities (EC) Directive Compliance

If this product has the CE mark it is approved for installation within the European Union and EEA regions. It has been designed and tested to meet the following directives.

EMC Directive

This product is tested to meet the Council Directive 89/336/EC Electromagnetic Compatibility (EMC) by applying the following standards, in whole or in part, documented in a technical construction file:

- EN 50081-2 EMC — Generic Emission Standard, Part 2 — Industrial Environment
- EN 501082-2 EMC — Generic Immunity Standard, Part 2 — Industrial Environment

This product is intended for use in an industrial environment.

Low Voltage Directive

This product is tested to meet Council Directive 73/23/EEC Low Voltage, by applying the safety requirements of EN 61131-2 Programmable Controllers, Part 2 - Equipment Requirements and Tests. For specific information required by EN 61131-2, see the appropriate sections in this publication, as well as the Allen-Bradley publication Industrial Automation Wiring and Grounding Guidelines For Noise Immunity, publication 1770-4.1.

This equipment is classified as open equipment and must be mounted in an enclosure during operation to provide safety protection.

Installation Requirements

Before you begin installing the system, take a moment to review these system installation requirements.

Location

The ProcessLogix system is CSA certified and FM approved non-incendive equipment for installation in Class I, Division 2, Group A, B, C & D hazardous (classified) locations. The user must ensure all parts of the system, and any other equipment in the Division 2 area, are listed for installation in a Class I, Division 2 hazardous (classified) location.

Removal and Insertion Under Power

Some ProcessLogix modules (e.g., I/O and communications modules) as well as the 1757-PLX52 Process Controller module have been designed to permit removal and insertion under power (RIUP) without damaging the module or interrupting backplane communications.

Any time electrical connections are made or broken, there is a potential for arcing or sparking. Do not remove or insert any modules while they are still powered up when you are in a hazardous (potentially explosive) environment.

ATTENTION



The ProcessLogix RIUP feature does not apply to installations that must conform to Division 2 hazardous location requirements. Unless the location is known to be non-hazardous, do not:

- connect or disconnect cables
 - connect or disconnect removable terminal blocks
 - install or remove modules
-

Installing the Chassis and Power Supply

Follow this procedure to install the ControlLogix chassis and power supply.

Before You Begin

Before you begin, gather these tools:

- 1/8" slotted screwdriver
- 1/4" slotted (#2) or phillips screwdriver
- torque screwdriver
- needle-nose pliers
- crimping tool

TIP

Ensure that you have properly calculated the backplane requirements for the power supply you are installing.



Set the Line Voltage Input Jumper

Use needle-nose pliers to set the jumper to the correct position.

IMPORTANT

The "HI" and "LOW" positions are marked on the power supply's circuit board

for this power supply	set jumper to this position
1756-PA72 (120V ac)	low (default)
1756-PA72 (240V ac)	high

Install the Power Supply

1. Align the power supply's circuit board with the card guides on the left side of the chassis
2. Slide the power supply in until it is flush with the chassis.
3. Tighten the screw holding the power supply to the chassis.
4. Connect safety ground from the power supply to the chassis.

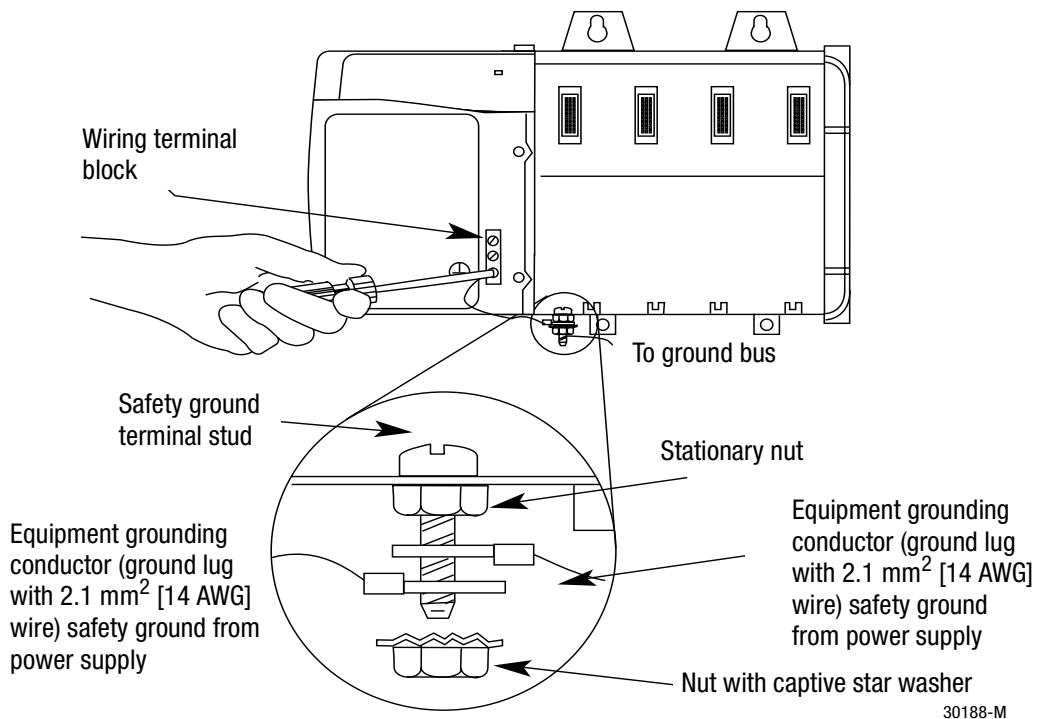

5. Use the following illustration to run functional and safety ground connections from the chassis and power supply to the ground bus.

Keep wire lengths as short as possible.

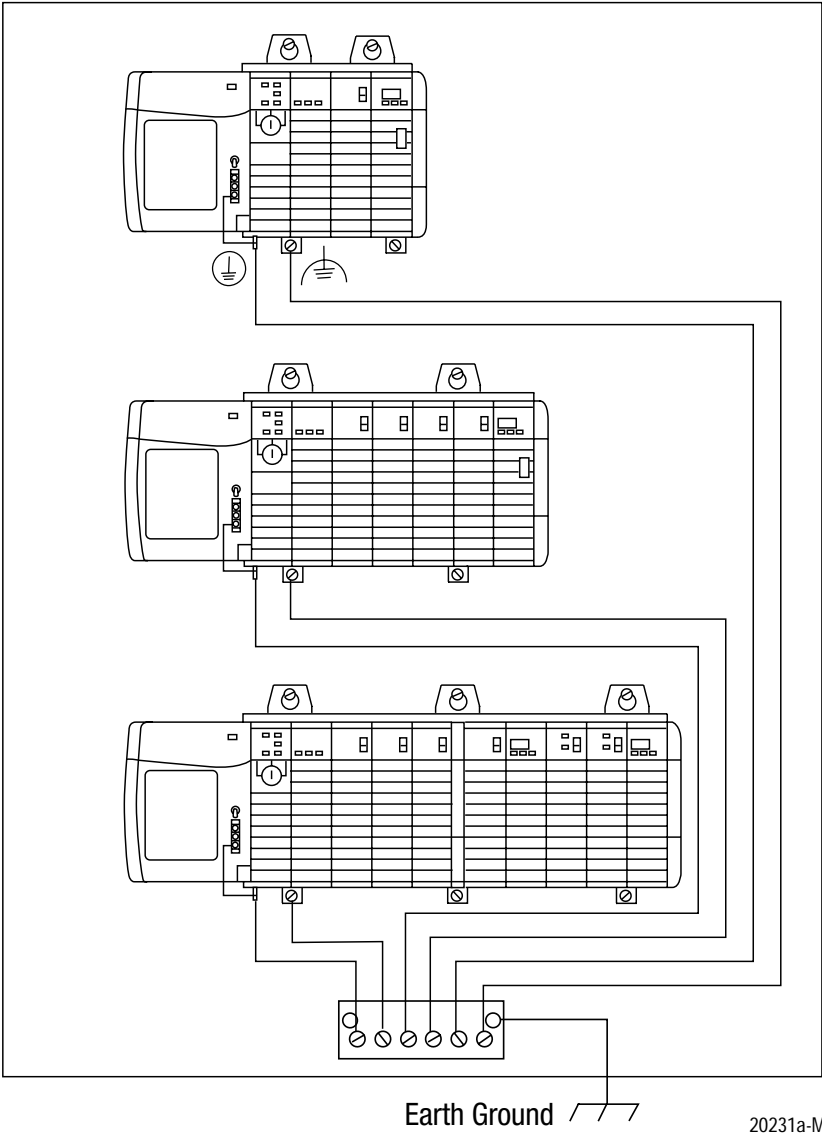

IMPORTANT

We recommend using a ground bus because it reduces the electrical resistance at the connection.

Connect Power

ATTENTION

Turn off power lines before connecting power. Failure to do so could cause injury to personnel and/or damage to equipment.

1. Use #14 AWG 75 °C copper wire.
 2. Tighten terminals to a torque of 7 inch-pounds.
 3. Connect L1 for the high side of line power.
 4. Connect L2 for the low side of line power.
1. Remove the protective label from the top of the power supply.

IMPORTANT

Make sure you mount the chassis and complete work on the panel before you remove the protective label. The label protects the power supply from metal shavings falling inside the power supply and damaging it during operation.

2. Apply power by toggling the switch on the front of the power supply from OFF to ON.

Troubleshoot the Power Supply

The ControlLogix power supply has a green LED indicator that remains on during normal operation. If the indicator is off during normal operation, try the following:

1. Verify that line voltage is within the specified range.
2. Make sure the input voltage jumper is in the proper position (see page 5).
3. If indicator remains off, cycle line power off.
4. Loosen the screws holding the power supply to the chassis.
5. Slide the power supply out so the rear connector is disconnected.
6. Wait 45 seconds and re-apply power.
7. If the indicator turns on, verify that the system module loads are within the output rating of the power supply and re-install the power supply in the chassis.
8. If the LED turns off, return the power supply to your local Rockwell Automation distributor.

Installing the ControlNet Communications Module

Install the 1756-CNB module for ControlNet communications into slot 0 of the chassis.

1. Align the module circuit board with the top and bottom guides in the chassis.
2. Slide the module into the chassis. Make sure the module properly connects to the chassis backplane.

TIP

The module is fully installed when it is flush with the power supply or other installed modules.



To remove the module, push down on the locking clips at the top and bottom of each module. Slide the module out of the chassis.

Installing the 1757-PLX52 Process Controller Module

Install the 1757-PLX52 module into slot 1, 3, 5, 7, 9, 11, 13 or 15 of the chassis.

1. Align the module circuit board with the top and bottom guides in the chassis.
2. Slide the module into the chassis in the appropriate slot. Make sure the module properly connects to the chassis backplane.

TIP

The module is fully installed when it is flush with the other installed modules.



To remove the module, push down on the locking clips at the top and bottom of each module. Slide the module out of the chassis.

Install the Battery

The battery is disconnected during shipping to conserve power. To install the battery:

ATTENTION



The 1757-PLX52 module contains a non-rechargeable lithium battery. This battery may present a risk of fire or chemical burns if mishandled. Do not recharge, disassemble, heat above 100 °C (212 °F), or incinerate. Always dispose of lithium batteries properly.

1. Open the front door of the 1752-PLX module.
2. Locate the battery connector (a small, white plug at the end of a pair of red and black twisted wires).

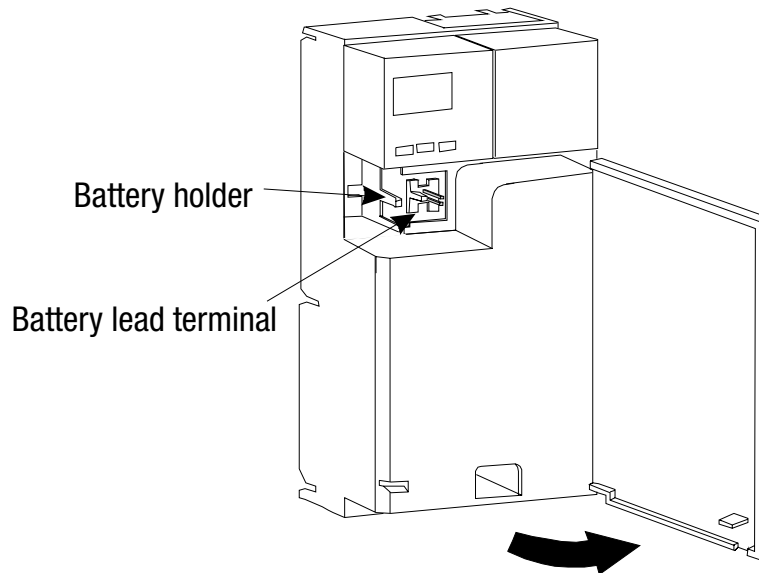

3. Align and insert the connector into the battery terminal on the module.
 - A. Turn the plug so that the wires enter the plug from the right.
 - B. Slide the plug over the two-prong male plug in the battery compartment.

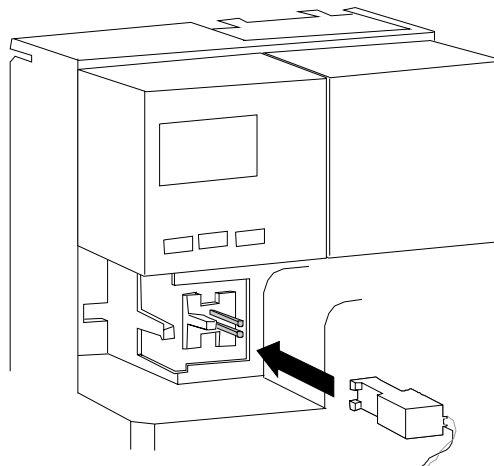

4. Slide the 1757-PLX52 module into the chassis into the first slot at the far left of the chassis.
5. Insert the end of the battery away from the lead wire into the recessed area in the module. Make sure the black retaining tab (located next to the battery lead terminal) clicks and secures the battery in its holder.

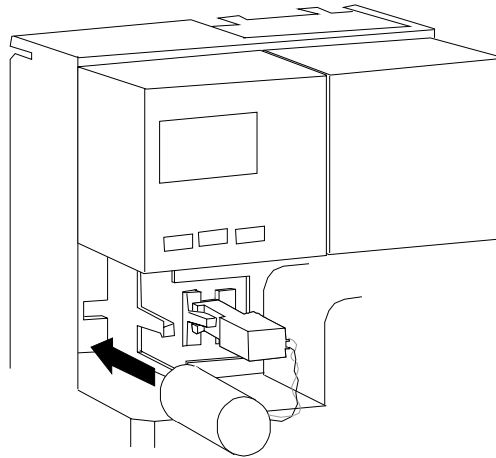

6. Close the module front door.

Installing I/O Modules

Install I/O modules in any available slot.

TIP

For information on installing I/O modules, refer to the documentation that was shipped with the module.



1. Align the module circuit board with the top and bottom guides in the chassis.
2. Slide the module into the chassis. Make sure the module properly connects to the chassis backplane.

TIP

The module is fully installed when it is flush with the other installed modules.



To remove the module, push down on the locking clips at the top and bottom of each module. Slide the module out of the chassis.

Setting up and Configuring the Server

To use the server (cat. no. 1757-PLXC) in your ProcessLogix system, you must:

- connect server hardware
- start and log in to the server
- verify RSLinx™ communication software configuration and the ControlNet server address
- verify Ethernet™ adapter and TCP/IP address

Connect Server Hardware

1. To connect the server hardware, refer to the Dell PC startup documentation that accompanied the server.
2. To install the 9904-KTCX15B card in your server, refer to the 9904-KTCX15B installation instructions that accompanied your card.
3. Once you have connected the hardware, apply power to the server, and ensure that it operates correctly.

Start and Log in to the Server

1. Apply power to the server (if you have not done so already).
2. At the login screen, type the following:

in this field	enter
User Name	administrator
Password	password

Verify RSLinx Communication Software Configuration

To communicate with ControlNet devices, your server must have:

- RSLinx communication software properly configured
- an operating KTC driver

After you have successfully logged on to your server for the first time, make sure that RSLinx communication software is properly configured, and your server has a valid address for communication with ControlNet devices. Each ControlNet device

must have a unique address. In this section, we show you how to verify that your communication software is working properly and how to find the server address.

Start RSLinx software

To start RSLinx:

1. In your Microsoft Windows NT™ desktop, select Start⇒Programs⇒Rockwell Software⇒RSLinx.

RSLinx opens in about ten seconds.

2. Select Communications⇒Configure Drivers.

Verify RSLinx communication software configuration

Once you have started RSLinx, you can verify that it has been configured correctly. When you select Communications⇒Configure Drivers in RSLinx, you see a screen that looks like this one:

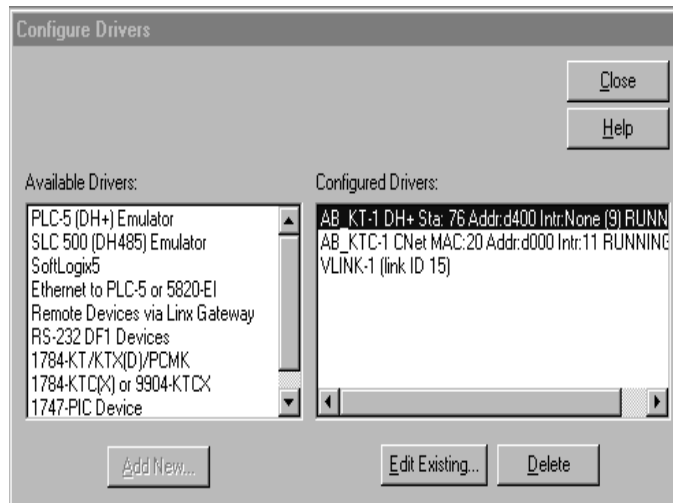

if you see this in the Configured Drivers window	then
AB_KTC-1 CNET MAC Addr:...RUNNING	RSLinx is correctly configured on your system
AB_KTC-1 CNET MAC Addr:...NOT RUNNING	RSLinx may not be configured correctly. See page 13.

*Verify and record server ControlNet address***TIP**

The ControlNet address is called the MAC ID on some screens.



1. On the RSLinx Configure Drivers screen, double-click on this line in the Configured Drivers window:

AB_KTC-1 CNET MAC Addr:...RUNNING

You see the Configure Allen-Bradley KTC(X) Device screen.



1. Verify that the ControlNet address is configured correctly. In the MAC ID field, check that the MAC ID is equal to 20.
2. Close the Configure Drivers screen.
3. To close RSLinx, select File⇒Exit.

Verify the Ethernet Adapter and TCP/IP Address

The ProcessLogix server uses Ethernet hardware and the TCP/IP protocol to communicate with client user stations. Even if your system does not have a client user station, you will need to install an adapter and configure a TCP/IP address for proper communication.

Verify the Ethernet adapter

IMPORTANT

If your server and remote stations do not have Ethernet cards installed, you can use the Microsoft loopback adapter provided with the NT operating system. The loopback adapter is a software program that emulates the operation of the Ethernet card

1. In your Microsoft Windows NT desktop, select Start⇒Settings⇒Control Panel.
2. Double-click on the Network icon. You see the Network screen.
3. Click the Adapters tab. You see the Network Adapters screen.

TIP

On this screen, adapter (1) is an Ethernet card. Adapter (2) is the loopback adapter. Your configuration may vary.



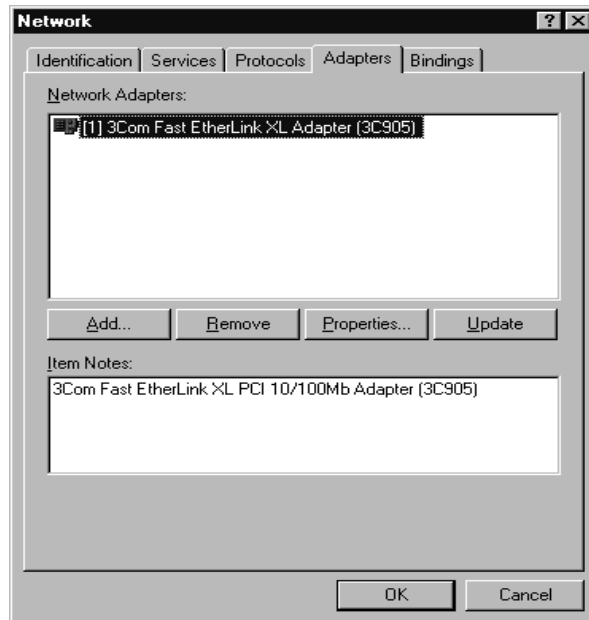

4. Verify that the configured adapter appears in the list. If it does not appear, you may need to install and configure the adapter yourself. Refer to the documentation accompanying the Ethernet card or loopback adapter for more information.

Verify the TCP/IP address

Verify the TCP/IP address *only* if your system will communicate with remote stations. Otherwise, skip this section.

1. From the Network menu, click on the Protocols tab,
2. In the Network Protocols field, double-click on **TCP/IP Protocol**.
3. On the TCP/IP Properties screen that appears, select the Ethernet adapter you have installed.

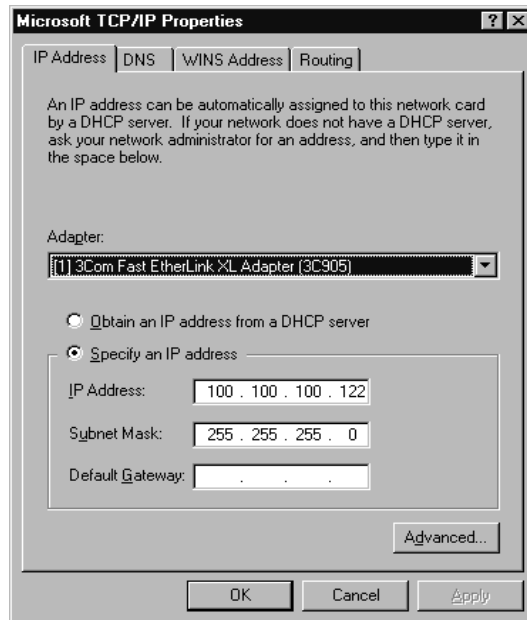

4. Write down the information that is displayed in the IP Address and Subnet Mask fields. You will need this information later when you connect other computers to your server.

IP Address: _____ Subnet Mask: _____

Depending on changes you made to your configuration, you may need to reboot your system. Shut down all applications before rebooting the system.

5. To close the TCP/IP properties screen, click on Cancel.
6. To close the network program, click Cancel.
7. To close the Windows Control Panel, select File⇒Close.

Installing ControlNet Cabling

To install the ControlNet cabling for ControlNet communications, you will need:

- two 1786-TPS or 1786-TPR droplines
- two 1786-XT termination resistors
- one 1786-BNCP cable

To install the cabling:

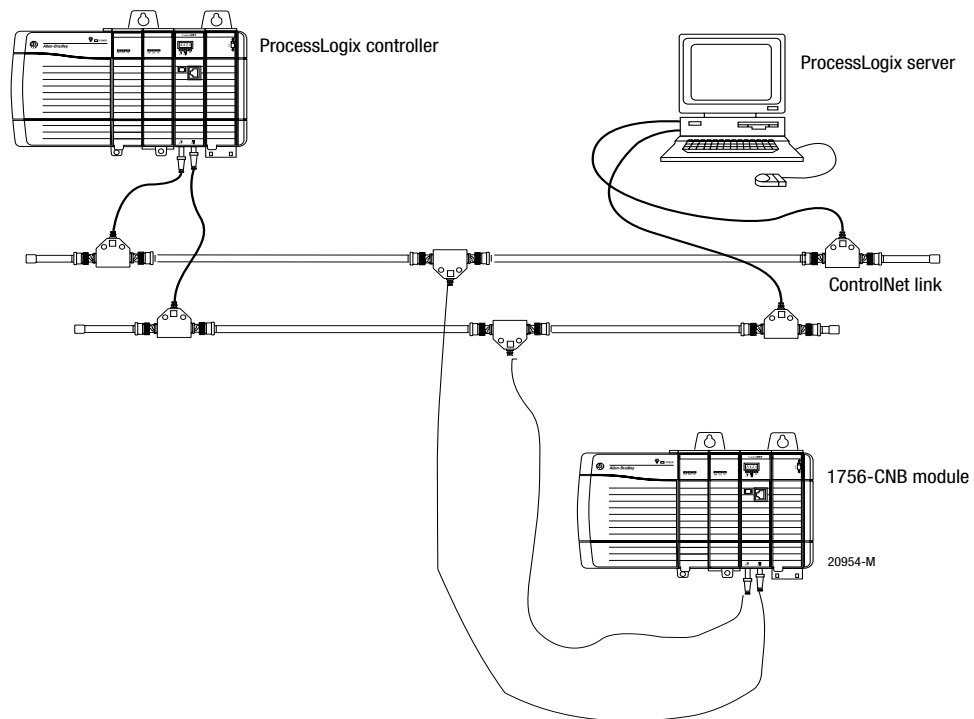

1. Connect a termination resistor on one side of each dropline.
2. Connect each dropline to a 1786-BNCP cable.
3. Connect the bottom of one dropline to the 1756-CNB module.
4. Connect the bottom of the other dropline to the 9904-KTCX15B card installed in the server.

SCSA Hazardous Location Approval

CSA certifies products for general use as well as for use in hazardous locations. Actual CSA certification is indicated the product label as shown below, and not by statements in any user documentation.

Example of the CSA certification product label:



CL I, DIV 2
GP A,B,C,D
TEMP



To comply with CSA certification for use in hazardous locations, the following information becomes a part of the product literature for this CSA-certified industrial control product.

- This equipment is suitable for use in Class I, Division 2, Groups A, B, C, D, or non-hazardous locations only.
- The products having the appropriate CSA markings (that is, Class I, Division 2, Groups A, B, D) are certified for use in other equipment where the suitability of combination (that is, application or use) is determined by the CSA or the local inspection office having jurisdiction

Due to the modular nature of a programmable control system, the product with the highest temperature rating determines the overall temperature code rating of a programmable control system in a Class I, Division 2, location. The temperature code rating is marked on the product label as shown.

Temperature code rating:



CL I, DIV 2
GP A,B,C,D
TEMP



Look for temperature code rating here.

The following warnings apply to products having CSA certification for use in hazardous locations.

: Explosion hazard--

- Substitution of components may impair suitability for Class I, Division 2.
- Do not replace components unless power has been switched off or the area is known to be non-hazardous.
- Do not disconnect equipment unless power has been switched off or the area is known to be non-hazardous.
- Do not disconnect connectors unless power has been switched off or the area is known to be non-hazardous. Secure any user-supplied connectors that mate to external circuits on this equipment by using screws, sliding latches, threaded connectors, or other means such that any connection can withstand a 15 Newton (3.4 lb.) separating force applied for a minimum of one minute.
- If the Product contains batteries, they must only be changed in an area known to be non-hazardous.

CSA logo is a registered trademark of the Canadian Standards Association.

Approbation d'utilisation dans des environnements dangereux par la

CSA

La CSA certifie des produits pour une utilisation générale aussi bien que pour une utilisation en environnements dangereux. La certification CSA en vigueur est indiquée par l'étiquette produit et non par des indications dans la documentation utilisateur.

Exemple d'étiquette de certification d'un produit par la CSA :



CL I, DIV 2
GP A,B,C,D
TEMP

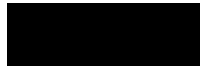

Pour satisfaire à la certification CSA en environnements dangereux, les informations suivantes font partie intégrante de la documentation des produits de commande industrielle certifiés.

- Cet équipement ne convient qu'à une utilisation dans des environnements de Classe 1, Division 2, Groupes A, B, C, D ou non dangereux.
- Les produits portant le marquage CSA approprié (c'est-à-dire Classe 1, Division 2, Groupes A, B, C, D) sont certifiés pour une utilisation avec d'autres équipements, les combinaisons d'applications et d'utilisation étant déterminées par la CSA ou le bureau local d'inspection.

De par la nature modulaire des systèmes de commande programmables, le produit ayant le code de température le plus élevé détermine le code de température global du système dans un environnement de Classe I, Division 2. Le code de température est indiqué sur l'étiquette produit.

Code de température :



CL I, DIV 2
GP A,B,C,D
TEMP



Le code de température est indiqué ici.





Les avertissements suivants s'appliquent aux produits ayant la certification CSA pour une utilisation dans des environnements dangereux.

Risque d'explosion --

- La substitution de composants peut rendre ce matériel inadapté à une utilisation en environnement de Classe 1, Division 2.
- Couper le courant ou s'assurer que l'environnement est classé non dangereux avant de remplacer des composants.
- Couper le courant ou s'assurer que l'environnement est classé non dangereux avant de débrancher l'équipement.
- Couper le courant ou s'assurer que l'environnement est classé non dangereux avant de débrancher les connecteurs. Fixer tous les connecteurs fournis par l'utilisateur pour se brancher aux circuits externes de cet appareil à l'aide de vis, loquets coulissants, connecteurs filetés ou autres, de sorte que les connexions résistent à une force de séparation de 15 Newtons (1,5 kg - 3,4 lb.) appliquée pendant au moins une minute.
- S'assurer que l'environnement est classé non dangereux avant de changer les piles.

AVERTISSEMENT :Le sigle CSA est une marque déposée de la Canadian Standards Association.

Specifications

Parameter	Operative and Storage Limits	Transportation Band
Ambient Temp Range	0 to +60°C no fans	-40 to 85°C
Temp. Rate of Change	≤ 1°C/min.	≤ 5°C/min.
Relative Humidity (non-condensing)	5 to 95%	5 to 95%
Vibration (3 axes) Frequency Acceleration Displacement	10 to 60 Hz 0.5 g max. 0.1 inches	10 to 60 Hz 1 g max. 0.1 inches
Mechanical Shock Acceleration Duration	5 g max. 30 ms max.	20 g max. 30 ms max.
Barometric Pressure Altitude	-300 to +3000 m	Any
Corrosives	G2 std, G3 option (ISA S71.04)	G3
Module Power Requirements	+5 VDC +/- 5% @ 1.5 A +3.3 VDC +/- 5% @ 1.0 A	
Module Battery Backup Time Lithium Battery (standard, built in) Battery Extension Module (1757-BEM)	144 hours (non-rechargeable, replaceable) - 6 days 120 hours (rechargeable) - 5 days	Lithium battery is disconnected during shipment.
Removal/Insertion under power (RIUP)	NOT PERMITTED when equipment is installed in a Class I, Division 2, Hazardous (Classified) Location. PERMITTED when equipment is installed in ordinary, non-hazardous, locations (I/O modules reload automatically)	
CE Conformity (Europe)	89/336/EEC, EMC Directive EN 50081-2, Emissions, Industrial EN 50082-2, Immunity, Industrial	N/A
Agency Certifications When product is marked:	 or   marked for all applicable directives  Class I Div 2 Hazardous ⁽¹⁾	

⁽¹⁾ CSA certification - Class I, Division 2, Group A,B,C,D or nonhazardous locations

Notes:

Reach us now at www.rockwellautomation.com

Wherever you need us, Rockwell Automation brings together leading brands in industrial automation including Allen-Bradley controls, Reliance Electric power transmission products, Dodge mechanical power transmission components, and Rockwell Software. Rockwell Automation's unique, flexible approach to helping customers achieve a competitive advantage is supported by thousands of authorized partners, distributors and system integrators around the world.

Americas Headquarters, 1201 South Second Street, Milwaukee, WI 53204, USA, Tel: (1) 414 382-2000, Fax: (1) 414 382-4444
European Headquarters SA/NV, avenue Herrmann Debroux, 46, 1160 Brussels, Belgium, Tel: (32) 2 663 06 00, Fax: (32) 2 663 06 40
Asia Pacific Headquarters, 27/F Citicorp Centre, 18 Whitfield Road, Causeway Bay, Hong Kong, Tel: (852) 2887 4788, Fax: (852) 2508 1846



**Rockwell
Automation**

Publication 1757-5.1 - August 1999

Supersedes Publication 1757-5.1 - May 1999

PN 957208-55

© 1999 Rockwell International Corporation. Printed in the U.S.A.