

Integrated Display Computers

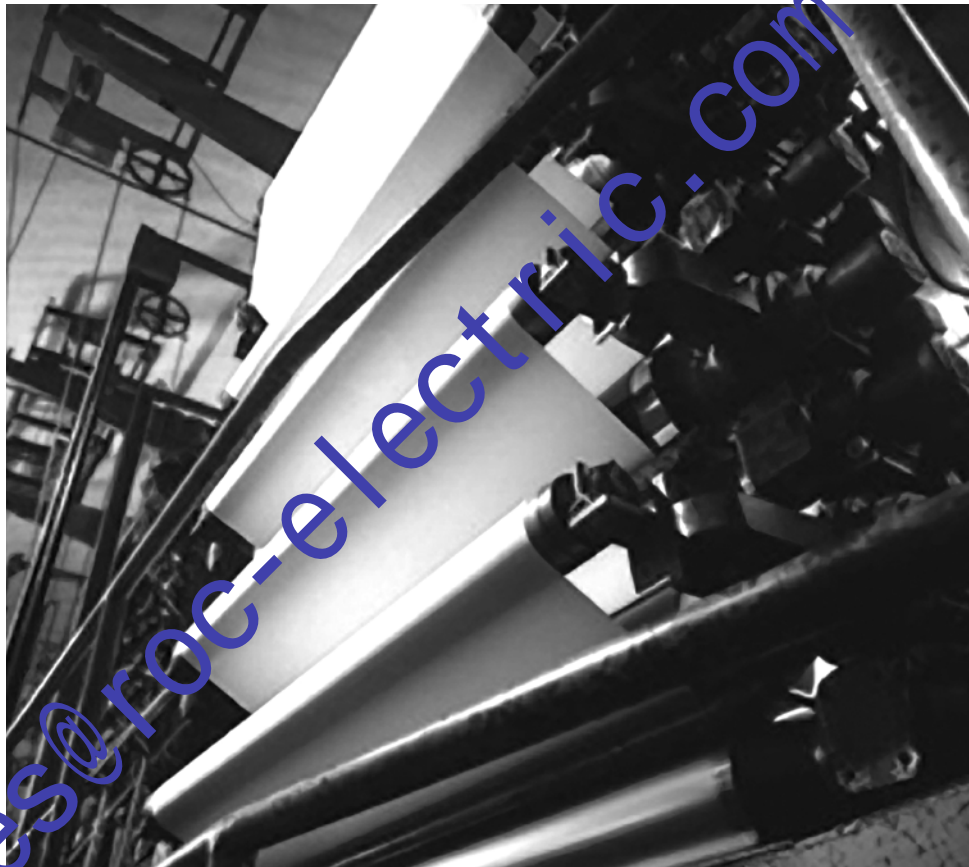

User Manual

Catalog Numbers

6181P-12NSXPH, 6181P-12NPXPH,
6181P-12TSXPH, 6181P-12TPXPH,
6181P-12TPXPHDC, 6181P-15NSXPH,
6181P-15NPXPH, 6181P-15TSXPH,
6181P-15TPXPH, 6181P-15TPXPHSS,
6181P-17NSXPH, 6181P-17NPXPH, 6181P-17TSXPH,
6181P-17TPXPH, 6181P-17TPXPHSS,
6181P-2PXPH, 6181P-2PXPH

Important User Information

Solid state equipment has operational characteristics differing from those of electromechanical equipment. Safety Guidelines for the Application, Installation and Maintenance of Solid State Controls (publication SGI-1.1 available from your local Rockwell Automation sales office or online at <http://literature.rockwellautomation.com>) describes some important differences between solid state equipment and hard-wired electromechanical devices. Because of this difference, and also because of the wide variety of uses for solid state equipment, all persons responsible for applying this equipment must satisfy themselves that each intended application of this equipment is acceptable.





In no event will Rockwell Automation, Inc. be responsible or liable for indirect or consequential damages resulting from the use or application of this equipment.

The examples and diagrams in this manual are included solely for illustrative purposes. Because of the many variables and requirements associated with any particular installation, Rockwell Automation, Inc. cannot assume responsibility or liability for actual use based on the examples and diagrams.

No patent liability is assumed by Rockwell Automation, Inc. with respect to use of information, circuit equipment, or software described in this manual.

Reproduction of the contents of this manual, in whole or in part, without written permission of Rockwell Automation, Inc., is prohibited.

Throughout this manual, when necessary, we use notes to make you aware of safety considerations.

WARNING 	Identifies information about practices or circumstances that can cause an explosion in a hazardous environment, which may lead to personal injury or death, property damage, or economic loss.
IMPORTANT	Identifies information that is critical for successful application and understanding of the product.
ATTENTION 	Identifies information about practices or circumstances that can lead to personal injury or death, property damage, or economic loss. Attentions help you identify a hazard, avoid a hazard, and recognize the consequence
SHOCK HAZARD 	Labels may be on or inside the equipment, for example, a drive or motor, to alert people that dangerous voltage may be present.
BURN HAZARD 	Labels may be on or inside the equipment, for example, a drive or motor, to alert people that surfaces may reach dangerous temperatures.

Rockwell Automation, Allen-Bradley, and TechConnect are trademarks of Rockwell Automation, Inc.

Trademarks not belonging to Rockwell Automation are property of their respective companies.

The information below summarizes the changes made to this manual since the last revision.

Revision bars, as shown in the margin, identify updated information. These are the changes for this version of the document.

Topic	Page
Added revised wording for proper grounding.	17, 27

sales@roc-electric.com

sales@roc-electric.com

	Preface	
	Intended Audience	7
	Purpose of This Manual	7
	Additional Resources	7
	Chapter 1	
System Features	Chapter Objectives	9
	Overview	9
	Product Options	10
	Accessories and Replacement Parts	10
	Operating Systems	11
	Multilingual User Interface CD Pack	11
	Features	12
	Before You Begin	14
	Chapter 2	
Installation	Chapter Objective	15
	European Union Compliance	15
	Environment and Enclosure Information	16
	Installation Considerations	17
	Mounting Clearance	18
	Panel Mounting	19
	Bench or Tabletop Mounting	21
	Product Dimensions	23
	Connect a Keyboard and Mouse	25
	Connect AC Power	26
	Connect the DC Power	27
	Connect to the Network	28
	Chapter 3	
Operation	Chapter Objective	29
	Operating Guidelines	29
	Operator Access	29
	Start the System	30
	Reset the System	30
	Install Drivers	30
	Universal Serial Bus (USB) Ports	30
	Chapter 4	
Replace System Components	Chapter Objectives	31
	Accessories and Replacement Parts	31
	Safety Precautions	31
	Electrostatic Discharge (ESD)	31
	Required Tools	32
	Remove the Back Cover	32

sales@roc-electric.com

	Install or Remove Add-In Cards	33
	Replace the Floppy Drive (1500P and 1700P)	40
	Replace the Floppy or Optical Disc Drive (1200P)	42
	Replace the Optical Disc Drive (1500P and 1700P)	45
	Add or Remove the Memory Module	47
	Chapter 5	
System Troubleshooting	Chapter Objectives	49
	Hardware Diagnostics	49
	Troubleshooting Procedure	50
	Troubleshooting Checklists	51
	Chapter 6	
Maintenance	Chapter Objectives	53
	Clean the Display	53
	Replace the Battery	54
	Backlight Assembly Disposal	55
	Ship or Transport the Product	55
	Appendix A - Specifications	
	Appendix B - Use the Touchscreen	
	Appendix C - Upgrade to a New BIOS	
	Appendix D - Solid State Drive	
Index		

sales@roc-electric.com

Read this preface to familiarize yourself with the rest of the manual. The preface covers:

- Who should use this manual
- The purpose of the manual
- Additional resources

Intended Audience

Use this manual if you are responsible for installing, using or troubleshooting the Integrated Display Computers.

Purpose of This Manual

This manual is a user guide for the Integrated Display Computers. It gives an overview of the system and describes procedures to:

- Install the computer
- Make computer connections
- Configure the computer
- Troubleshoot the computer

Additional Resources

For additional information on the 6181P, 6181F, 6181H, and 6183H computers, refer to these publications.

Resource	Description
6181P Integrated Display Computers Installation Instructions, publication 6181P-IN001 .	Provides procedures on how to install the computer and make connections to the workstation.
6181H Integrated Display Computers Installation Instructions, publication 6181H-IN001 .	Provides procedures on how to install the computer and make connections to the computer.
Cloning Utility Technical Data, publication 6000-TD001 .	Provides information on how to create and restore a backup image of your computer's hard disk drive.
1200P Integrated Display Computers, publication 6183H-IN001 .	Provides procedures on how to install the computer and make connections to the computer.

These publications are on the Accessories/Cloning CD, which ships with your computer.

You can view or download publications at <http://literature.rockwellautomation.com>. To order paper copies of technical documentation, contact your local Rockwell Automation distributor or sales representative.

sales@roc-electric.com

System Features

Chapter Objectives

This chapter provides an overview of the computers including:

- Product options
- Accessories
- Operating systems
- Features
- Accessories
- Parts List

Overview

The Integrated Display computers feature 12.1, 15, and 17-inch displays with a resistive touch screen option. When panel space is limited, the 12.1 inch model provides product information within a small space. For operations where it is important to view every aspect of a process, the 15 and 17-inch displays provide the necessary detail.

These panel-mounted computers combine an industrially hardened monitor and computer in a single machine, providing computing power for visual interface, maintenance, and basic information applications. Because there are no external monitor cables or separate component mounting requirements, system integration is simplified.

The computers provide serial and Ethernet communication ports.

Product Options

Cat. No. ⁽¹⁾	Model	Display Size	Touchscreen	Performance	Operating System
6181P-12TSXPH	1200P	12 in	Yes	Standard	Windows XP
6181P-12TPXPH			Yes	Performance	
6181P-12NSXPH			No	Standard	
6181P-12NPXPH			No	Performance	
6181P-2PXPH		No	No	Performance	
6181F-15TPXPH	1500P	15 in	Yes	Performance	Windows XP for Embedded Systems
6181P-15TSXPH			Yes	Standard	Windows XP
6181P-15TPXPH			Yes	Performance	
6181P-15TPXPHSS ⁽²⁾			No	Standard	
6181P-15NSXPH			No	Performance	
6181P-15NPXPH			Yes	Standard	
6181H-15TSXPH			No	Performance	
6181P-17NP2KH	1700P	17 in	No	Performance	Windows XP
6181P-17TSXPH			Yes	Standard	
6181P-17TPXPH			Yes	Performance	
6181P-17TPXPHSS ⁽²⁾			No	Standard	
6181P-17NSXPH			No	Performance	
6181P-17NPXPH			No	Performance	

⁽¹⁾ The computers are available with the Windows XP or Windows 2000 operating system. Replace XP with 2K in the catalog number to order a computer with Windows 2000.

⁽²⁾ Catalog numbers ending in SS have a stainless steel bezel.

Accessories and Replacement Parts

You can view a current list of accessories at the Rockwell Automation Allen-Bradley website <http://www.ab.com/industrialcomputers>.

Operating Systems

The computers are shipped with one of these operating systems:

- Windows 2000 Professional, Service Pack 4 with Update Rollup 1
- Windows XP Professional, Service Pack 2b

No operating system updates have been applied to the factory image beyond the service packs.

For your convenience, the I386 source directory for Microsoft Windows is on the system drive of your computer off the root directory, C:\I386. This allows for easy removal and addition of Windows components.

Computers with rotating-media hard drives include a recovery partition on the system drive containing the original factory image. You can use the supplied System Accessories/Cloning CD to restore the operating system from the recovery partition, create a new recovery image, and create bootable external recovery media.

Refer to the Cloning Utility documentation, publication [6000-TD001](#), for instructions. You can view or download publications at <http://literature.rockwellautomation.com>.

Computers with solid state drives have been customized to accommodate the unique properties of the solid state drive. Some of the pre-installed customizations include:

- no paging file.
- system restore set to zero and disabled.
- DLLCACHE directory emptied.

Computers with solid state hard drives do not contain a recovery partition. If additional drive space is required, copy the I386 directory to external media; then delete the I386 directory from C:\I386, which is approximately 400 MB.

To obtain the original factory image on bootable external recovery media, which also includes the I386 source directory, contact your local technical support center.

Multilingual User Interface CD Pack

The Microsoft Multilingual User Interface (MUI) CD Pack contains a collection of different language sets that can be installed into the operating system. MUI packs are available for all Windows XP operating systems and provide a localized start menu and system icons support.

The instructions for installing MUI languages on your computer are supplied with the MUI CD Pack.

Features

The illustrations show the major features and controls of the computers.

Top and Side View

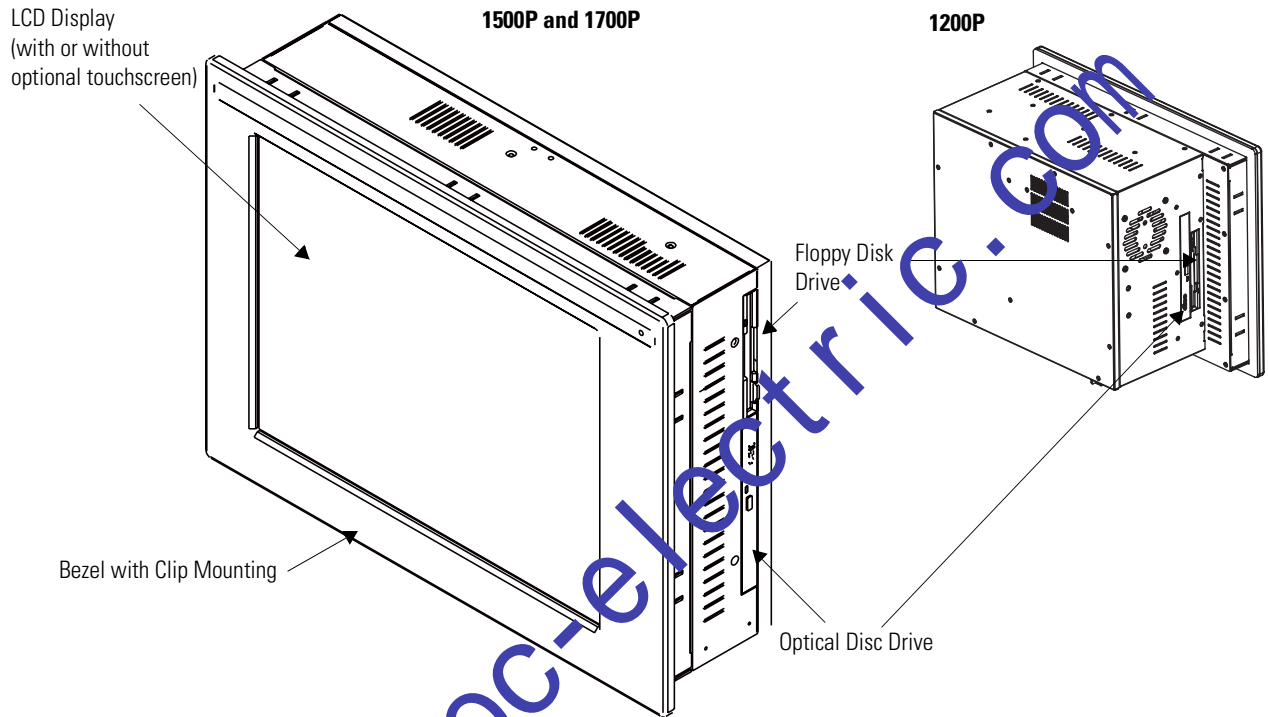

Bottom View

1200P

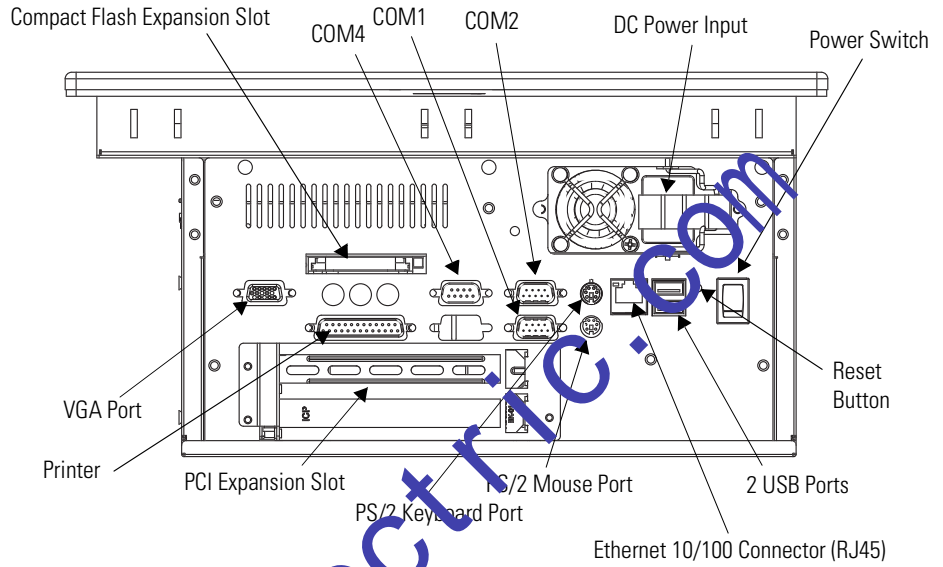

1500P and 1700P Series A

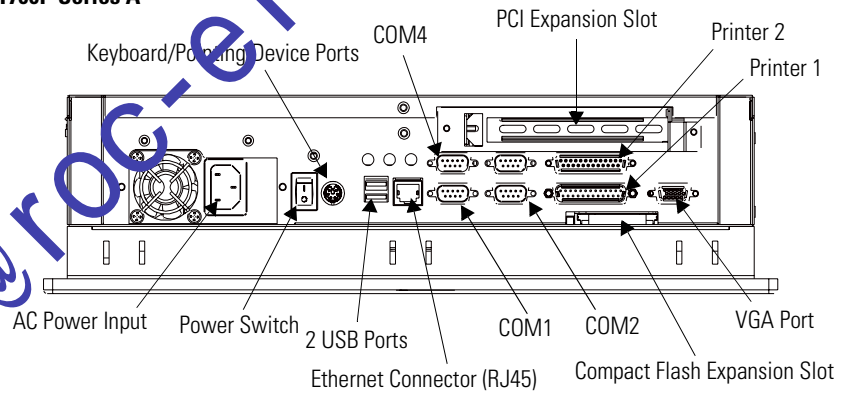

1500P and 1700P Series B

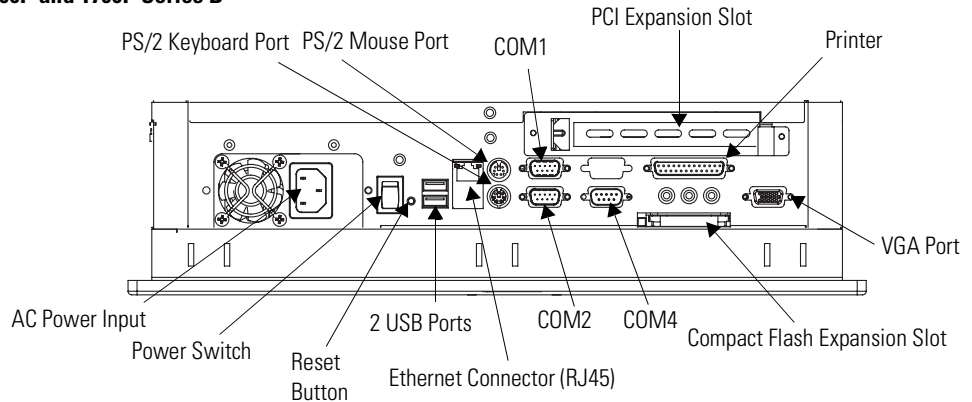

Before You Begin

Before unpacking the product, inspect the shipping carton for damage. If damage is visible, immediately contact the shipper and request assistance. Otherwise, proceed with unpacking.

Keep the original packing material in case you need to return the product for repair or transport it to another location. Use both the inner and outer packing cartons to ensure adequate protection for a unit returned for service.

Parts List

Your computer ships with these items:

- System Accessories/Cloning CD
- Support CD
- Microsoft Multilingual User Interface (MUI) CD Pack
This CD pack is not included with computers containing solid-state hard drive or computers with the Windows 2000 operating system.
- Mounting clips, except for the 1200P Non-display computer
- Power cord, AC (when appropriate)
- PS/2 Y-adapter cable for keyboard and mouse connection (supplied with all 6181P Series A and 6181H 1500P Series B computers)
- Installation guide and cutout template

Sales@roc-electric.com

Installation

Chapter Objective

This chapter describes how to install your computer in a panel and how to make connections. It covers the following topics:

- European Union Directive Compliance
- Environment and enclosures
- Installation considerations
- Mounting clearances
- Mounting the computer in a panel
- Mounting the computer on a bench or tabletop
- Product dimensions
- Connect a keyboard or mouse
- Connect AC or DC power
- Connect to a network

European Union Compliance

This product meets the European Union Directive requirements when installed within the European Union or EEA regions and has the CE mark. A copy of the Declaration of Conformity is available at the Rockwell Automation / Allen-Bradley website: www.ab.com/certification.

ATTENTION

This product is intended to operate in an industrial or control room environment, which utilizes some form of power isolation from the public low voltage mains. Some computer configurations may not comply with the EN 61000-3-2 Harmonic Emissions standard as specified by the EMC Directive of the European Union. Obtain permission from the local power authority before connecting any computer configuration that draws more than 75 watts of AC power directly from the public mains.

ATTENTION

To comply with EN 55024, the Ethernet port LAN cable must be less than 30 m (98.42 ft) long, and it must only be used indoors (i.e., not exit the building at any point). All other I/O cables must be less than 3 m (9.842 ft) long, and must only be used indoors.

Environment and Enclosure Information

Review the information on enclosures and environments before installing the product.

ATTENTION



Environment and Enclosure

This equipment is intended for use in a Pollution Degree 2 industrial environment, in overvoltage Category II applications (as defined in IEC publication 60664-1), at altitudes up to 2000 meters (6562 feet) without derating.

This equipment is considered Group 1, Class A industrial equipment according to IEC/CISPR Publication 11. Without appropriate precautions, there may be potential difficulties ensuring electromagnetic compatibility in other environments due to conducted as well as radiated disturbance.

Operating the capacitive touch screen version in a high noise environment may cause the touchscreen to respond slowly to touch inputs, or may cause the position of the screen cursor to drift.

This equipment is supplied as 'open type' equipment. UL recognized and hazardous location equipment must be mounted in an enclosure that is suitably designed or rated for those specific environmental conditions that will be present, and designed to prevent personal injury resulting from accessibility to live parts. UL Listed equipment need not be mounted inside another enclosure in ordinary (non-hazardous) locations if NEMA Type and IEC ratings are not required, but the mounting method must limit the tilt of the product to +/- 30° from vertical. Examples include articulated arm, table-top stand, or other means having sufficient mechanical stability. The mounting means must be firmly attached to the supporting surface using screws, bolts, or clamps so the product cannot tip. These units ship with a gasketed bezel to meet specified NEMA and IEC ratings only when mounted in a panel or enclosure with an equivalent rating. Subsequent sections of this publication may contain additional information regarding specific enclosure type ratings required to comply with certain product safety certifications.

In addition to this publication, see:

- Industrial Automation Wiring and Grounding Guidelines, for additional installation requirements, Allen-Bradley publication 1770-4.1.
- NEMA Standards publication 250 and IEC publication 60529, as applicable, for explanations of the degrees of protection provided by different types of enclosure.

Installation Considerations

Follow these guidelines to make sure your product provides safe and reliable service.

- The installation site must have sufficient power.

ATTENTION

To maintain an electrically safe installation, the product must be connected to Earth ground when installed. Follow the appropriate grounding requirements associated with your specific product type as described in this installation document.

-
- The enclosure must have sufficient space around air inlets and outlets to provide the circulation necessary for cooling. Never let air passages to become obstructed.
 - The ambient air temperature must not exceed the maximum operating temperature. Consider heat produced by other devices in the enclosure. You may need to provide a fan, heat exchanger, or air conditioner to meet this condition.

TIP

Hot air rises. The temperature at the top of the enclosure is often higher than the temperature in other parts of the enclosure, especially if air is not circulating.

IMPORTANT

The product can operate at a range of extremes. However, the life span of any electronic device is shortened if you continuously operate the product at its highest rated temperature.

-
- The humidity of the ambient air must not exceed specified limits. In very dry environments, static charges build up readily. Proper grounding of the equipment through the AC power cord helps to reduce static discharges, which may cause shocks and damage electronic components.
 - The enclosure or cover must remain in place at all times during operation. The cover provides protection against high voltages inside the product and inhibits radio-frequency emissions that might interfere with other equipment.

Mounting Clearances

Allow adequate space around the computer for mounting, air flow, connections, and maintenance. Do not operate the computer in an enclosure by using the minimum clearances unless adequate ventilation or other cooling methods are used to lower the temperature within the enclosure.

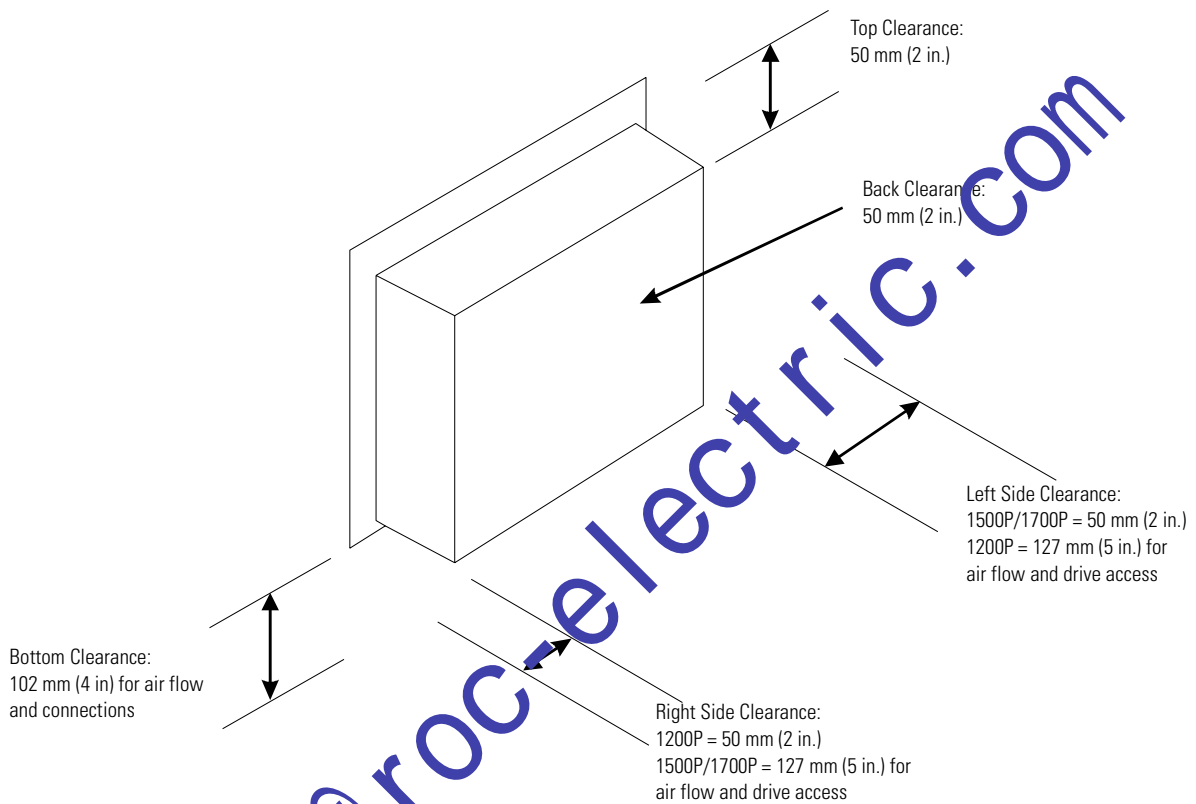

Panel Mounting

Install the computers by using mounting clips. Before installation, review:

- Tools required.
- Panel mounting guidelines.
- Panel cutout dimensions.
- Product dimensions.

Tools Required

The following tools are required for product installation:

- Panel cutout tools
- #2 Phillips screwdriver

Mounting Guidelines

Observe these guidelines when installing the unit in a panel.

- Confirm that there is adequate space behind the panel. A cabinet with a minimum depth of 127 mm (5.0 in.) is sufficient.
- Cut supporting panels to specifications before installation. Take precautions so metal cuttings do not enter components already installed in panel.
- Supporting panels must be at least 14 gauge to ensure proper sealing against water and dust and to provide proper support. The mounting hardware supplied accommodates panels up to 6.25 mm (0.25 in.) thick.

ATTENTION



Failure to follow these guidelines may result in personal injury or damage to the panel components.

Panel Cutout Dimensions

Computer Model	Cutout Dimensions (HxW)
1200P	254.0 x 324.0 mm (10.0 x 12.76 in.)
1500P	285.0 x 386.6 mm (11.24 x 15.22 in.)
1700P	329.5 x 424.0 mm (12.97 x 16.69 in.)

Mount the Computer in a Panel

Mounting clips secure the computer to the panel.

ATTENTION



Remove all electrical power from the panel before making cutout.

Make sure the area around the panel cutout is clear.

Take precautions so metal cuttings do not enter components already installed in panel.

Failure to follow these warnings may result in personal injury or damage to the panel components.

Follow these steps to mount the computer in a panel.

1. Remove power from the panel.
2. Cut an opening in the panel using the appropriate panel cutout dimensions.
3. Make sure the sealing gasket is properly positioned on the computer.

This gasket forms a compression type seal. Do not use sealing compounds.

4. Place the computer in the panel cutout.
5. Slide the mounting clips into the slots on the top, bottom, and sides of the computer.

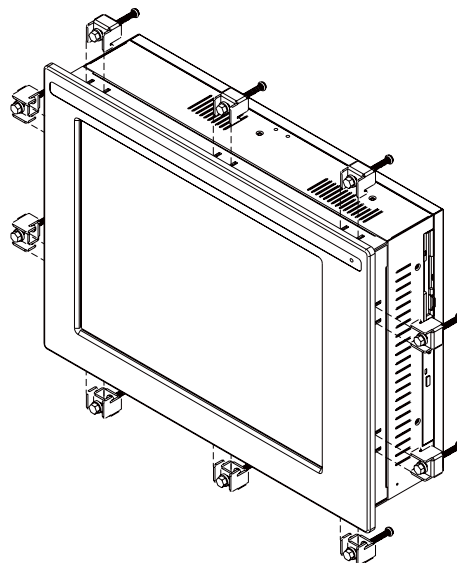

6. Gradually tighten the clips, one at a time, around the bezel by using the specified sequence.

The sequence begins with the center clips and continues to the corner clips. Repeat this process at least three times until the clips are hand-tight and the gasket is compressed uniformly against the panel.

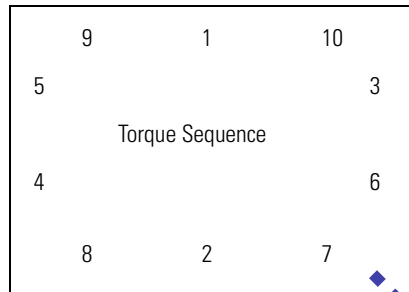

7. Tighten the mounting clips to a torque of 1.4 Nm (12 lb-in) by using the sequence in step 6.

Do not overtighten.

ATTENTION



Tighten the mounting clips to the specified torque to provide a proper seal and prevent damage to the product. Rockwell Automation assumes no responsibility for water or chemical damage to the product or other equipment within the enclosure because of improper installation.

Bench or Tabletop Mounting

You can mount the 1500P or 1700P computer on a benchtop or tabletop arm by using an optional adapter. The back of the computer has four mounting points that are VESA 100 mm standard.

Cat. No.	Description
6189V-MBA	Bench/tabletop adapter for 1500P and 1700P

Mounting Guidelines

Observe these guidelines when installing the computer on an arm:

- The mounting surface must be strong enough to support both the computer and the mounting hardware.
- The mounting arm must be strong enough to support the computer. The arm must meet VESA FPMPMI 100 mm standards.
- The mounting location must provide clearance for mounting and positioning the adjustable unit and routing cables.
- Per UL Listing restrictions, the product must be mounted with a tilt of +/- 30° or less from vertical.

Mount the Computer on a Bench or Tabletop

1. Mount the arm to the benchtop or tabletop using screws, bolts, or clamps so the computer cannot tip.
2. Place the computer over the arm, and insert four M4 x 0.7 screws through the arm brackets and into the back cover of the computer.
3. Tighten the screws.

Sales@roc-electric.com

Product Dimensions

Product dimensions for each version of the computer are given in Dimensions are mm (in.).

1200P Integrated Display Computer

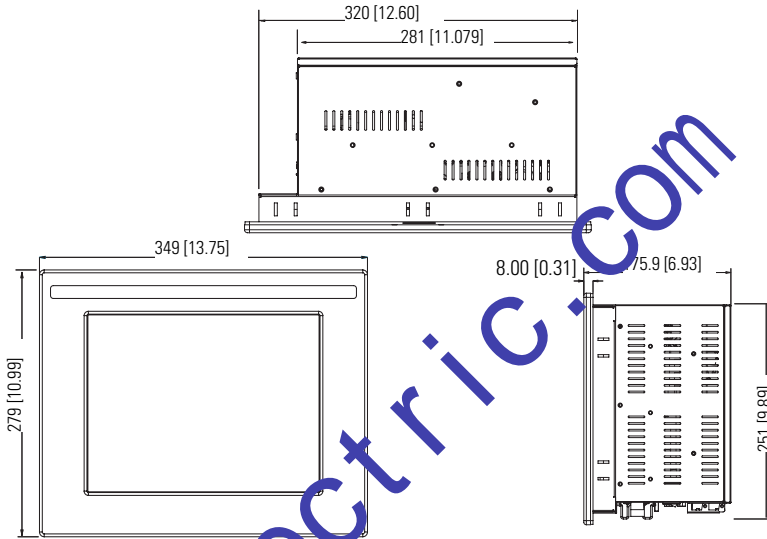

1200P Non-Display Computer

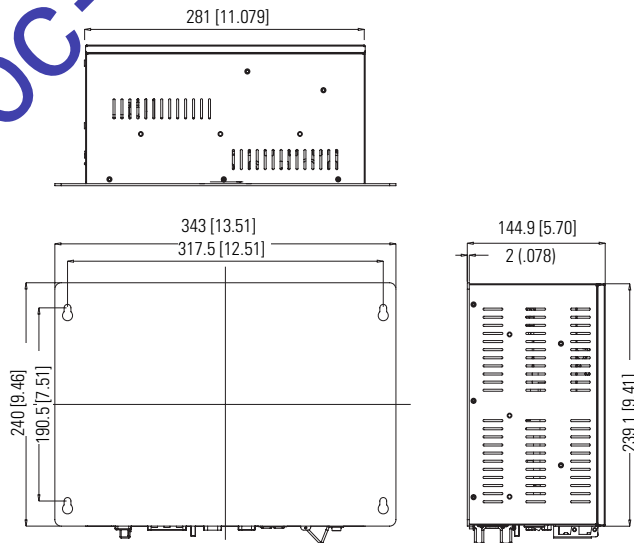

1500P Integrated Display Computer

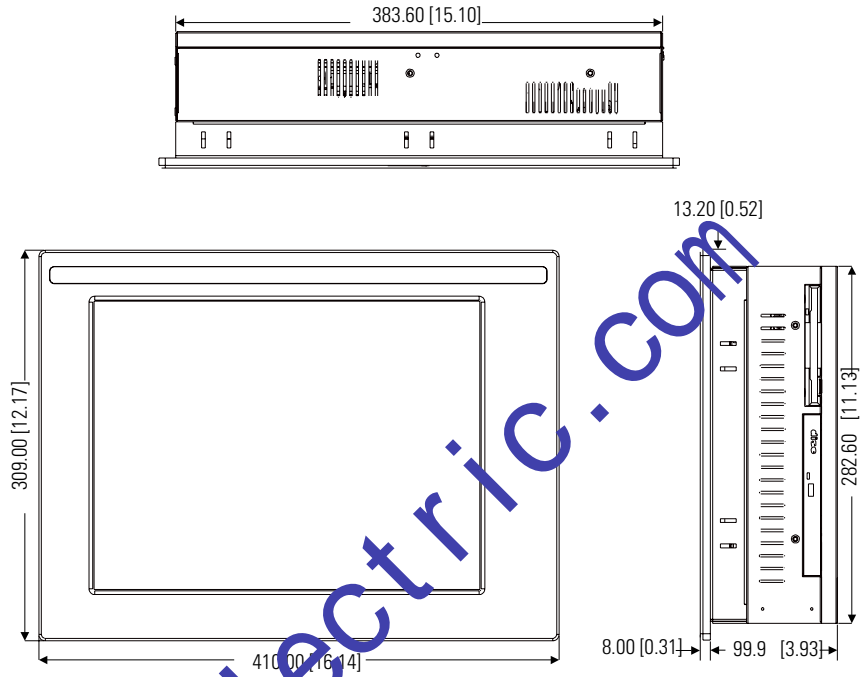

1700P Integrated Display Computer

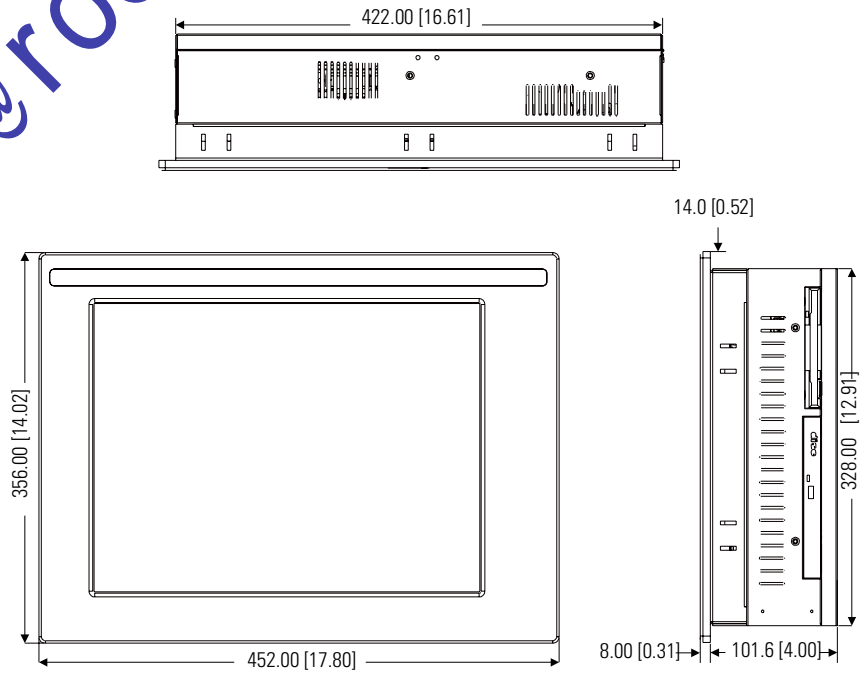

Connect a Keyboard and Mouse

You can connect a keyboard to the PS/2 port on the bottom of the computer. You can connect both a keyboard and mouse to this port by using the Y-adapter cable that ships with the 6181P Series A computers.

The 6181P Series B computers have separate PS/2 ports for the keyboard and mouse.

1500P - Series A
 1500P - 6181H Series A and B
 1700P - Series A

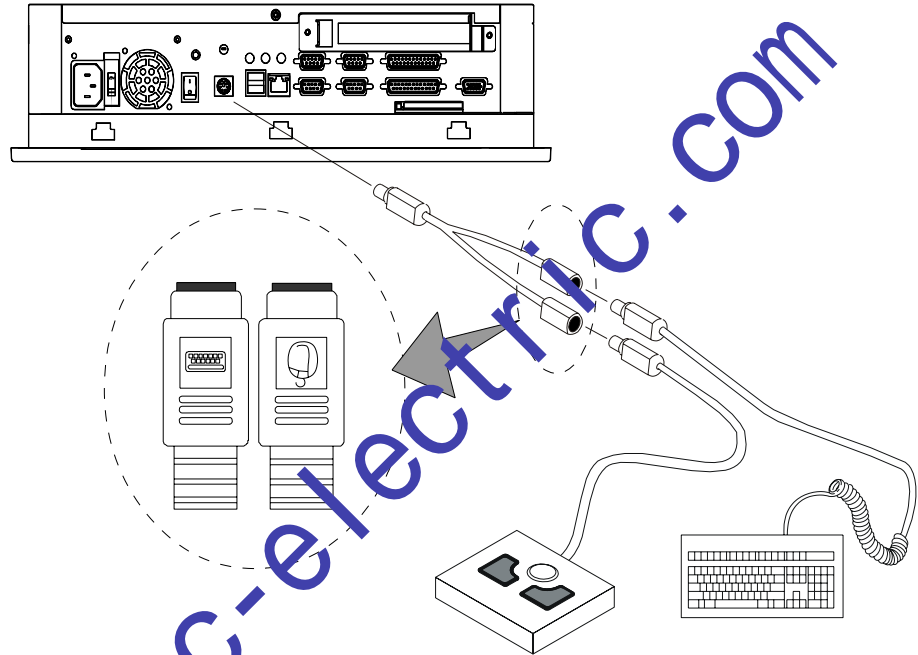

1200P - Series B and C
 1500P - Series B and C
 1700P - Series B and C

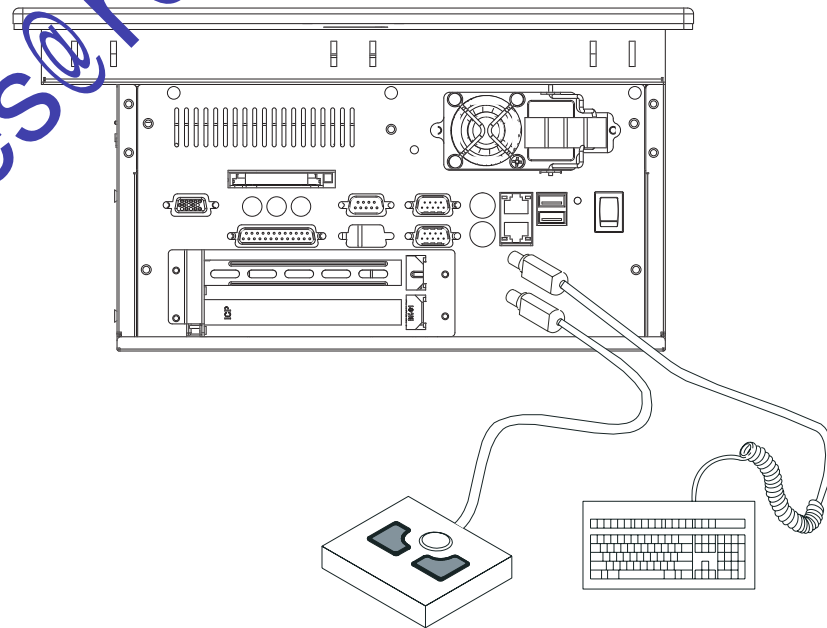

sales@roc-electric.com

Connect AC Power

A standard IEC 320 power cord provides power to the computer. The power supply input accepts 120/240V ac. The power supply is autoswitching.

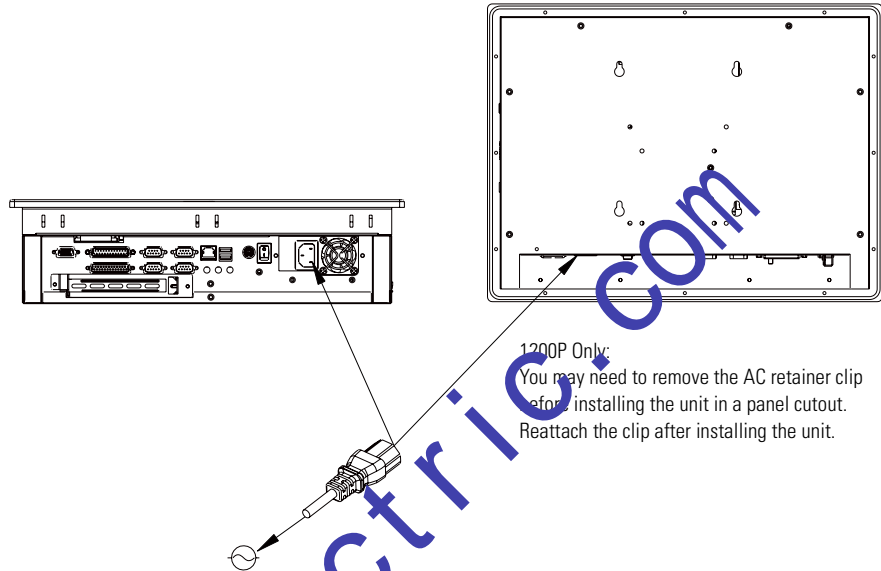

ATTENTION

Connect the AC power cord to a power source with an earth ground to prevent electrical shock. Failure to follow this warning could result in electrical shock.

The computer circuit should have its own disconnect. Use an uninterruptible power source (UPS) to protect against unexpected power failure or power surges.

Always shut down the operating system before removing power to minimize performance degradation and operating system failures.

Connect the DC Power

The 1200P computers with an integrated 24V DC power supply support these electrical ratings:

- 18 to 32V DC (24V DC nominal)
- 6.3 A at 24V DC

The power supply is internally protected against reverse polarity.

ATTENTION



Use a Class 2/SELV (Safety Extra-Low Voltage) isolated and ungrounded power supply as input power to the computer. This power source provides protection so that under normal and single fault conditions, the voltage between the conductors and Functional Earth/Protective Earth does not exceed a safe value.

To connect DC power follow these steps:

1. Secure the DC power wires to the terminal block screws.
2. Secure the ground wire to the GND terminal block screw.
3. Apply 24V DC power to the computer.

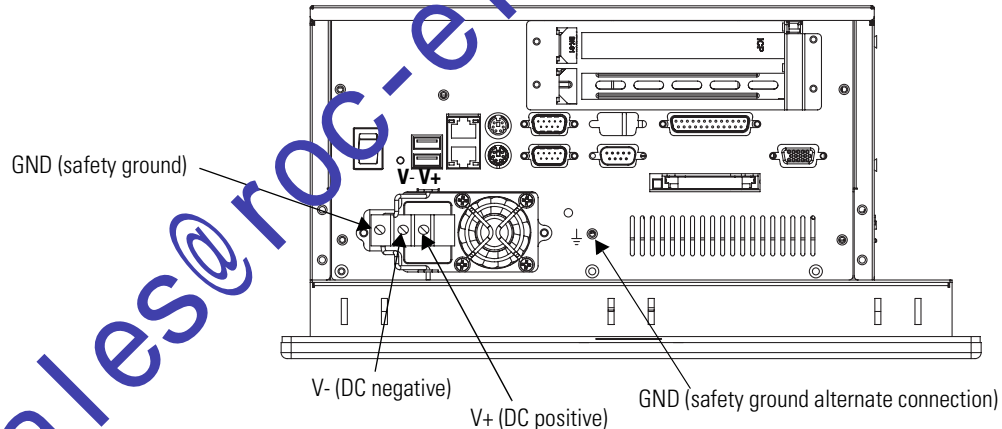

ATTENTION



Connect the product to earth ground using a 1.31 mm² (16 AWG) or larger external wire.

The ground wire should have green insulation with a yellow stripe for easy identification.

Connect to the Network

The computers connect to the Ethernet network using CAT5 or CAT5E twisted pair Ethernet cabling with RJ45 connectors. The computers support 10/100 Mbps network communication.

IMPORTANT

To prevent performance degradation of Ethernet communication, do not subject the computer or cables to extreme radiated or conducted high-frequency noise.

Proper cable routing and power conditioning is required to ensure reliable Ethernet communication in industrial environments. Rockwell Automation recommends that you route all Ethernet cabling through dedicated metal conduits. Installing ferrite bead filters at cable ends may also improve reliability.

Sales@roc-electric.com

Operation

Chapter Objective

This chapter covers the following topics:

- General operating guidelines
- Operator access to computer
- Booting the system
- Resetting the system
- Installing drivers
- Universal serial bus (USB) ports

Operating Guidelines

Follow these operating guidelines for your computer.

- Avoid turning the system on and off frequently.
- Always use the proper power down procedures as required by your operating system, such as the Shut Down command in Microsoft Windows. Failure to do so can result in performance degradation and eventual system damage.
- Do not operate the computer with the covers removed. An electrical shock hazard exists. Removing the covers will disrupt air flow and may result in overheating. All covers are required to maintain EMI shield.
- To avoid dust and other airborne contamination infiltrating the product when mounted in a suitable enclosure, the door to the enclosure must be closed at all times during operation. The door should be open for routine maintenance only.

ATTENTION

After shutting the system off, do not move the computer, or turn it back on again, until the hard drive comes to a complete stop, which takes about 30 seconds.

Operator Access

Operator access is limited to the front panel of the computer. This includes the display and touchscreen. Access to components behind the panel in which the computer is installed is restricted to authorized and properly trained personnel.

Start the System

Apply power to the system. The computer performs a Power On Self Test (POST). The processor board, memory, keyboard, and certain peripheral devices are tested.

The system displays the progress of the POST and initialization of accessory devices. The computer displays the startup dialogs for the operating system that is installed.

If your system does not boot up, or you notice other problems, refer to the System Troubleshooting chapter.

Reset the System

To reset the computer, press Ctrl+Alt+Delete on the attached keyboard and follow the operating system instructions.

After resetting, the computer begins the Power On Self Test (POST). During a reset, the computer:

- clears RAM.
- starts the POST.
- initializes peripheral devices, such as drives and printers.
- loads the operating system (if installed).

Install Drivers

The operating system usually selects the best device driver settings. However, you may want to ensure fully optimized performance by manually installing the device drivers included with your system. Refer to the Readme files on the supplied accessory CD for details on the latest device drivers and installation procedures.

Universal Serial Bus (USB) Ports

The Universal Serial Bus (USB) is an external bus standard that supports data transfer rates up to 480 Mbps (480 million bits per second). You can connect multiple peripheral devices to the USB ports, such as a mouse, modem, and keyboard. USB also supports Plug-and-Play installation and hot plugging.

For information on installing or using USB, refer to the documentation for your USB peripheral device.

TIP

Many USB devices only work with Windows XP or Windows 2000, because these operating systems have native USB drivers. Make sure the selected USB peripheral has software drivers available for your target operating system.

Replace System Components

Chapter Objectives

This chapter provides safety precautions and procedures to:

- remove the back cover.
- required tools.
- install or remove add-in cards using the PCI Expansion Kit (6189V-2PCI15).
- replace the floppy drive (1500P and 1700P).
- replace the floppy or optical disc drive (1200P).
- replace the optical disk drive (1500P and 1700P).
- replace the memory modules.

Accessories and Replacement Parts

You can view a current list of accessories at the Rockwell Automation Allen-Bradley website <http://www.ab.com/industrialcomputers>.

Safety Precautions

The computers contain line voltages. Disconnect all power to the computer before you install or remove system components.

ATTENTION

Disconnect all power from the computer before removing components. Failure to disconnect power could result in severe electrical shock or damage to the computer.

Electrostatic Discharge (ESD)

ATTENTION

Electrostatic discharge (ESD) can damage the computer and components. Make sure you work in a static-safe environment and wear a grounding strap whenever handling circuit boards, power supply, memory modules or other internal components.

Required Tools

Use a #2 Phillips screwdriver for all screws. Using the wrong size tool may cause damage to the screw head.

Remove the Back Cover

To maintain, install, or upgrade computer components, you must first remove the cover.

ATTENTION

Failure to follow proper safety precautions could result in severe electrical shock and/or damage to the computer.



Follow these steps to remove the back cover.

1. Disconnect power from the computer.
2. Remove the screws that secure the back cover.
3. Lift the cover from the chassis.

1200P

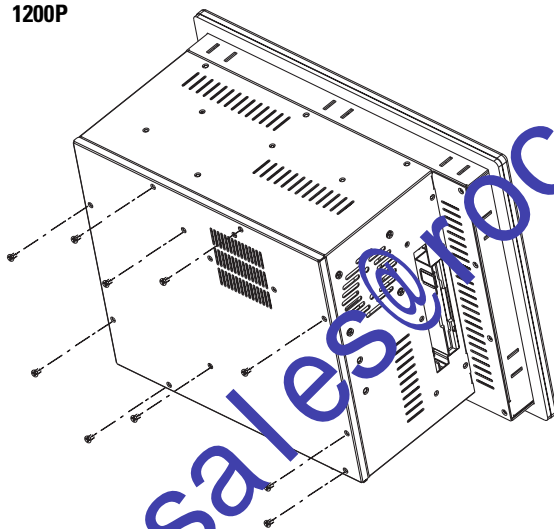

1500P, 1700P

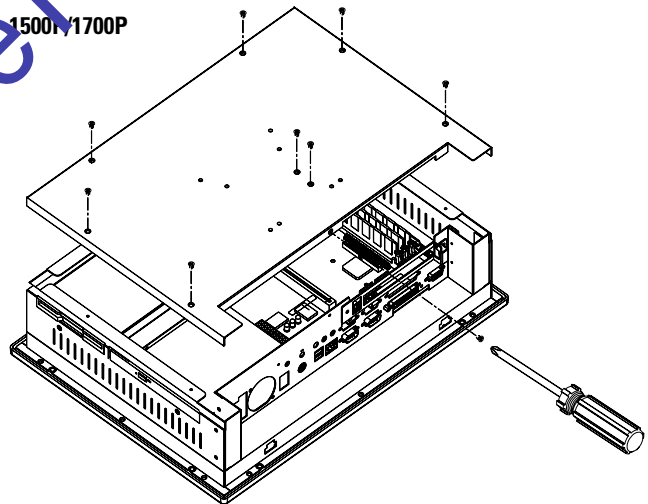

4. To reinstall the back cover, position the back cover over the chassis and fasten with the screws.

Install or Remove Add-In Cards

You can install PCI-compatible cards in the computer's PCI slot. This section shows how to install and remove cards using the PCI Expansion Slot Kit (6189V-2PCI15).

IMPORTANT

The PCI Expansion Slot Kit is not required if you are installing only one PCI card. The procedure to install one card is similar.

ATTENTION

Failure to follow proper safety precautions could result in severe electrical shock and/or damage to the computer.

**ATTENTION**

Add-in cards are sensitive to ESD and require careful handling. Hold cards only by the edges. Do not touch connectors, components, or circuits. After removing a card, place it on a flat, static-free surface, component side up. Do not slide the card over any surface.



Install an Add-in Card

Follow these steps to install an add-in card.

1. Disconnect power from the computer.
2. Remove the back cover.
3. Remove the slot cover bracket (two screws).

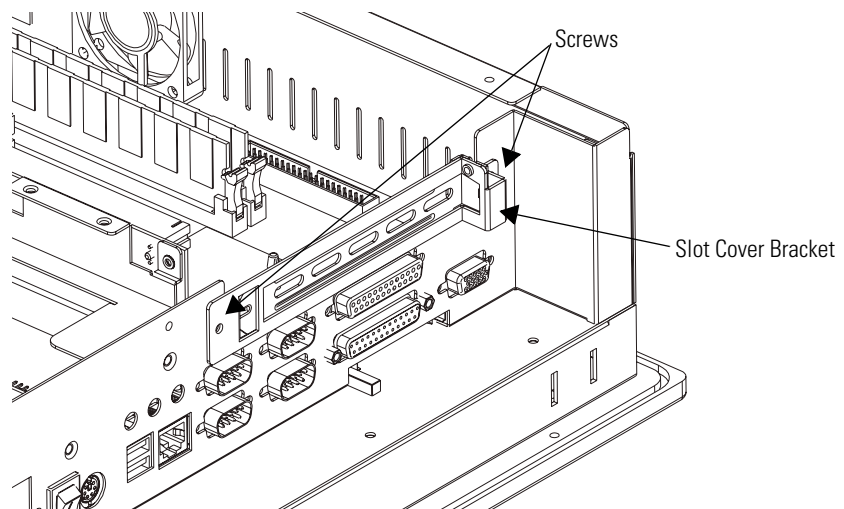

4. Remove the one-slot riser board (two screws).

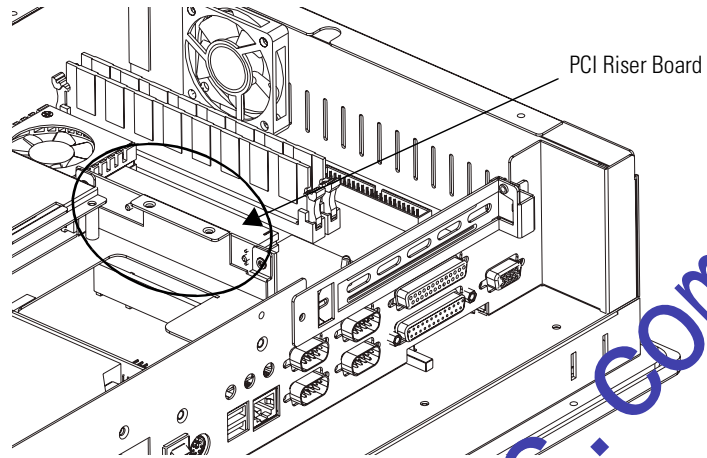

5. Add riser bracket (A) to the chassis by using six, M3x6 panhead screws.

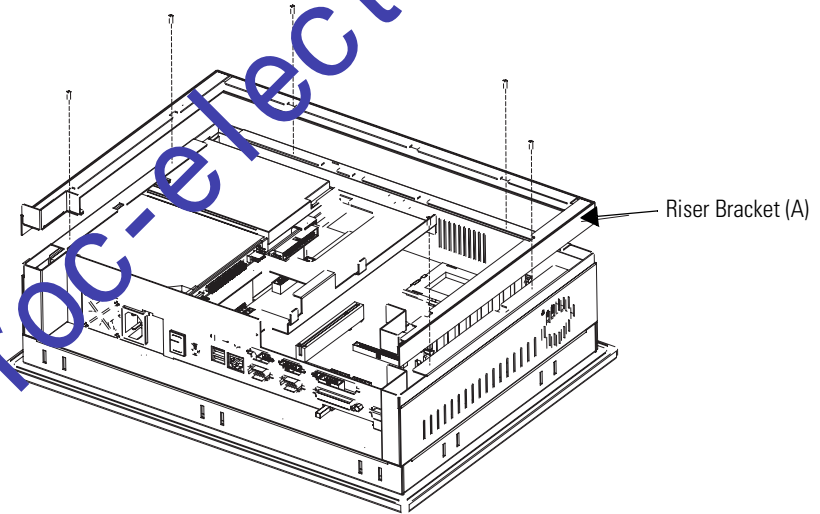

6. Add riser bracket (B) to riser bracket (A) by using seven, M3x6 flat head screws.

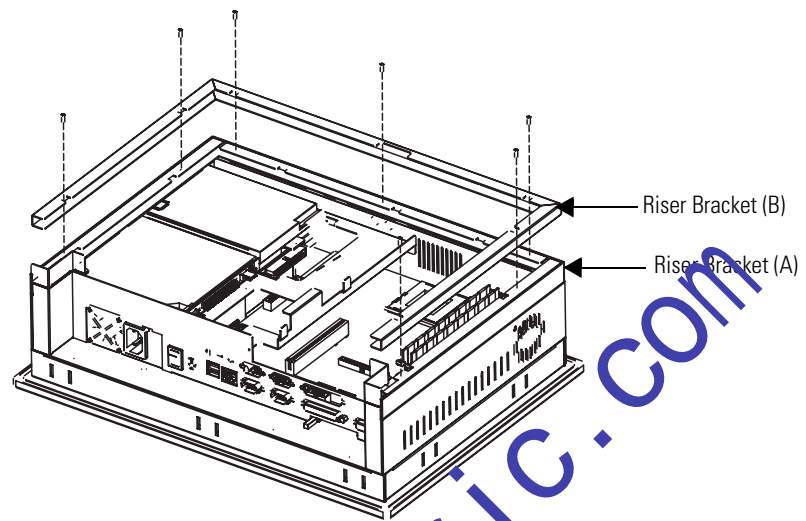

7. Add the center support to the chassis by using three screws (two - M3x6 flat head, one - M3x6 pan head).

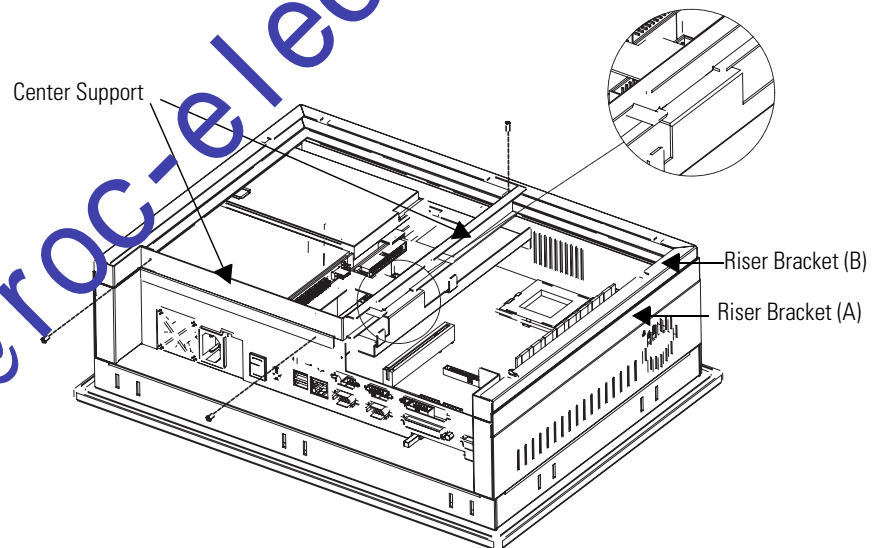

sales@roc-electric.com

8. Add the riser board using the two screws from step 4.

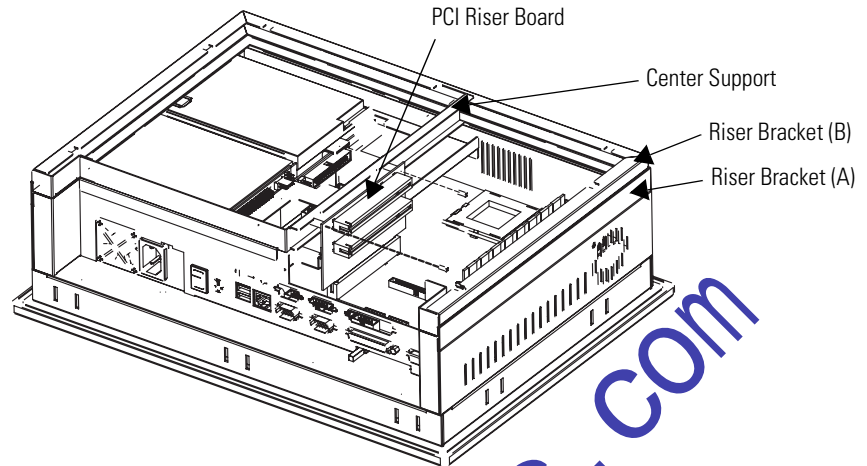

- The slot cover bracket attaches to the chassis with or without PCI cards.
- If installing PCI cards at the time, follow steps 9a - c.
- If not installing PCI cards, attach the slot cover bracket to the chassis as shown in step 9c.
 - a. Attach PCI cards to the slot cover bracket.

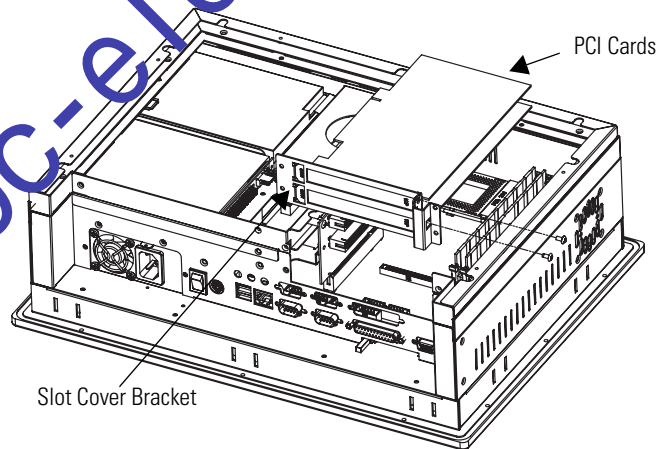

b. Connect PCI cards to the riser board.

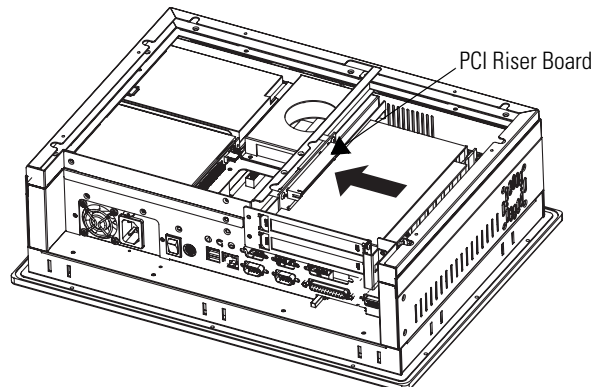

- c. Fasten the slot cover bracket to the chassis by using four, M3x6 panhead screws.

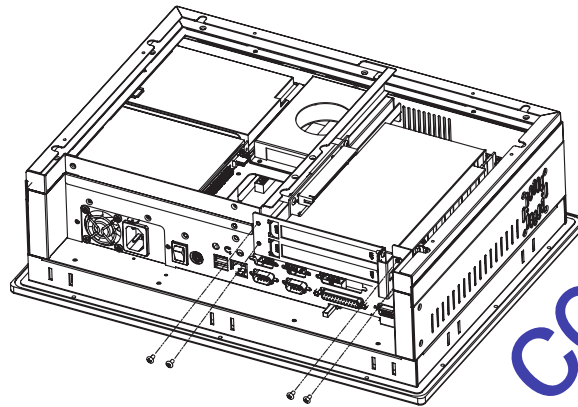

- 9. If installing the expansion kit on a Series A computer, you may discard the replacement air duct and proceed to step 10. If installing the expansion kit on a Series B computer, you must replace the air duct that provides cooling air to the processor.
 - a. Remove the existing air duct from the back cover of the chassis by removing the three screws.
 - b. Attach the replacement air duct to the back cover of the chassis by using the same three screws.
 - c. Set the opening of the duct to its full-open position, if possible.

If the installed PCI cards interfere with the fully-opened duct, then adjust the duct to a lesser opened position to eliminate the interference.

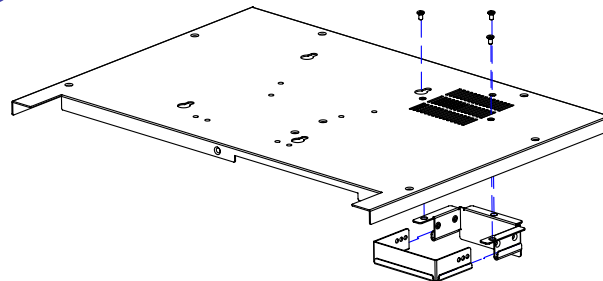

10. Reinstall the back cover over the chassis by using the screws from step 2.

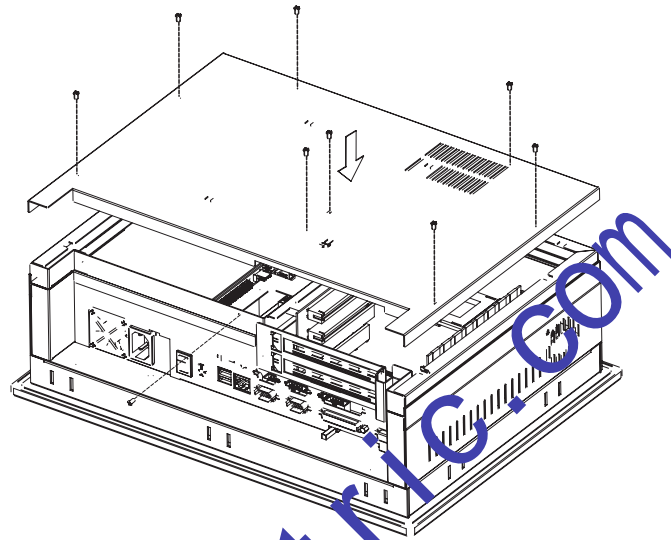

Remove an Add-in Card

Follow these steps to remove an add-in card.

1. Disconnect power from the computer.
2. Remove the back cover.
3. Remove the two screws securing the slot cover bracket to the chassis.
4. Remove the two screws at the top of the PCI riser board.
5. As a single unit, remove the PCI riser board, add-in card, and slot cover bracket from the PCI slot on the CPU board.
6. Remove the screw securing the slot cover bracket to the add-in card.
7. Pull the add-in card free of the slot on the PCI riser board.

Store the card in an anti-static wrapper.

8. Install a slot cover over the open slot on the slot cover bracket and secure with a screw from step 6.
9. Press the PCI riser board into the PCI slot on the CPU board.
10. Replace the two screws at the top of the PCI riser board from step 4.
11. Secure the slot cover bracket to the chassis with two screws from step 3.
12. Reinstall the back cover.

Replace the Floppy Drive (1500P and 1700P)

Follow these precautions when working with the floppy drive.

- Do not touch internal components unnecessarily.
- Always handle the floppy drive by its metal frame.
- Store the floppy drive in an anti-static bag when it is not installed.
- Never disconnect or install a floppy drive with the power on.

ATTENTION

Failure to follow proper safety precautions could result in severe electrical shock and/or damage to the computer.

ATTENTION

Mechanical shock will damage a floppy drive. Do not drop or bump the drive.

Remove the Floppy Disk Drive

Follow these steps to remove the floppy disk drive.

1. Disconnect power from the computer.
2. Remove the back cover.
3. Remove the hard drive.

Do not disconnect the HDD cables.

IMPORTANT

Note the location and orientation of all cables before you remove the existing power supply and cabling, so that you can reattach them correctly.

4. Remove the screw(s) that fasten the floppy drive bracket to the chassis.

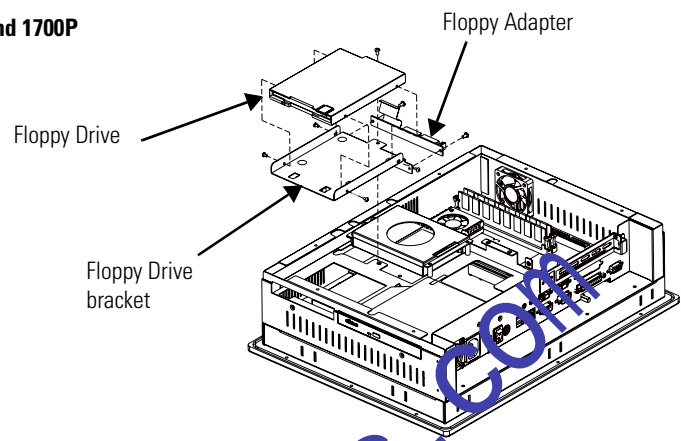
1500P and 1700P

5. Slide the floppy drive and bracket and lift the floppy drive out door-first.
6. Disconnect the flat cable at the floppy drive.
7. Remove the four screws securing the floppy drive to the bracket.
8. Remove the floppy drive.

Install the Floppy Disk Drive

Follow these steps to install the floppy disk drive.

1. Fasten the floppy disk drive to the floppy disk drive bracket with four screws.
2. Connect the flat cable to the floppy disk drive.
3. Insert the floppy disk drive and bracket into the chassis adapter-end first and slide it into position within the chassis.
4. Fasten the floppy disk drive and bracket to the chassis with the bracket screw.
5. Apply glue to prevent separation.
6. Reinstall the hard disk drive.
7. Reinstall the back cover.

Replace the Floppy or Optical Disc Drive (1200P)

Follow these precautions when working with the floppy or optical disc drive.

- Do not touch internal components unnecessarily.
- Always handle the drive by its metal frame.
- Store the drive in an anti-static bag when it is not installed.
- Never disconnect or install a drive with the power on.

ATTENTION

Failure to follow proper safety precautions could result in severe electrical shock and/or damage to the computer.



ATTENTION

Mechanical shock can damage an optical disk drive. Do not drop or bump the drive.



sales@roc-electric.com

Remove the Drive

Follow these steps to remove the drive.

1. Disconnect power from the computer.
2. Carefully separate the display head from the back chassis by removing the 12 perimeter screws.

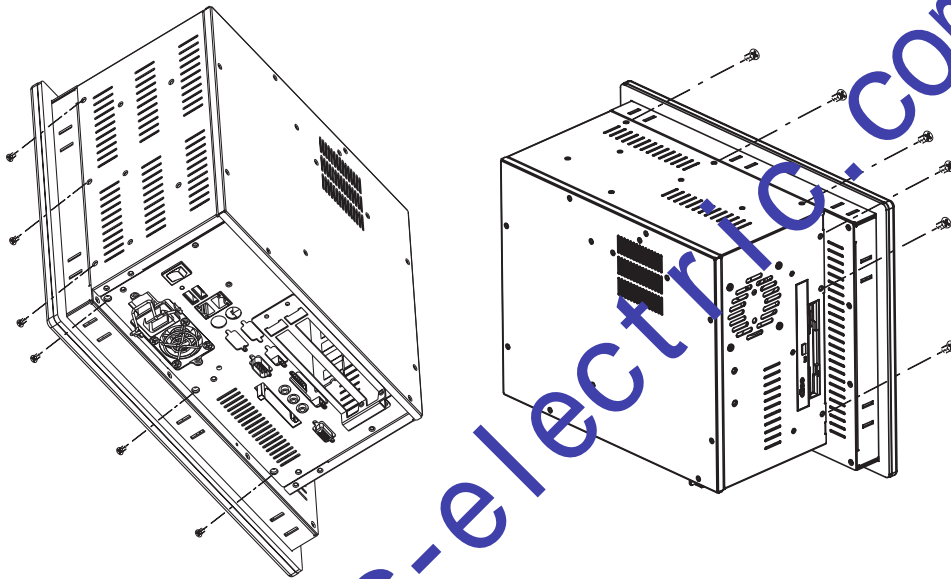

3. Disconnect cables between the display and back chassis as necessary and set the back chassis aside.
4. Remove the floppy or optical disc drive bay by removing the four screws holding the bracket to the inner shelf.
5. Carefully pull out the drive bay assembly.
6. Disconnect the data, power and audio cables from the assembly.

IMPORTANT

Note the location and orientation of all cables before you remove the existing power supply and cabling, so that you can reattach them correctly.

7. For either floppy or optical disc drive removal; disconnect and remove the drive adapter board from the drive.

Be careful with the delicate ribbon cable on the floppy disk drive.

8. Remove the screws securing the drive to the bay and carefully pull out the drive.

1200P

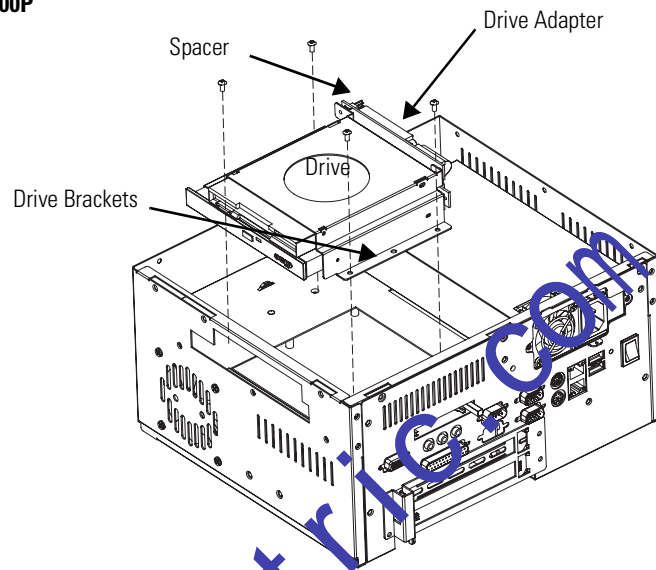

Install the Drive

Follow these steps to install the drive.

1. Fasten the drive to the bay.
2. Connect the drive adapter board to the drive.

Use care with the delicate ribbon cable on the floppy disk drive.

3. Connect the data, power, and audio cables to the drive bay assembly.
4. Carefully replace the drive bay assembly.
5. Fasten the drive bay bracket to the inner shelf with four screws.
6. Connect the cables between the display and back chassis as necessary.
7. Carefully reattach the display head to the back chassis using the 12 perimeter screws.

Replace the Optical Disc Drive (1500P and 1700P)

Follow these precautions when working with the floppy or optical disk drive.

- Do not touch internal components unnecessarily.
- Always handle the drive by its metal frame.
- Store the drive in an anti-static bag when it is not installed.
- Never disconnect or install a drive with the power on.

ATTENTION

Failure to follow proper safety precautions could result in severe electrical shock and/or damage to the computer.

ATTENTION

Mechanical shock can damage an optical disc drive. Do not drop or bump the drive.

Remove the Drive

Follow these steps to remove the drive.

1. Disconnect power from the computer.
2. Remove the back cover.
3. Disconnect the power supply, audio cable, and ribbon cable from the adapter printed circuit board.

IMPORTANT

Note the location and orientation of all cables before you remove the existing power supply and cabling, so that you can reattach them correctly.

4. Remove the two screws that fasten the drive assembly to the chassis.
5. Lift the drive assembly out of the chassis.
6. Remove the four screws that fasten the drive brackets to the drive and remove the brackets from the drive.

7. Remove the two screws and spacers that fasten the adapter to the drive and remove the adapter from the drive.

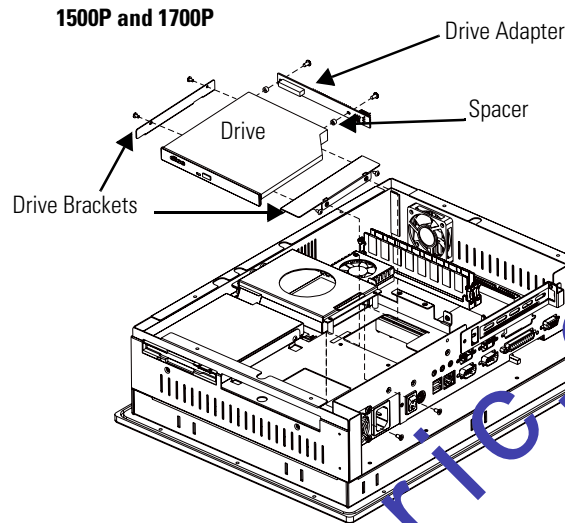

Install the Drive

Follow these steps to install the drive.

1. Fasten the drive to the drive brackets with four screws.
2. Fasten the drive to the drive adapter with two screws and spacers.
3. Gently slide the assembly back into the chassis.
4. Fasten the drive assembly to the chassis with three screws.
5. Connect the power supply, audio cable, and ribbon cables to the drive.
6. Apply glue to ribbon cable and audio cable to avoid separation.
7. Reinstall the back cover.

Add or Remove the Memory Module

The CPU board in the computer has two sockets. Each socket supports a Dual In-Line Memory Module (DIMM).

For a current list of memory modules available for your computer, refer to the Rockwell Automation Allen-Bradley website <http://www.ab.com/industrialcomputers>.

TIP

It is recommended that you use only qualified Allen-Bradley parts.

Guidelines for Replacing Memory

When adding memory to the CPU board, follow these guidelines.

- Always handle the memory cards by the ends not by the memory module contacts.
- Store memory in a sealed anti-static bag when it is not installed.
- Never install or remove memory with the power turned on.

ATTENTION

Failure to follow proper safety precautions could result in severe electrical shock and/or damage to the computer.

**ATTENTION**

Electrostatic Discharge (ESD) can damage the computer and components. Make sure you work in a static-safe environment and wear a grounding strap whenever handling circuit boards, power supply, memory modules or other internal components.



sales@roc-electric.com

System Troubleshooting

Chapter Objectives

This chapter describes the most common operating problems, the probable causes, and recommended corrective actions. It includes:

- Hardware diagnostics
- Troubleshooting procedures
- Troubleshooting checklists

Hardware Diagnostics

The computer monitors:

- Voltage ranges
- Temperature requirements
- Chassis fan speed

Perform this procedure to determine which of these thresholds has been exceeded.

1. Shut down the computer by using the appropriate method for your operating system.
2. Apply power to the computer.
3. Press and hold the Delete (DEL) key to enter BIOS Setup.

The BIOS Setup Menu appears.

4. Press the down arrow key to select the PC Health Status menu for series A or Hardware Monitor Setup menu for series B & C.

Troubleshooting Procedure

Follow this procedure to identify and isolate a problem.

1. Shut down the computer's operating system using the appropriate method for your operating system.
2. Disconnect the power to the computer.
3. Disconnect peripheral devices such as a printer or external drive.
4. Connect the keyboard and mouse, if used.
5. Check the video connections if using an external monitor.
6. If the system normally boots from the hard drive, make sure a disk is not in the floppy drive.
7. Connect power to the computer.

On powerup, monitor the Power On Self Test (POST). One of three events will occur.

- The computer completes the bootup process.
- An error message displays to indicate a non-fatal fault. You may have to acknowledge the message before the startup process continues.
- The bootup process terminates if a fatal error occurs.

8. If the system boots up, isolate the problem by connecting peripheral devices one at a time until the problem occurs.

If the problem is with a specific software package, or driver, reinstall the software.

9. If the problem is not related specifically to a software installation or peripheral device, refer to the troubleshooting checklists.

Troubleshooting Checklists Use the following checklists to test or verify items.

Problems During Start-up

- Are all connections secure?
- Are the device drivers installed?
- Are the jumpers on any add-in boards correctly positioned?
- Is the hard drive formatted and recognized correctly in the BIOS?
- Is the RAM memory properly installed? You may want to reinstall it to ensure a good connection.
- Is the IDE cable from the hard drive properly connected? You may want to see if the system will boot from a floppy disk.
- Is BIOS properly configured? Select 'Load Optimal Default' in the CMOS setup procedure. This will restore the BIOS settings to the original factory settings.

Problems After Start-up

- If you are running a software package, reinstall the software.
- If the problem is intermittent, you may have a loose connection. Check all connections including any PCI cards. Check that the memory module (DIMM) is fully installed.
- Does your system have a computer virus? Run anti-virus software.
- Try clearing CMOS by removing and reinstalling the battery (on backplane) and running BIOS Setup.
- Although the computer has a regulated and protected power supply, a transient voltage in the power line or peripheral cable may cause a flickering display, unexpected reboots, or a locked up system. If so, exit the application and start over.
- Is the IDE cable from the hard drive properly connected? You may want to see if the system will boot from a floppy drive.
- Is the system overheating? Verify that all the fans (CPU, Chassis, power supply) are working.
- Verify that the ambient air temperature is <50 °C (122 °F).
- Check for proper clearance around the computer to verify adequate air flow.

Problems Running the New Software

- Does the software have a hardware requirement that is not present?
- Are you using an authorized copy of the software? Some copies of software will not work without proper activation.
- Did the software install correctly? Reinstall the software.
- Are you following the software's instructions? Refer to the software vendor's user manual.
- If the new software installed system software (DLL files) or device drivers, reapply the current Service Pack (release) of the operating system. Refer to Chapter 3 on Operation.

Problems with the Add-in Card

- Is the board installed and configured correctly? Recheck jumper and other configuration settings.
- Are any cables incorrectly installed?

Problems with the Display

- Are the display contrast and brightness controls properly adjusted? Refer to the operating system containing the video driver for setup functions.
- Is the monitor compatible with the selected video mode? Try setting to the native resolution. See Appendix A for Specifications.

Problems with the Display on an External Monitor

Series A

You can use an external monitor for a temporary connection or for diagnostics. Using an external monitor for normal operation may result in problems such as characters not displaying.

Series B

While the external display is configurable after Windows starts, it is best to have the display connected and turned on when the computer boots up.

Maintenance

Chapter Objectives

This chapter provides information on how to:

- clean the display.
- replace the battery.
- dispose of the backlight assembly.
- ship or transport the computer.

Clean the Display

ATTENTION

Use of abrasive cleansers or solvents may damage the display window. Do not scrub or use brushes.

Follow these steps to clean the display.

1. Disconnect power from the computer at the power source.
2. Using a clean sponge or a soft cloth, clean the display with a mild soap or detergent.
3. Dry the display with a chamois or moist cellulose sponge to avoid water spots.

ATTENTION

If the computer has a touchscreen, be aware that it is possible for screen objects to activate during equipment wash-downs if the computer is turned on.

Remove Paint and Grease

Follow these steps to remove paint and grease.

1. Remove fresh paint splashes and grease before drying by rubbing lightly with isopropyl alcohol.
2. Perform a final wash with mild soap or detergent solution.
3. Rinse with clean water.

ATTENTION



Make sure the isopropyl alcohol does not come in contact with the equipment labels. Alcohol may cause the label printing to smear.

Replace the Battery

The computer contains a lithium battery to maintain CMOS settings and the real-time clock. The battery is in a battery holder on the computer's CPU board. Replace this battery as needed with a Panasonic battery, part number CR2032, or equivalent.

WARNING



To avoid the danger of explosion, only replace the battery with part number CR2032 or a recommended equivalent. Dispose of used batteries according to the manufacturer's instructions.

The battery life depends on the amount of on-time (time computer is powered on) per week. The table lists the estimated life of the battery.

On-time	Expected Battery Life
0 hours/week	4 years
40 hours/week	5.5 years
80 hours/week	7 years

Backlight Assembly Disposal

ATTENTION

The backlight assembly in this unit contains mercury. At the end of its life, this equipment should be collected separately from any unsorted municipal waste.

Ship or Transport the Product

If you need to ship the product via common carrier or otherwise transport it to another location, you must first uninstall the product and place it in its original packing material.

ATTENTION

Do not ship or transport the product when it is installed in a machine, panel or rack. Doing so may cause damage to the product. You must uninstall the product and place in its original packing material before shipping. Rockwell Automation is not responsible for damage incurred to a product that is shipped or transported while installed in a machine, panel or rack.

Sales@roc-electric.com

sales@roc-electric.com

Specifications

Display	
Type	Active Matrix Color TFT
Touchscreen (optional)	Resistive antiglare
Display size 1200P 1500P 1700P	12.1 in. 15 in. 17 in.
Display area (WxH) 1200P 1500P 1700P	246 x 185 mm (9.7 x 7.3 in.) 305 x 229 mm (12 x 9 in.) 338 x 270 mm (13.3 x 10.6 in.)
Resolution, native 1200P 1500P 1700P	800 x 600, 256K colors 1024 x 768, 256K colors 1280 x 1024, 16.7M colors
Response time	15 ms (typical)
Mechanical	
Weight 1200P 1500P 1700P	9.2 kg (21 lb) 10 kg (23 lb) 12.6 kg (28 lb)
Dimensions, overall (HxWxD) 1200P 1500P 1700P	279 x 349 x 176 mm (10.99 x 13.75 x 6.93 in.) 309 x 410 x 109 mm (12.17 x 16.14 x 4.29 in.) 356 x 452 x 110 mm (14.02 x 17.80 x 4.32 in.)
Cutout dimensions (HxW) 1200P 1500P 1700P	254 x 324 mm (10.00 x 12.76 in.) 285 x 386.6 mm (11.24 x 15.22 in.) 329.5 x 424 mm (12.97 x 16.69 in.)
Environmental	
Temperature, operating	0...50 °C (32...122 °F)
Temperature, storage	-20...60 °C (-4...140 °F)
Relative humidity	10...90% without condensation
Shock, operating	15 g (1/2 sine, 11ms) ⁽¹⁾⁽²⁾
Shock, nonoperating	30 g (1/2 sine, 11 ms) ⁽¹⁾
Vibration, operating Computers without solid state drive Computers with solid state drive	1.0 g peak (10...500 Hz) ⁽¹⁾⁽²⁾ 1.5 g peak (10...500 Hz) ⁽¹⁾
Vibration, non-operating	2.0 g peak (10...500 Hz) ⁽¹⁾
Enclosure ratings	NEMA Type 1, 12, 4, IP66 NEMA Type 4X - stainless steel units only

⁽¹⁾ Applies to panel mounted computers only.

⁽²⁾ The floppy disk drive and optical disc drive are considered maintenance devices. You should not operate computers with these devices in environments with the shock and vibration levels listed.

Electrical	
Input voltage, ac	90...264V AC autoranging
Line frequency	47...63 Hz
Ground leakage	1.0 uA max. at 1.5KV dc
Power consumption, AC 1200P, 1500P, 1700P 1200P (6181P-2 non-display)	150 VA (1.5 A @ 100V rms, 0.63A @ 240V rms) 140 VA (1.4A @ 100V rms, 0.58A @ 240V rms)
Input voltage, dc 1200P and 1200P (6181P-2 non-display)	18...32V dc
Power consumption, dc 1200P 1200P (6181P-2 non-display)	150 W 140 W
Certifications⁽¹⁾	
c-UL-us	UL 60950 Recognized Component, C-UL 950 Recognized Component, or UL/c-UL Listed when marked
CE	marked for all applicable directives LVD (73/23/EEC) EMC (89/336/EEC)
C-Tick	Australian Radiocommunications Act

⁽¹⁾ See <http://ab.com> for declarations of conformity, certificates, and other certification details.

sales@roc-electronic.com

Use the Touchscreen

Computers with the touchscreen option are shipped with the touchscreen and touchscreen controller installed and connected.

Touchscreen Serial Port Usage

The optional touchscreen controller connects internally to the COM3 serial port. The touchscreen is factory configured with the proper COM3 and touchscreen driver settings, so no user configuration is required.

Driver Software

The touchscreen driver is already loaded on the computer. The driver software is also on the accessory CD.

TIP

If it becomes necessary to reinstall the touchscreen driver, the touchscreen utility will automatically detect the serial port used by the touchscreen controller.

For Additional Information

For more information on setting up or operating a touchscreen or for future driver upgrades, refer to <http://www.ab.com>.

Resistive Touchscreen Technology

Resistive touchscreens are activated when you apply pressure to the touchscreen with your finger. You can operate a resistive touchscreen while wearing gloves.

ATTENTION

Do not use sharp instruments to activate the touchscreen. Scratching the surface of the touchscreen could damage the unit.

Calibrate the Touchscreen

The touchscreen supplied with the computer is factory installed and calibrated.

Follow these steps to recalibrate the touchscreen.

1. Run the touchscreen configuration utility through the PROGRAMS menu of the operating system.
2. Start the calibration routine offered within the utility.
3. Follow the calibration instructions given on the computer screen.

Sales@roc-electric.com

Upgrade to a New BIOS

Introduction

If a new BIOS is released to enhance the performance of your computer, or to correct a defect, you can download the BIOS and update your computer. Download the BIOS from the Rockwell Automation Allen-Bradley website at <http://www.ab.com>.

BIOS Update Procedure

Follow these steps to update the BIOS.

1. Download the BIOS from <http://www.ab.com/industrialcomputers>.
Locate BIOS under Support Services>Drivers.
2. Load a blank disk in the floppy drive of your computer.
3. Launch the BIOS copy application by double-clicking on the executable file that you downloaded in the previous step.
The application will copy the BIOS loader to the disk.
4. Boot the computer by using the floppy disk created in the previous step.
5. Follow the directions that display on the computer screen to properly update the BIOS.

sales@roc-electric.com

Solid State Drive

Introduction

A reliable means of data storage is a concern in industrial applications with harsh requirements. Standard rotating media with its spinning platters and head arms (with temperature limitations) present obstacles to the reliable storage of data.

Solid state drives (SSD) are a direct replacement for rotating hard drives on the IDE bus. They are drop-in replacements for their hard drive counterparts.

Solid state drives offer improvements over the standard hard drive.

- Improved thermal performance
- Higher levels of shock/vibration
- Less power required
- Longer data retention
- No moving parts

The rotating hard drive is susceptible to shock and vibration. This weakness becomes more apparent as the temperature increases. Although the solid state drive offer improvements in these areas, you must consider limitations of other key components within your system before choosing to replace hard drives.

The decrease in the cost per megabyte of memory in flash drives is making the solid state drive a viable alternative, especially in harsh industrial environments.

Installation

Use caution when installing or handling a solid state drive. Even though the solid state drive is typically designed with a case around the PCB assembly, you must handle the drive with care to prevent possible electrostatic discharge (ESD) damage.

Follow these guidelines when installing or handling a solid state drive.

- Do not touch the exposed connector; handle by the case.
- Ground yourself whenever possible before handling the solid state drive.
- Leave the product in its protective ESD bag until the time of installation.

- The solid state drive installs on the computer's IDE bus via the IDE ribbon cable. Pay close attention to connector alignment. Careless assembly can bend a pin or misalign the connectors, resulting in hardware damage.

Configuration

The solid state drive is configured for a single drive system, or as a master in a multiple drive system. The diagram indicates the various operating configurations.

IMPORTANT

You must power off the drive whenever making a mode change.

IDE Drive Connector Interface

The solid state drive uses a 44-pin (2 mm pitch) connector to attach to the IDE bus.

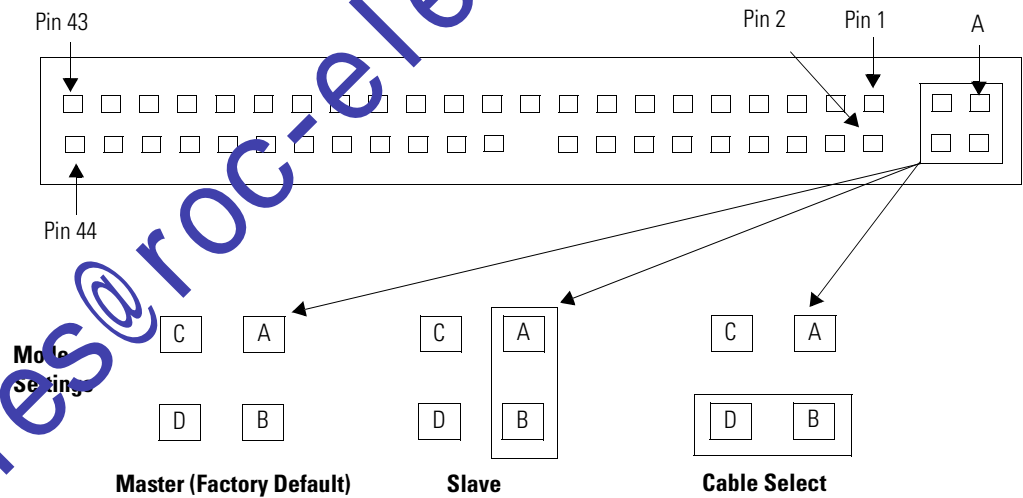

Operation

The solid state drive appears to the system host as a standard rotating hard drive when powered up. The system host identifies the solid state drive during powerup and sets the IDE bus speed to reflect the drives capability.

- DMA-2 (multiword) or
- PIO-4

In DMA-2 or PIO-4, the maximum IDE bus speed is 16.7 M.

The controller on the solid state drive uses an error correcting code (ECC) and cyclic redundancy check (CRC) to check for data errors. The ECC code consists of six bytes per 512 bytes (one sector) and is stored with the data in flash memory.

Data correction algorithms can prevent data corruption on the drive. However, they cannot prevent operating system (OS)/file type errors when the OS breaks large files into smaller (multiple) file transfers. This results in the host receiving only part of the transfer.

IMPORTANT

Always protect your system against unexpected power interruptions.

Always shutdown your windows application using the Start menu on the desktop. Whenever possible, use an uninterruptible power source (UPS) or other power conditioning device to perform a proper shutdown during unexpected power interruptions.

Life Expectancy

The limitation of the solid state drive is the finite amount of writes to a specific memory location. The life expectancy of a solid state drive varies depending on:

- how often an application writes data to the drive.
- the size of the file written to the drive.
- the amount of available space on the drive that can be used by the drive's controller to write data.
- the write/erase cycle limitation the manufacturer specifies.

On the flash drive, the smallest space that can be written to is a sector, which is 512 bytes. However, the smallest space that can be erased is a block of memory. Unlike magnetic media, an erase cycle is required for flash memory before a write can be made. The actual block size varies depending on the overall capacity of the flash drive, for example, 63 sectors, or 32 K on a 4 GB drive.

Wear leveling algorithms in flash memory drives offer an advantage to the overall throughput of the memory and the life expectancy of the drive. Wear leveling evenly distributes data that is written to memory across all free space on the drive. As one block of memory is written and filled, another is made available for the next data transfer. This block mapping occurs across all the free space and then starts again at the initial block. At the same time, the drive’s controller erases blocks previously used allowing memory to be available for updates without delaying the write requests from the host CPU.

When a memory cell fails within a specific sector, the entire block where the sector resides is marked as bad and removed from use. A new block from the pool of spares replaces the bad block. The amount of spare blocks within the pool is determined by the size of the drive memory. The size of the pool typically falls in the range of 1 to 1.5% of the total drive memory space and is set when initially formatted.

Typical Solid State Drive

Drive	SimpleTech 4 GB
Sector	512 bytes
Sectors	8,388,608
Blocks	32,768 (1 block = 131,072 bytes)
Zone	512 blocks (wear level boundary)
Write Cycle Limit	2 million
Free Space	4 GB (OS image + installed applications)
1 Year	8,760 hours
Seconds/Year	31,536,000

Application Example One

An application updates a 100K data file every second on the 4 GB SimpleTech drive that is approximately half full with the OS image and application software.

Use this formula to calculate expected life.

$$(\text{Flashblocks} \times \text{Write Cycle limit} \times \text{Drive Freespace}) / [(1 \text{ block/sec}) \times (31,536,000\text{sec/yr})]$$

$$(32,768 \times 2,000,000 \times .5) / [(1 \text{ block/sec}) \times (31,536,000 \text{ sec/yr})] = 1039 \text{ years}$$

Application Example Two

The OS is updating its FAT table and root directory twice a second. This update requires one block of memory (128 K). Every write regardless of location writes to a single block. In this case, wear leveling is limited to 1 zone (512 blocks).

Use this formula to calculate expected life:

$$(\text{Flashblocks} \times \text{Write cycle limit}) / [(2 \text{ block/sec}) \times 31,536,000/\text{yr}]$$

$$(512 \times 2,000,000) / [(2 \text{ block/sec}) \times 31,536,000 \text{ sec/yr}] = 16.2 \text{ yrs}$$

Normally in a Windows operating environment virtual memory is used, also known as a 'swap file' or 'page file'. The OS may read from and write to this file often in a short period of time. Although the space used could be small, an entire block of memory is required. On systems using solid state memory, it is recommended that this feature be turned off.

Maintenance

Under normal operating conditions, scheduled maintenance is not required. The integrity of data stored on a solid state drive is good for up to ten years.

sales@roc-electric.com

A

accessories 10
add-in cards, installing and removing 32

B

back cover, removal 32
battery replacement 54
boot the system 30

C

calibrating touchscreen 60
cover removal 32
cutout dimensions 19

D

diagnostics, hardware 49
display, cleaning 53
driver installation 30

F

features (top, side, bottom view) 12
floppy drive
 1200P 42
 1500P and 1700P 40

H

hardware diagnostics 49

I

installation 15
 clearances 18
 connecting AC power 26
 connecting DC power 27
 connecting keyboard 20
 connecting pointing device 25
 considerations 17
 floppy drive (1200P) 42
 floppy drive (1500P and 1700P) 40
 mounting cutout 23
 mounting dimensions 23
 mounting procedure 19
 optical disk drive (1200P) 42
 optical disk drive (1500P and 1700P) 45
 panel mounting 19
 panel mounting guidelines 19
 required tools 19

K

keyboard, connecting 25

M

maintenance
 battery 54
 cleaning display 53
mounting dimensions 23
multilingual user interface 11

N

network connection 26

O

operating guidelines 29
operator access 29
optical disk drive
 1200P 42
 1500P and 1700P 45

P

panel mounting instructions 20
pointing device, connecting 25
power
 connect DC 27
power, connecting AC 26
power, connecting DC 27

R

replacement parts 10
reset 30

S

safety precautions 31
ship product 55
solid state drive
 advantages 63
 configuration 64
 IDE Drive Connector Interface 64
 installation 63
 life expectancy 65
 life expectancy examples 66
 operation 65
specifications
 agency approvals 58
 display 57
 electrical 58

- environmental 57
- mechanical 57
- system reset** 30

T

- touchscreen**
 - calibrating 60
 - driver software 59
 - serial port 59
 - type 59
- troubleshooting** 49
 - characters not displaying 52

- check lists 51
- distorted or incorrect characters 52
- problem after boot-up 51
- problem during boot-up 51
- problem running software 52
- problem with add-in board 52
- problem with add-in card 52
- procedure 50

U

- USB, installing or using** 30

sales@roc-electric.com

sales@roc-electric.com

Rockwell Automation Support

Rockwell Automation provides technical information on the Web to assist you in using its products. At <http://support.rockwellautomation.com>, you can find technical manuals, a knowledge base of FAQs, technical and application notes, sample code and links to software service packs, and a MySupport feature that you can customize to make the best use of these tools.

For an additional level of technical phone support for installation, configuration, and troubleshooting, we offer TechConnect support programs. For more information, contact your local distributor or Rockwell Automation representative, or visit <http://support.rockwellautomation.com>.

Installation Assistance

If you experience a problem within the first 24 hours of installation, please review the information that's contained in this manual. You can also contact a special Customer Support number for initial help in getting your product up and running.

United States	1.440.646.3434 Monday – Friday, 9am – 5pm EST
Outside United States	Please contact your local Rockwell Automation representative for any technical support issues.

New Product Satisfaction Return

Rockwell Automation tests all of its products to ensure that they are fully operational when shipped from the manufacturing facility. However, if your product is not functioning and needs to be returned, follow these procedures.

United States	Contact your distributor. You must provide a Customer Support case number (call the phone number above to obtain one) to your distributor in order to complete the return process.
Outside United States	Please contact your local Rockwell Automation representative for the return procedure.

www.rockwellautomation.com

Power, Control and Information Solutions Headquarters

Americas: Rockwell Automation, 1201 South Second Street, Milwaukee, WI 53204-2496 USA, Tel: (1) 414.382.2000, Fax: (1) 414.382.4444

Europe/Middle East/Africa: Rockwell Automation, Vorstlaan/Boulevard du Souverain 36, 1170 Brussels, Belgium, Tel: (32) 2 663 0600, Fax: (32) 2 663 0640

Asia Pacific: Rockwell Automation, Level 14, Core F, Cyberport 3, 100 Cyberport Road, Hong Kong, Tel: (852) 2887 4788, Fax: (852) 2508 1846

Publication 6181P-UM001G-EN-P - July 2008

Supersedes Publication 6181P-UM001F-EN-P - July 2007

Copyright © 2008 Rockwell Automation, Inc. All rights reserved. Printed in the U.S.A.